



Product Data Sheet Arched Coping

Description:

The arched coping offers a complete finish to any parapet wall. The system utilizes pre-notched lap joints, allowing for fast and secure installation and yielding positive water drainage.

- Fabricated in 5' lengths to fit each arch radius specification; widths are customized to specification.
- Three piece construction using Pittsburgh seam.
- Fabricated to wall width 6" to 40".
- 3" minimum face and back leg size.
- Hemmed drip kick to receive splice cleats.
- Splice cleats spaced 24" o.c.

Contact Mule-Hide to request a color chart, samples and information regarding custom metals and finishes.

Energy Efficiency:

LEED® and ENERGY STAR® compliant; 100% recyclable.

Installation:

1. A wood nailer attached to the top of the parapet wall is required.
2. This nailer should be attached to the wall in accordance with ANSI/SPRI ES-1 3.9.
3. Install the arched coping in accordance with Mule-Hide details.
4. Any deviation from the requirements set forth in the detail drawings must be pre-approved, in writing, by the Mule-Hide Technical Department.

Warranty:

Mule-Hide metal accessories are eligible for warranty coverage when properly installed as part of a Standard or Premium warrantable system. Please visit our Web site or call us for more information.

Technical Services:

Product samples, detail sheets, color chips, and color chart are available for your submittal package. For assistance with questions or submittals, contact your local representative or call Mule-Hide.

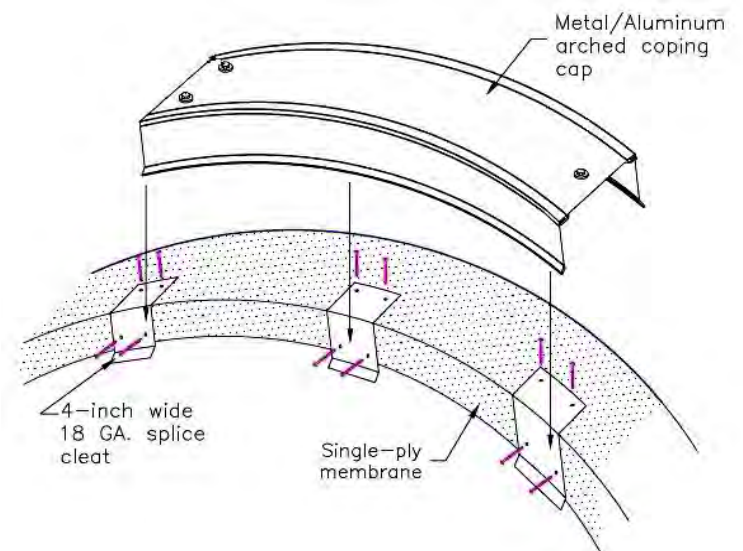
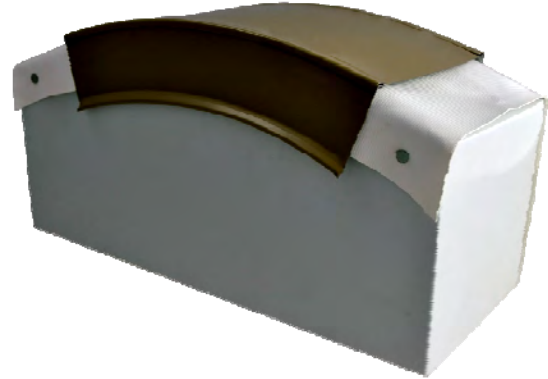

Material	Gauge	Finish
Aluminum	.032	Mill or Kynar®
Stainless Steel	24-gauge	N/A
Bonderized Steel	24-gauge	N/A
Galvalume	24-gauge	N/A