

PRE-HEAT AND PRE-STRETCH TPO
NON-REINFORCED FLASHING
MEMBRANE TO FORM AROUND PIPE
PRIOR TO HOT AIR WELDING IN PLACE

NOTES:

1. THIS DETAIL USED FOR FIELD-FABRICATED PIPE SEAL FOR USE WITH HOT PIPE, 160° F OR HOTTER.
2. TPO NON-REINFORCED FLASHING WRAPPED AROUND PIPE SHALL HAVE MINIMUM 1-1/2" VERTICAL HOT AIR WELD.
3. TEMPERATURE OF METAL SLEEVE MUST NOT EXCEED 160° F.

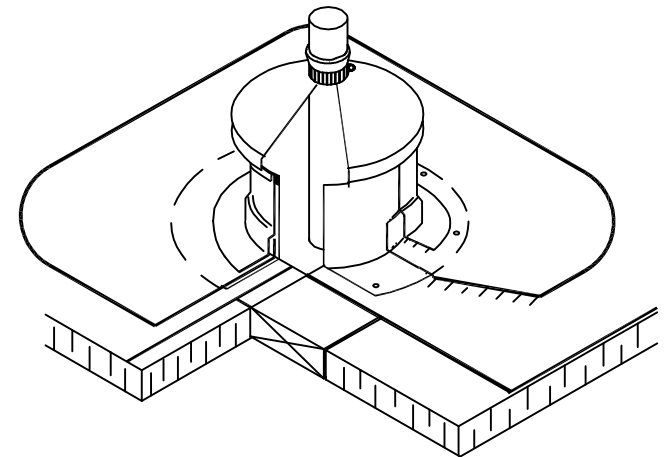

**MULE-HIDE
PRODUCTS CO., INC.**

**HOT PIPE FLASHING
WITH COLD SLEEVE
SYSTEMS:
ALL TPO SYSTEMS**

DETAIL NO.:
MHT-UN-522
REVISION DATE: 10/2013