

# TPO

POCKET GUIDE



*“The name trusted in roofing since 1906”*

# Mule-Hide Products TPO Field Installation Guide Mechanically Fastened and Fully Adhered Systems

March 2017

<b><u>Heat-Welding Equipment and Guidelines</u></b> .....	<b>Page</b>
Equipment Checklist.....	5
Welding Guidelines .....	6

## **Mechanically Attached Sheet Layout**

Sheet Fastening Guidelines.....	18
Perimeter Enhancement Requirements.....	20
Field Membrane Layout (MHT-MA-101A).....	21
Field Membrane Layout – RUSS (MHT-MA-101B).....	22
Perimeter Attachment – Option 1 (MHT-MA-102A).....	23
Perimeter Attachment – Option 2 (MHT-MA-102B).....	24
Buildings with Large Wall Openings (MHT-MA-103A) .....	25
Buildings with Overhangs (MHT-MA-103B) .....	26
Roof Perimeter Calculation (MHT-UN-108A).....	27
Roof Perimeter Calculation (MHT-UN-108B).....	28
FM Perimeter/Corner – Option A (MHT-FM-308A).....	29
FM Perimeter/Corner – Option B (MHT-FM-308B).....	30

## **Mechanically Fastened Lap Details**

Seam Attachment (MHT-MA-104A) .....	31
Seam Plate Placement (MHT-MA-104B).....	32

## **Membrane Laps**

Field Seam (MHT-FA-104D) .....	33
End Lap (MHT-UN-104C).....	34
End Laps – Fleece & Self Adhering (MHT-FA-104E).....	35
T-Joint Detail 045" (MHT-UN-105A).....	36
T-Joint Cover 060" or Thicker (MHT-UN-105B) .....	37
Field/Wall Seam Transition Patch (MHT-UN-105C).....	38

## **Roof Edge Treatment**

Drip Edge – TPO Coated Metal (MHT-FA-106A).....	39
Drip Edge – TPO PS Cover Strip (MHT-UN-106B).....	40
Drip Edge – EPDM Cover Strip (MHT-UN-106C) .....	41
Tapered Edge/Gravel Stop (MHT-UN-201).....	42
Snap-on Fascia w/spring Clips (MHT-UN-202A).....	43
Snap-on Fascia (MHT-UN-202B).....	44
Anchor-Tite Fascia System (MHT-UN-204).....	45
Fascia/Drip Edge System (MHT-UN-205) .....	46
All-Purpose Bar – Edge Termination (MHT-UN-206).....	47
Gravel Stop – TPO Coated Metal (MHT-UN-211) .....	48
Gravel Stop – TPO Coated Metal (MHT-UN-212) .....	49
Gravel Stop Joint Detail – TPO Metal (MHT-UN-213) .....	50
Thru-wall Scupper – TPO Metal (MHT-UN-220A).....	51
Thru-wall Scupper – TPO Metal (MHT-UN-220B).....	52

Thru-wall Scupper – New Metal (MHT-UN-220C).....	53
Thru-wall Open Scupper – TPO Metal (MHT-UN-221).....	54
Gravel Stop Scupper – TPO Metal (MHT-UN-222).....	55
Gutter Drip Edge – TPO Metal (MHT-UN-232).....	56
Gutter/Termination Bar – Recover (MHT-UN-234).....	57
Edge Termination – All-Purpose Bar (MHT-UN-240).....	58
Membrane Coated Drip Edge (MHT-3120).....	59
T-Edge Metal Edge (MHT-3550).....	60
T-Edge Plus Metal Edge (MHT-3555).....	61
2-Piece Compression Edge (MHT-3110).....	62
1-3/4" Metal Fascia System (MHSM-3500).....	63

## **Parapet**

Parapet Wall Detail – New Coping (MHT-UN-301).....	64
Parapet Wall – Existing Coping (MHT-UN-302).....	65
Insulated Parapet Wall (MHT-UN-303).....	66
Base Attachment w/Plates & Fasteners (MHT-UN-305A).....	67
Base Attachment w/RUSS (MHT-UN-305B).....	68
Counter Flashing Detail (MHT-UN-310).....	69
Base Flashing at Siding (MHT-UN-311).....	70
Wall Flashing w/M-H All-Purpose Bar (MHT-UN-312).....	71
Door Threshold – Wall Flashing (MHT-UN-321).....	72
Base Attachment w/A-P Bar (MHT-UN-330).....	73
Base Attachment – Self Adhering (MHT-FA-305C).....	74
Base Attachment – Fleece (MHT-FA-305D).....	75
Base Attachment – Inverted Fleece (MHT-FA-305E).....	76

## **Expansion Joints**

Expansion Joint Detail (MHT-UN-401).....	77
Expansion Joint – Curb (MHT-UN-402).....	78
Expansion Joint – Wall Detail (MHT-UN-403).....	79
Expansion Joint Detail (MHT-UN-404A).....	80
Expansion Joint Detail (MHT-UN-404B).....	81

## **Curb Flashing**

Curb/Wall Flashing w/A-P Bar (MHT-UN-502).....	82
Curb/Wall Flashing w/Counter Flashing (MHT-UN-502A).....	83
Curb Flashing (MHT-UN-503).....	84
Curb Flashing-Fleece/Self Adhering (MHT-UN-503A).....	85

## **Roof Drains**

Drain Flashing – Tapered Insulation (MHT-UN-510A).....	86
Drain Flashing w/Target (MHT-MA-510B).....	87
Drain Flashing w/Target Panels (MHT-UN-511A).....	88
Drain Flashing w/Target (page 1 of 2) (MHT-UN-511B1).....	89
Drain Flashing w/Target (page 2 of 2) (MHT-UN-511B2).....	90
Retrofit Drain Insert (MHT-UN-512).....	91
Drain Flashing w/Target – Fleece (MHT-FA-510C).....	92
Drain Flashing w/Target – Fleece/SA (MHT-FA-510D).....	93

## **Pipe / Penetration Flashings**

Pre-molded Pipe Boot (MHT-UN-520).....	94
Field Fabricated Pipe w/ Band Clamp (MHT-UN-521A).....	95
Field Fabricated Pipe w/Seam Tape (MHT-UN-521B) .....	96
TPO Split Pipe Boot (MHT-UN-521C) .....	97
Hot Pipe Flashing w/Cold Sleeve (MHT-UN-522).....	98
I-Beam Support Flashing (MHT-UN-523).....	99
Multiple Pipe Penetration (MHT-UN-525) .....	100
Pitch Pan TPO-coated Metal (MHT-UN-526).....	101
TPO Molded Sealant Pocket (MHT-UN-527) .....	102
Square Tubing Wrap (MHT-UN-528) .....	103
Wood Sleeper Detail (MHT-UN-530) .....	104
Fixed Equipment Support (MHT-UN-531) .....	105

## **Valley / Ridge Flashing**

Valley Flashing (MHT-MA-601A).....	106
Valley Flashing – RUSS (MHT-MA-601B) .....	107
Valley Flashing (MHT-FA-601C).....	108
Valley Flashing – RUSS (MHT-FA-601D) .....	109
Ridge Flashing (MHT-MA-602A).....	110
Ridge Flashing (MHT-FA-602B).....	111

## **TPO Tie-Ins**

Tie-in to Solid Deck w/Curb (MHT-UN-609).....	112
Tie-in to Existing BUR/MB Roof (MHT-UN-610A).....	113
Tie-in - Existing BUR (MHT-UN-610B).....	114
Tie-in - Existing EPDM or Hypalon (MHT-UN-610C) .....	115
Tie-in - Shingle Roof (MHT-UN-611A).....	116
Tie-in - Shingle Roof – RUSS (MHT-UN-611B) .....	117

## **Miscellaneous**

Sleeper Detail (MHT-UN-620).....	118
Lightning Cable Strap (MHT-UN-621) .....	119
Lightning Rod Base (MHT-UN-622A) .....	120
Lightning Rod Detail (MHT-UN-622B) .....	122
Lightning Rod Wall Support (MHT-UN-623) .....	122
Termination Details (MHT-UN-624).....	123

## **TPO Corner Flashings**

Inside Corner Flashing (MHT-UN-640A) .....	124
Inside Corner Flashing w/RUSS (MHT-UN-640B) .....	125
Field Fabricated Inside Corner (MHT-UN-640C).....	126
Field Fabricated Outside Corner (MHT-UN-641A) .....	127
TPO Universal Corner – Outside (MHT-UN-641B) .....	128

## **Insulation Attachment**

Extruded Polystyrene Insulations (MHT-MA-700).....	129
Insulation Attachment Patterns (MHT-MA-701) .....	130
Mule-Hide – 8 Field Fasteners (MHT-FA-720).....	131

Mule-Hide – 12 Field Fasteners (MHT-FA-721) .....	132
Mule-Hide – 16 Field Fasteners (MHT-FA-722) .....	133
Mule-Hide – 17 Field Fasteners (MHT-FA-723) .....	134
Factory Mutual – 8 Field Fasteners (MHT-FM-724) .....	135
Factory Mutual – 12 Field Fasteners (MHT-FM-725) .....	136
Factory Mutual – 16 Field Fasteners (MHT-FM-726) .....	137
Factory Mutual – 17 Field Fasteners (MHT-FM-727) .....	138
Helix Foam – 4" Bead Spacing (MHHA-UA-4) .....	139
Helix Foam – 6" Bead Spacing (MHHA-UA-6) .....	140
Helix Foam – 12" Bead Spacing (MHHA-UN-12) .....	141

## **TPO Metal Retrofit**

Drip Edge – TPO Coated Metal (MMRT-101) .....	142
Drip Edge – TPO Cover Strip (MMRT-102) .....	143
Drip Edge w/ Gutter – TPO Metal (MMRT-103) .....	144
Field Attachment w/ 10" RUSS (MMRT-110) .....	145
Field Attachment into Purlins (MMRT-111) .....	146
Ridge Attachment w/ 10" RUSS (MMRT-180) .....	147
Sheet Layout <100 Mph Wind Zone (MMRT-300) .....	148
Sheet Perpendicular to Slope <100 Mph Wind Zone (MMRT-301) .....	149
Sheet Parallel to Slope <100 Mph Wind Zone (MMRT-302) .....	150
Sheet Layout <120 Mph Wind Zone (MMRT-303) .....	151
Sheet Perpendicular to Slope <120 Mph Wind Zone (MMRT-304) .....	152
Sheet Parallel to Slope <120 Mph Wind Zone (MMRT-305) .....	153
Purlin Attached w/ Narrow Sheets (MMRT-310) .....	154
Purlin Attached w/ Wide Sheets (MMRT-311) .....	155

## Equipment Needed to Install Mule-Hide Heat-Weld Membranes

**Introduction** - This section is intended to serve as a general guideline of the equipment that the contractor may need to successfully install a Mule-Hide Heat-Weld Membrane Roofing System.

**General** - The following list of hand tools should be included for an average crew of 4 - 6:

- One automatic welder
- Asphalt-free extension cord (#10/3 wire, 220 volt) with 220/30 amp male- female twist lock plugs for use with the automatic welder, not to exceed 100 feet in length
- 2 or 3 hand welders with nozzles
- Asphalt-free extension cords (#14/3 wire, 110 volts)
- 3 or 4 rubber hand rollers
- 1 pair of scissors per person
- 3 standard screw guns with disengaging clutch (RPM range of 1800-2500 with adjustable nose piece)
- Tape measures and one 100-foot tape
- 2 or 3 cotter pin extractors for probing seams
- Non-permanent ink pens (water soluble)
- Chalk lines with non permanent chalk (blue chalk)
- 4-inch wide paint brushes
- One-half inch nap paint rollers with solvent-resistant cores and handles
- Clean cotton rags
- Caulking guns
- Push brooms
- Asphalt-free waterproof canvas or other type of waterproof tarp for covering Mule-Hide products and equipment

**Specialized Equipment** - The Mule-Hide Roofing System requires 4 types of specialized equipment:

- Mule-Hide-approved automatic hot air seaming machine
- Mule-Hide-approved hand-held seaming machine
- Generator large enough to provide power to automatic welder and hand gun(s)

**WARNING:** Never touch the metal portion of the fan housing, blower tube or blower nozzle of the automatic welder or hand-held heat guns. They become extremely hot and can cause severe burns.

## **MEMBRANE WELDING**

The Mule-Hide heat-weld membranes can be permanently fused together by the application of super-heated air and pressure. To provide the required heat and pressure, Mule-Hide heat-weld membrane roofing systems specify an automatic welder for making field seams. A hand welder is specified when an automatic welder cannot be used (see next section).

### **Automatic Welder**

General Description: An automatic welder is an electrically powered, self-propelled device that utilizes electrical resistance heating and fan-forced hot air in combination with its own weight (including additional weight mounted on the exterior housing) to fuse the Mule-Hide heat-weld membranes together.

### **Technical Specifications**

The following specifications are for general information. Consult the manual accompanying the equipment for additional details.

- **Electrical requirements:** 220V, 30A (minimum fused), 7500 W (minimum recommended available power), single-phase current. If using a generator, ensure generator is of sufficient size to power all welding tools (hand gun(s), automatic welder) run from generator.
- **Power cord and extensions:** #10, 3-conductor type may be used for distances up to 100 ft.; for longer lengths, consult an electrical contractor. The use of the highest quality electrical cords extend equipment life and improve overall performance.
- **Supplemental weight:** When welding Mule-Hide field membrane, an additional weight is to be fixed on the exterior housing over the wheels of the automatic welder. Most automatic welders have removable external weights.
- **Adjustments:** Tracking alignment, nozzle alignment, forward speed, temperature of heating element and airflow louver (and therefore hot air output).
- **Welding speed:** The speed of the welder must be no faster than necessary to reproduce good hot-air weld and will vary according to environmental conditions. As a general rule, 10 to 12 feet per minute (fpm) is a typical speed in warm summer temperatures; 8 fpm or less is typical in cold weather temperatures.
- **Metal track (if required by welder manufacturer):** Several lengths, 8 foot each of 24-26 gauge galvanized metal for use as a track for the automatic welder. The metal tracks may be necessary to minimize wrinkles during welding.

**NOTE:** Conditions seldom justify running at maximums speed, which usually result in inconsistent seam quality. As ambient temperatures change throughout the day, the operator must determine the optimum operating speed and temperature of the automatic welder. It is good roofing practice to conduct test seaming before welding the field seams. See page 4 for test welding instructions.

## Procedure - Before Connecting to Power

Use the automatic hot-air welder to make all field seams as general practice; the nozzle can be adjusted to weld near-horizontal seams (typical field seams).

Be sure to take the following preliminary steps when using an automatic unit.

1. Supplemental weight. Fix the supplemental weight to the exterior housing over the wheels. This weight will ensure that the proper pressure is applied to the seam being welded.
2. Check hot-air nozzle alignment and adjust if required.
3. Welding and non-welding positions. The hot-air nozzle can be locked into an UPWARD non-welding position, or into its DOWNWARD welding positions. The nozzle and blower assembly can be freely raised from the welding position after the release trigger on the blower housing is pulled and the entire assembly is slid OUTWARD from the machine. In this OUTWARD position, the nozzle and blower assembly escapes the detent that locks it into the DOWN position, and can be rotated to the UP position, where it will lock when the trigger is released. Position the hot-air nozzle so that it is in its DOWNWARD welding position and visually check to ensure that the nozzle will not direct the hot air into the silicone drive wheel or belt. Such misdirected super-heated air can quickly ruin the expensive wheel or belt drive. Any misalignment of the nozzle should be corrected at this time. After ensuring that the nozzle is properly aligned, return the hot-air nozzle to its UPWARD, non-welding position.

Be sure that the blower and transmission power switches are OFF and the blower temperature control and speed control are set to ZERO.

**Checkpoint:** At this point, it is assumed that you are ready to hot-air weld a field seam, and the following requirements have been met:

- A roll of Mule-Hide heat-weld membrane has been attached to the roof deck, and a second roll has been unrolled to provide a 5-1/2-inch overlap for mechanically attached and a 3" overlap for fully adhered over the previously attached edge, per Standard Mule-Hide Specifications.
- The surfaces to be hot-air welded are clean. If these surfaces are dirty, they must be rag-wiped clean with Fantastik® (or similar cleaner), then wiped with a clean rinse rag and thoroughly dried. The seam area should then be wiped with a clean rag dampened with Mule-Hide Membrane Cleaner to ensure removal of any remaining dirt or soap film.
- With the nozzle and blower assembly in the UP position, the automatic welder is positioned so that the silicone pressure wheel or belt is placed at the edge of overlapping sheet and the beveled guide wheel in front is at the edge of the top Mule-Hide sheet.
- Transmission and blower switches are OFF and speed and heat controls are set to ZERO.

**WARNING:** Never touch the metal portion of the fan housing blower tube, or blower nozzle. They become extremely hot and can cause severe burns.



## Procedure - Connecting to Power

With the preliminaries done, you are ready to hot-air weld.

4. Connect the machine to power.
5. Turn the heater/blower power switch ON.
6. Set the temperature switch to the desired setting (1004° F is a good starting point).
7. Allow the machine to warm up (generally around 5 minutes).

**NOTE:** Test seams should be made at least at the start of work each morning and afternoon or any other time there is a noticeable change in temperature. Test seams should be made on use scrap material. After scrap material has cooled, attempt to physically tear apart and examine for consistent 1-1/2 to 2-inch wide fully laminated seams.

8. Prepare to set the machine in motion.
  - If ambient temperature is higher than 60°F, adjust the transmission speed control switch so that the machine will move at about 12 fpm; further adjustment may be required once you are underway, depending on the quality of the seam produced.
  - If ambient temperature is 40-60°F, adjust the machine to move at about 10 fpm; further adjustment may be required, depending on the quality of the seam produced.
  - If ambient temperature is less than 40°F, adjust the machine to move at less than 8 fpm; the best rate will have to be determined based on the quality of the seam produced. As a general rule, the colder the ambient temperature - and, hence, the membrane - the more slowly the automatic welder will have to proceed in order to produce good seams.

**NOTE:** As there are no ideal working conditions and ambient temperatures change throughout the day, the operator must determine the operating speed of the automatic welder.

**CAUTION:** The operator of the welding equipment should be absolutely sure that the machine is positioned properly to begin welding before proceeding to the next step. Remember the guide handle points IN THE DIRECTION THAT THE MACHINE WILL MOVE.

9. Separate the overlapping sheets. Place one hand palm-down on the blower housing, and put your index finger on the release trigger. With your other hand, use a seam probe (or similar tool) to separate the two overlapping Mule-Hide heat-weld membranes so that the nozzle can be slid between them.
10. Insert the blower nozzle between the sheets. Pull the trigger, and position the nozzle between the membrane sheets, locking it in the DOWN welding position. Immediately proceed to the next step to prevent burning the membrane!
11. Start the machine moving. Quickly turn the transmission switch ON.

**NOTE:** Some machines start automatically. The machine will start moving and welding the seam. Mark the start of the seam with a water-soluble marker.

12. Stay on course. As the automatic welder proceeds, keep the small guide wheel at the front of the machine at the edge of the top sheet. Steer the machine from the front to minimize zigzagging, which is likely to result from steering from the rear. If you go off-course, simply get back on course quickly. Seam deficiencies can be repaired later with the hand welder.

**IMPORTANT:** Keep plenty of slack in the power cord. Any drag can pull the machine off course.

13. Adjust to the speed that produces the best weld. The guidelines set in Step 8 provide good starting points. As welding proceeds, some trial-and-error adjustments are required. Generally, adjusting the speed will be the most effective means of "dialing in" the best seam production. When the ambient temperature is very high, it may be necessary to turn the temperature down.

### Rules-of-Thumb for Judging Seam Quality

- The seamed membrane is not discolored, increase speed if membrane discolors (yellow/brown). If ambient temperature is very high and membrane discolors even when speed is at maximum, turn down the temperature control.
  - Bubbling. If welder setup is marginally too hot, the seam surface may exhibit a slight bubbling appearance.
  - Voids and wrinkles. A good seam has no voids or wrinkles and is 2-inches wide with the exposed edge tight. If not, see "Repairing Voids and Wrinkles," and "Repairing Holes in Membranes."
  - Seam strength may be tested when cool. For best results, testing seams 8 hours after hot-air welding is recommended.
14. Completing a welding run. At the end of a run, lock the nozzle in it's UP, non-welding position and turn the transmission switch OFF to stop the machine's movement. NOTE: Some machines stop automatically when the nozzle is taken out of the seam. Mark the end of the seam with a water-soluble marker.
  15. Clean the nozzle frequently. The nozzle should be wire-brushed frequently to remove hot particles of the Mule-Hide heat-weld compound. (Some applicators wire-brush after each welding run.) If not removed, such particles are likely to be deposited by the nozzle, forming brown streaks at the edge of the lap; more than aesthetics is at stake - the presence of such particles in the seam can affect seam integrity.
  16. Cool the welder down. At the completion of a period of welding - for example, on breaks - with the nozzle locked in the UPWARD position, turn the temperature adjustment dial to the lowest setting. The heating element will shut off, but the blower will continue to operate, cooling the heating element. After about five minutes, turn the power switch OFF.

NOTE: Some machines will shut down automatically after pushing only one button.

## Precautions

As with any high-power electrical equipment used outdoors, use accepted practice and common sense to avoid injury. Some suggestions:

- Do not operate any heat welder during storms.
- Use extreme caution to avoid burns. The temperature of the super-heated air in this machine can reach approximately 1200 °F (645°C).
- Guard against snagging the power cord.
- If the power cord should become disconnected while the machine is operating, it is desirable to reconnect as quickly as possible, with careful attention to safety, to avoid possible damage from overheating. Switch the machine OFF to avoid arcing when reconnecting to power. Reconnect to power. Turn the power switch ON to resume normal operation.
- Inspect the power cord and connections before each welding session. Repair or replace worn or frayed cords and connectors promptly.
- Although the unit may be a double-insulated design, a ground fault interrupter (GFI) at the power source is still recommended.

**NOTICE:** This equipment is for industrial use only. These instructions are for general information only. Prior to actual operation of the hot-air welding equipment, refer to the operating instructions that are provided by the manufacturer. Handling and use of this equipment is beyond Mule-Hide's control. Mule-Hide does not accept any liability for the results.

All statements herein are expressions of opinion, which by performance and testing are believed to be accurate and reliable, and are presented without any knowledge that such recommended uses may infringe any patent. No warranty of any kind whatsoever, expressed or implied, is made or intended.

## Hand Welder

General Description: The hand-held hot-air welder is an electrical powered, hand-held device that utilizes electrical resistance heating and fan-forced, super-heated air to heat Mule-Hide heat-weld membranes. A hand-held rubber roller is used in conjunction with the welder to apply the pressure that fuses the heated Mule-Hide heat-weld membrane surfaces to each other.

The hand-held welder is used as general practice to touch up imperfect seams. It is also used when the self-propelled automatic model is inappropriate, such as in roofing details and on highly sloped surfaces.

## Technical Specifications:

- **Electrical requirements:** 115V, 15A (minimum fused), 2,500 W (minimum recommended available power), single-phase current. If using a generator, ensure generator is capable of providing adequate wattage for

using the automatic welder and hand gun(s) at the same time.

- **Power cord and extensions:** #12, 3-conductor type may be used for distances up to 100 ft.
- **Adjustments:** Temperature of heating element and air flow louvers (and therefore hot air output).
- **Accessories:** 3/4-in. (20-mm) nozzle (for welding details), 1-1/2-in. (40-mm) nozzle (for straight welding, as when repairing field seams), hand-held silicone rubber roller.
- **Welding speed:** Speed will vary according to ambient weather conditions, element control settings and user proficiency.

## Procedure - Before Connecting to Power

Use the hand-held hot-air welder to repair and/or make all seams that cannot be made by the automatic welders. Be sure to take the following preliminary steps before plugging in the equipment:

1. Fit the appropriate nozzle. In general, the 1-1/2-in. (40 mm) nozzle should be fitted to the welder when making or repairing straight welds; the 3/4-in. (20 mm) nozzle should be fitted when welding flashing details.
2. Be sure the power is OFF and the heat adjustment switch is set to ZERO.

**Checkpoint:** At this point, it is assumed the seam is ready to hot-air weld, and the following requirements have been met:

- All fasteners are in place and the two surfaces to be welded are in position.
- The surfaces to be hot-air welded are clean, free of adhesive (a potential problem with flashing details) and other contaminants. If these surfaces are dirty or contaminated, they must be rag-wiped clean with Fantastik® or similar general cleaner, then wiped with a clean rinse rag and dried thoroughly. The seam area should then be wiped with a clean rag dampened with Mule-Hide Membrane Cleaner to ensure removal of any remaining dirt or soap film.
- During the warm-up period, hot air from the welder should be directed in a safe direction.
- A rubber hand roller is available.

**WARNING:** Never touch the metal portion of the fan housing, blower tube or blower nozzle. They become extremely hot and can cause severe burns.

## Procedure - Connecting to Power

With the preliminaries done, begin hot-air welding.

1. Connect the machine to power. Ensure that the welder is pointed in a safe, unobstructed direction.
2. Switch the power on. Turn the power switch ON and turn the heat adjustment switch to its highest position.
3. Warm-up the welder for 5 minutes.

**NOTE:** When first starting out or when welding confined work areas such as corners and pipe penetrations, it is advisable to turn the heat setting down a few notches to avoid applying too much heat.

4. Insert the nozzle into the lap approximately 2" back from the edge of the membrane to create an air dam. Position the nozzle between the surfaces to be welded and quickly position the hand roller on the outer membrane about 1/8 to 1/4 in. from the end of the nozzle.

**NOTE:** More heat is needed when beginning a weld than after a weld is underway, because the membrane is cool. In addition, the super-heated air has an easy escape before a seam is formed. As welding proceeds, the membrane warms up and the hot air from the welder is partially trapped by the seam. Be prepared to pick up the pace.

5. Roll the seam. When the membrane becomes softened, apply a firm pressure to the roller and roll it across the seam in strokes about 3 in. long.
6. After finishing the first pass down the seam to create the air dam, repeat the process to complete the seam. When making the final pass down the seam, keep a small (1/8") portion of the tip exposed beyond the edge of the membrane to ensure a complete weld all the way across the seam.
7. Adjust seaming speed to produce the best weld. As the seaming continues, some trial-and-error adjustment of seaming speed will be required. The membrane surfaces must be heated sufficiently to permit the roller pressure to fuse them together, yet the membrane must not be overheated.

### Rules-of-Thumb for Judging Seam Quality

- The seamed membrane is not discolored, increase seaming speed if membrane discolors (yellow-brown).
  - Bubbles and thinning: Overheating the membrane causes small bubbles and overstretching to the point of leaving too little sheet thickness, especially when working with unreinforced material. Another sign of overheating is a darkened "smeared" appearance on the seam.
  - Voids and wrinkles. A good seam has no voids or wrinkles. If voids or wrinkles are present, see "Repairing Voids and Wrinkles."
8. Clean the nozzle frequently. As with the automatic welding machine, the nozzle of the hand welder should be wire-brushed frequently to remove hot particles of the Mule-Hide heat-weld compound that may adhere to it. If not removed, such particles are likely to be deposited by the nozzle; the presence of such burned particles in the seam can affect seam integrity.
  9. Cool the welder down. When the welder is to be shut down at the completion of a period of welding - turn the temperature adjustment dial to its lowest setting. The heating element will shut off, but the blower will continue to operate, cooling the heating element. Set the welder down so that hot air from the welder is pointed in a safe direction. After about five minutes, turn the power switch OFF.

## Precautions

As with any high-power electrical equipment used outdoors, use accepted practice and common sense to avoid injury. Some suggestions:

- Do not operate any heat-welding equipment during storms.
- Use extreme caution to avoid burns. The temperature of the super-heated air in this machine can reach approximately 800°F (427°C).
- Guard against snagging the power cord.
- If the power cord should become disconnected while the machine is operating, it is desirable to reconnect as quickly as possible, with careful attention to safety, to avoid possible damage from overheating. Switch the machine OFF to avoid arcing when reconnecting to power. Reconnect to power. Turn the power switch ON to resume normal operation.
- Inspect the power cord and connections before each welding session. Repair or replace worn or frayed cords and connectors promptly.
- Use of a GFI at the power source is recommended.

**NOTICE:** This equipment is for industrial use only. These instructions are for general information only. Prior to actual operation of the hand-held welding equipment, refer to the operating instructions that are provided by the manufacturer. Handling and use of this equipment is beyond Mule-Hide's control. Mule-Hide does not accept any liability for the results.

All statements herein are expressions of opinion, which by performance and testing are believed to be accurate and reliable, and are presented without any knowledge that such recommended uses may infringe any patent. No warranty of any kind whatsoever, expressed or implied, is made or intended.

## Seam Probing

General Description: the probing of hot-air welded seams is an important step in the application of a Mule-Hide roof, and is your best insurance for successful inspection.

**SEAMS WITH VOIDS AND WRINKLES HAVE BEEN THE MOST COMMON DEFECTS CITED BY MULE-HIDE INSPECTORS OVER THE YEARS.**

To ensure consistently high-quality seaming on the job, be sure that ALL seams are probed with an appropriate seam probing tool each work day, and all deficiencies noted/marked with a water-soluble marker and repaired as promptly as possible with a hand-held, hot-air welder. Mule-Hide recommends that seams are probed with a cotter pin puller.

### Procedure - Probing the Seams

The probing of seams should not be done until the hot-air welds have thoroughly cooled. As a general procedure, seam probing and repair of deficiencies should be done for all seams approximately 8 hours after they are initially welded.

**WARNING:** Premature probing can open warm seams that would have been perfectly acceptable once they had cooled.

1. Draw probing tool tip along seams. Gripping the probing tool by the handle, draw its tip along the edge of the hot-air welded seam. Apply firm pressure into the seam junction - not into the bottom sheet. The tool should not penetrate into the lap area.
2. Mark deficiencies. Using a water-soluble marker, mark off the beginning and end of each void.
4. Repair deficiencies promptly. Using a hand-held welder, repair all seam deficiencies as quickly as possible. Mule-Hide requires that repairs be made the same day that they are discovered.
5. Check repairs. After the repaired seams have cooled completely, probe them again. If the repair is successful, wipe off the water-soluble marker line; if not, do the repair over.

**NOTES:**

---

---

---

---

---

---

---

---

---

---

---

---

---

---

---

---

---

---

---

---

---

---

---

---

---

---

---



**NOTES:**

---

---

---

---

---

---

---

---

---

---

---

---

---

---

---

---

---

---

---

---

---

---

---

---

---



# TPO Minimum Membrane Fastening Requirements Standard Wind Speed (55 MPH Coverage)

Roof Deck	Roof Height	Width of Field Sheet	Fastener Spacing
<b>Steel Roof Decks</b>			
Steel Min 22 Guage	Up to 60'	12'	6" oc
		10'	12" oc
		8'	12" oc
	61' - 100'	12'	6" oc
		10'	6" oc
		8'	6" oc
Steel Less than 22 Guage	0' to 100'	Pull test required Contact Mule-Hide for additional information	
<b>Wood Roof Decks</b>			
2X Plank 3/4" Plywood	Up to 60'	12'	6" oc
		10'	12" oc
		8'	12" oc
	61' - 100'	12'	6" oc
		10'	6" oc
		8'	12" oc
5/8" Plywood	Up to 60'	10'	12" oc
		8'	12" oc
	61' - 100'	10'	6" oc
		8'	12" oc
1X Plank 1/2" Plywood	Up to 60'	10'	6" oc
		8'	12" oc
	61' - 100'	8'	6" oc
OSB	0' - 100'	Contact Mule-Hide Technical Department prior to starting work	

<b>Structural Concrete Roof Decks</b>			
2500 psi 2" Min Pour or Precast	Up to 60'	12'	12" oc
		10'	12" oc
		8'	12" oc
	61' - 100'	12'	6" oc
		10'	6" oc
		8'	12" oc
<b>Insulating Concrete (Fasteners must penetrate from deck)</b>			
Steel from Deck	0' - 100'	Pull test required Contact Mule-Hide for additional information	
<b>Other Roof Decks</b>			
Gypsum Concrete Cementitous Wood Fiber	0' - 100'	Pull test required Contact Mule-Hide for additional information	

# Perimeter Enhancement Requirements Mechanically Attached System With 55-MPH Wind Speed Coverage

Building Height	Minimum Perimeter Enhancement Required
0' - 34'	1 perimeter sheet
	1 perimeter enhancement width
35' - 100'	2 perimeter sheets (wind zones up to 100 mph)
	2 perimeter enhancement widths (wind zones up to 100 mph)
Higher than 100' or Higher Wind Zones	Contact Mule-Hide Technical Department

Width of Field Sheet	Perimeter Sheet Width (2)	Perimeter Enhancement Width	
		10" RUSS	Plates/Fasteners Through Membrane
4'	N/A	2'	2'
6'	N/A	3'	3'
8'	4'	4'	4'
10'	6'	5'	5'
12'	6'	6'	6'

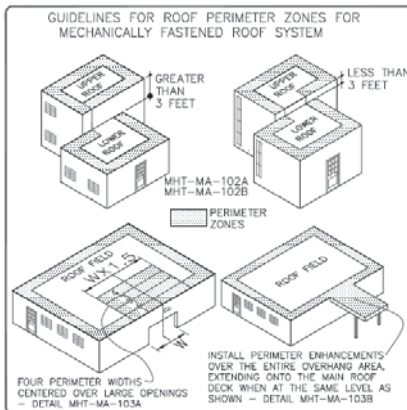

PERIMETER HALF SHEETS  
 MH 2.4" SEAM PLATES & HDP OR EHD FASTENERS

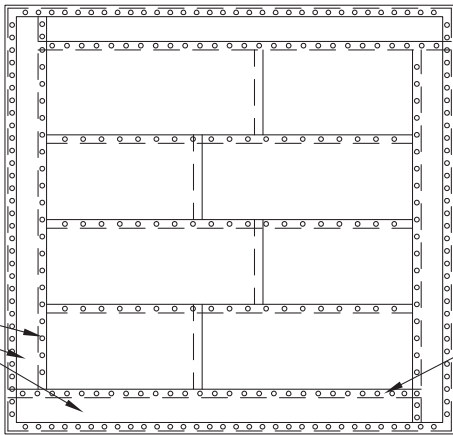

PARAPET WALL BASE FLASHING  
 HEAT WELDED SEAMS

NOTE:

SEE TPO MEMBRANE FASTENING TECHNICAL BULLETIN #TPO-MA01-2006 FOR APPROPRIATE FASTENER SPACING FOR VARIOUS DECK TYPES AND WIND UPLIFT REQUIREMENTS.

NOTE:

SEE TECHNICAL BULLETIN #TPO-MA02-2006 FOR PERIMETER ENHANCEMENT REQUIREMENTS.

NOTE:

THIS DETAIL IS NOT APPROVED OVER STEEL ROOF DECKS. FOR STEEL ROOF DECKS, REFER TO DETAILS MHT-FM-308A OR B;

FIELD MEMBRANE LAYOUT  
 PERIMETER HALF SHEET OPTION

SYSTEMS:

MECHANICALLY ATTACHED

DETAIL NO.:

**MHT-MA-101A**

REVISION DATE: 10/2013

**MULE-HIDE  
 PRODUCTS CO., INC.**

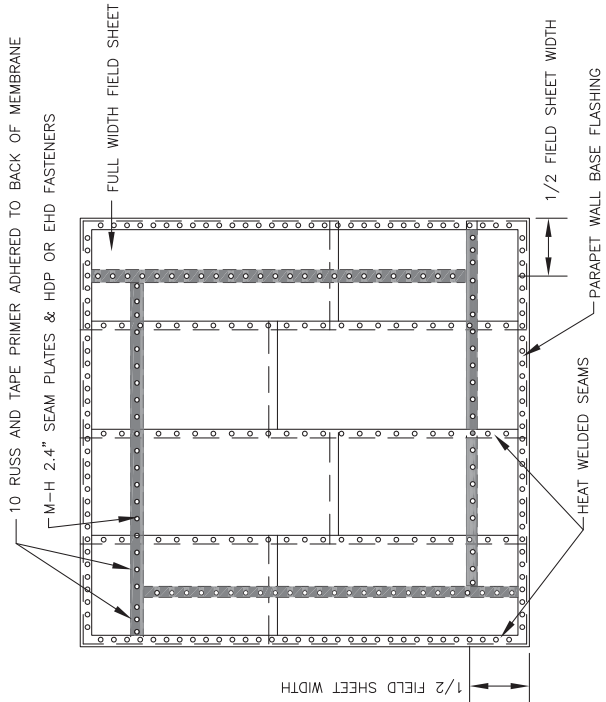

NOTE:

SEE TPO MEMBRANE FASTENING TECHNICAL BULLETIN #TPO-MA01-2006 FOR APPROPRIATE FASTENER SPACING FOR VARIOUS DECK TYPES AND WIND UPLIFT REQUIREMENTS.

SEE TECHNICAL BULLETIN #TPO-MA02-2006 FOR PERIMETER ENHANCEMENT REQUIREMENTS.

NOTE:

RUSS PRODUCTS CANNOT BE USED ON FLEECEBACK OR SELF ADHERING MEMBRANES

NOTE:

THIS DETAIL IS NOT APPROVED OVER STEEL ROOF DECKS. FOR STEEL ROOF DECKS, REFER TO DETAIL MHT-FM-308A.

<b>MULE-HIDE PRODUCTS CO., INC.</b>	<b>PERIMETER SECUREMENT 10" RUSS STRIP SYSTEMS:</b>	<b>DETAIL NO.:</b> <b>MHT-MA-101B</b>
	<b>MECHANICALLY ATTACHED</b>	REVISION DATE: 10/2013

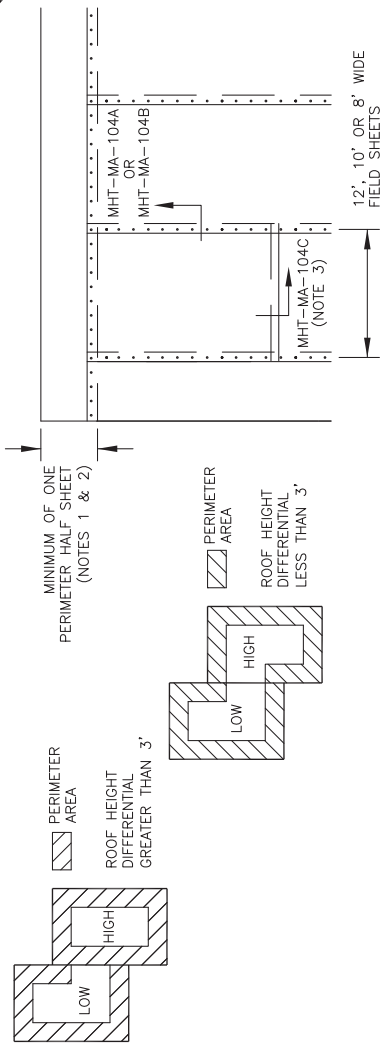

NOTES:

1. REFER TO MULE-HIDE TECHNICAL BULLETIN #TPO-MA02-2006 FOR MINIMUM PERIMETER ENHANCEMENT REQUIREMENTS.
2. CONTACT MULE-HIDE FOR FM OR CODE COMPLIANCE FOR REQUIRED NUMBER OF PERIMETER HALF SHEETS AND MEMBRANE FASTENING.
3. SECUREMENT NOT REQUIRED AT END LAPS; OVERLAP MEMBRANE 2" TO 3". REFER TO DETAIL MHT-UN-104C.
4. FOR INSULATION SECUREMENT, REFER TO MHT-MA-700 AND MHT-MA-701 DETAILS.
5. IF A FACTORY MUTUAL RATING IS REQUIRED, CONTACT MULE-HIDE TECHNICAL DEPARTMENT FOR CORNER REQUIREMENTS.
6. THIS OPTION IS NOT TO BE USED ON STEEL DECKS. REFER TO DETAIL MHT-FM-108A.

DETAIL NO.:  
**MHT-MA-102A**  
 REVISION DATE: 10/2013

PERIMETER ATTACHMENT  
 OPTION 1 - PERIMETER HALF SHEETS  
 SYSTEMS:  
 MECHANICALLY ATTACHED

**MULE-HIDE**  
**PRODUCTS CO., INC.**



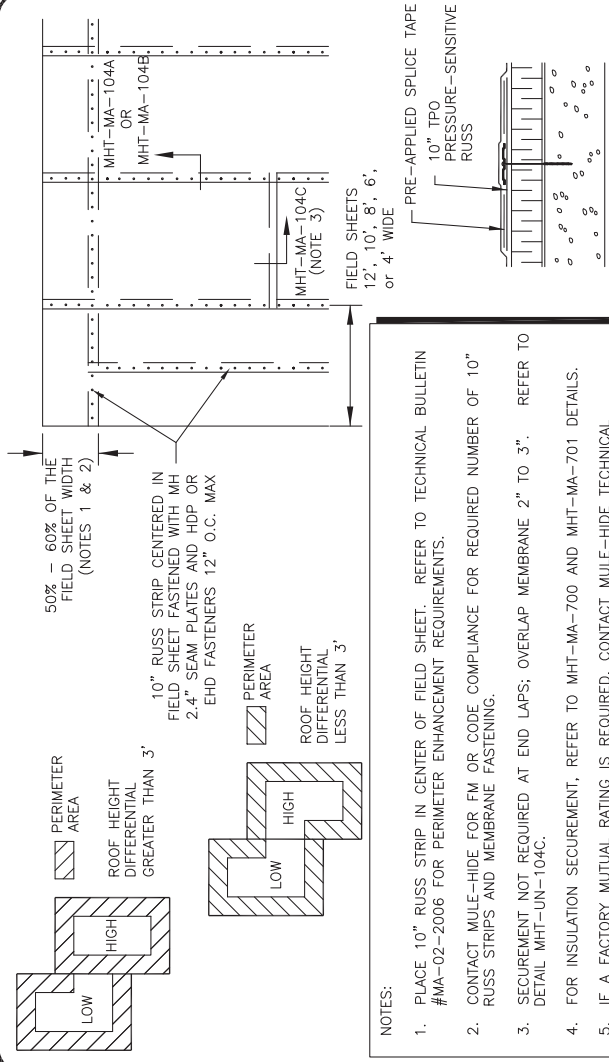

- NOTES:
1. PLACE 10" RUSS STRIP IN CENTER OF FIELD SHEET. REFER TO TECHNICAL BULLETIN #MA-02-2006 FOR PERIMETER ENHANCEMENT REQUIREMENTS.
  2. CONTACT MULE-HIDE FOR FM OR CODE COMPLIANCE FOR REQUIRED NUMBER OF 10" RUSS STRIPS AND MEMBRANE FASTENING.
  3. SECUREMENT NOT REQUIRED AT END LAPS; OVERLAP MEMBRANE 2" TO 3". REFER TO DETAIL MHT-UN-104C.
  4. FOR INSULATION SECUREMENT, REFER TO MHT-MA-700 AND MHT-MA-701 DETAILS.
  5. IF A FACTORY MUTUAL RATING IS REQUIRED, CONTACT MULE-HIDE TECHNICAL DEPARTMENT FOR CORNER REQUIREMENTS.
  6. RUSS PRODUCTS CANNOT BE USED WITH FLEECEBACK OR SELF ADHERING MEMBRANES.
  7. THIS OPTION IS NOT TO BE USED ON STEEL DECK. REFER TO DETAIL MHT-FM-108A.

PERIMETER ATTACHMENT - OPTION 2  
10" RUSS STRIP ALTERNATE SYSTEMS:

MECHANICALLY ATTACHED

DETAIL NO.:  
**MHT-MA-102B**  
REVISION DATE: 10/2013

**MULE-HIDE PRODUCTS CO., INC.**

NOTES:

1. WHEN ANY WALL CONTAINS MAJOR OPENINGS WITH A COMBINED AREA WHICH EXCEEDS 10% OF THE TOTAL WALL AREA ON WHICH THE OPENINGS ARE LOCATED, A MINIMUM OF 4 PERIMETER HALF SHEETS OR ENHANCEMENT WIDTHS MUST BE CENTERED OVER THE OPENING.
2. THE DEPTH OF THE PERIMETER ENHANCEMENT MUST BE A MINIMUM OF 2.5 TIMES THE WIDTH OF THE OPENING OR 4 PERIMETER HALF SHEETS/ENHANCEMENT WIDTHS, WHICHEVER IS LARGER.
3. AS AN OPTION, AN ADHERED MEMBRANE SECTION MAY BE USED IN LIEU OF THE MECHANICALLY FASTENED MEMBRANE AT LARGE OPENINGS IN ACCORDANCE WITH THE MULE-HIDE FULLY ADHERED TPO ROOF SYSTEM SPECIFICATION.
4. REFER TO TECHNICAL BULLETIN #TPO-MA02--2006 FOR PERIMETER ENHANCEMENT REQUIREMENTS.

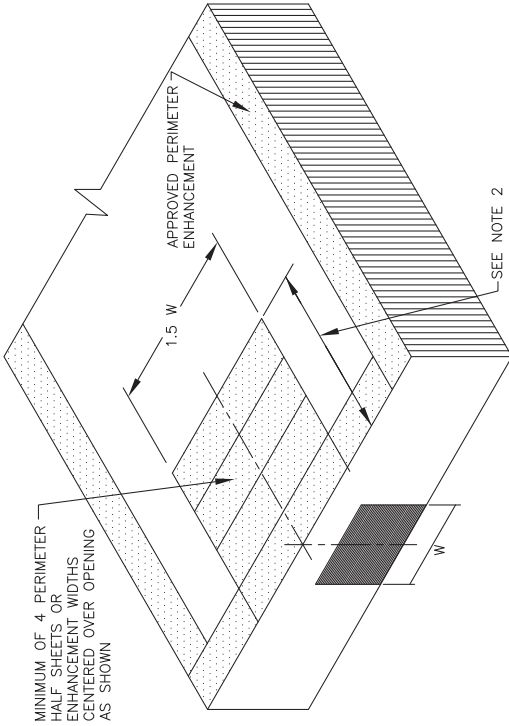

SHEET LAYOUT ON BUILDINGS WITH LARGE OPENINGS SYSTEMS: MECHANICALLY ATTACHED

DETAIL NO.: **MHT-MA-103A**  
 REVISION DATE: 10/2013

**MULE-HIDE PRODUCTS CO., INC.**

NOTES:

1. THE MEMBRANE MUST BE SPECIFIED WITH PERIMETER ENHANCEMENT INSTALLED OVER THE ENTIRE OVERHANG AREA. WHEN THE OVERHANG IS AT THE SAME LEVEL AS THE MAIN ROOF, EXTEND THE PERIMETER ENHANCEMENT ONTO THE MAIN ROOF LEVEL AS SHOWN.
2. AS AN OPTION, AN ADHERED MEMBRANE SECTION MAY BE USED IN LIEU OF THE MECHANICALLY FASTENED MEMBRANE AT BUILDING OVERHANGS IN ACCORDANCE WITH THE MULE-HIDE FULLY ADHERED TPO ROOF SYSTEM SPECIFICATION.
3. REFER TO TECHNICAL BULLETIN #TPO-MA02-2006 FOR PERIMETER ENHANCEMENT REQUIREMENTS.

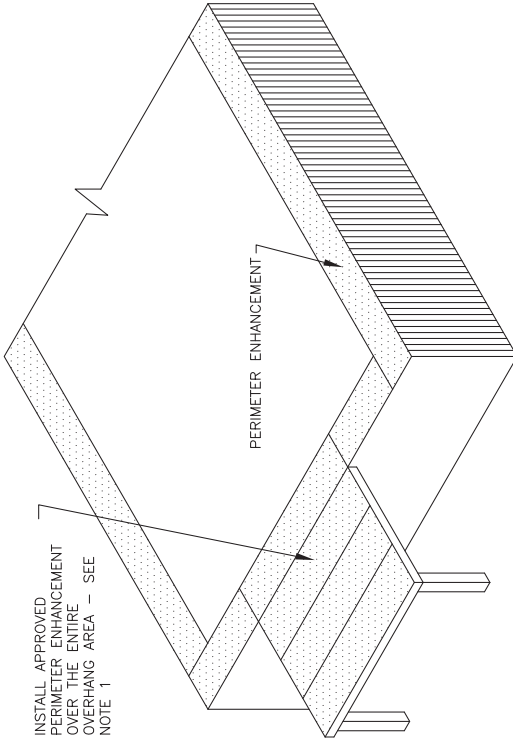

INSTALL APPROVED PERIMETER ENHANCEMENT OVER THE ENTIRE OVERHANG AREA - SEE NOTE 1

PERIMETER ENHANCEMENT

SHEET LAYOUT ON BUILDINGS WITH OVERHANGS SYSTEMS:

MECHANICALLY ATTACHED

DETAIL NO.:

**MHT-MA-103B**

REVISION DATE: 10/2013

**MULE-HIDE PRODUCTS CO., INC.**

NOTES:

1. WHERE MULTI-LEVEL ROOFS MEET AT A COMMON WALL AND THE DIFFERENCE IN HEIGHT IS LESS THAN 3 FT, THE ROOF STRIP OF THE UPPER ROOF AND THE ROOF STRIP OF THE LOWER ROOF ARE EACH TREATED AS FIELD AREAS, EXCEPT FOR THE SQUARE AREAS AT EACH END, WHICH ARE TREATED AS PERIMETER AREAS.
2. FOR FACTORY MUTUAL PROJECTS, THE WIDTH OF THE ROOF PERIMETER AND CORNER AREAS IS DEFINED AS THE SMALLER OF 0.1 TIMES THE BUILDING LESSER PLAN DIMENSION OR 0.4 TIMES THE EAVE HEIGHT (MEAN ROOF HEIGHT FOR SLOPES GREATER THAN 2"/12" SLOPE), EXCEPT FOR HEIGHTS GREATER THAN 60 FT.

3. ROOF PERIMETER

MECHANICALLY ATTACHED SYSTEMS  
 DISTANCE BETWEEN ROWS IS LESS THAN OR EQUAL TO 60% OF THE APPROVED ROOF FIELD SPACING OF THE FASTENER ROWS.

FULLY ADHERED SYSTEMS  
 ALL ROOF PERIMETER DIMENSIONS ARE TO BE A MINIMUM OF EIGHT (8) FEET AND INSULATION FASTENERS ARE INCREASED 50%.

4. ROOF CORNERS

MECHANICALLY ATTACHED SYSTEMS  
 DISTANCE BETWEEN ROWS IS LESS THAN OR EQUAL TO 40% OF THE APPROVED ROOF FIELD SPACING OF THE FASTENER ROWS.

FULLY ADHERED SYSTEMS  
 ALL ROOF CORNER DIMENSIONS ARE TO BE A MINIMUM OF EIGHT (8) FEET BY EIGHT (8) FEET AND INSULATION FASTENERS ARE INCREASED 100%.

5. INCREASED FASTENING IN THE PERIMETERS AND CORNERS IS REQUIRED ON ALL WARRANTED JOBS, BOTH MECHANICALLY ATTACHED AND FULLY ADHERED.

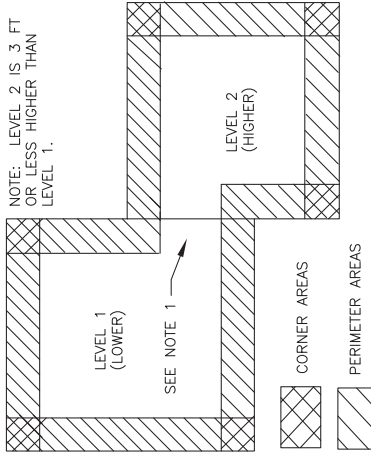

ROOF PERIMETER / CORNER CALCULATION  
 ELEVATION DIFFERENCE 3' OR LESS

SYSTEMS:

ALL TPO SYSTEMS

DETAIL NO.:

**MHT-UN-108A**

REVISION DATE: 10/2013

**MULE-HIDE  
 PRODUCTS CO., INC.**

NOTES:

1. WHERE MULTI-LEVEL ROOFS MEET AT A COMMON WALL AND THE DIFFERENCE IN HEIGHT IS GREATER THAN 3 FT, THE EDGE OF THE UPPER ROOF IS TREATED AS ROOF PERIMETER AND CORNERS. THE LOWER ROOF STRIP WHERE IT MEETS A HIGHER WALL IS TREATED AS FIELD AREA, EXCEPT FOR THE SQUARE AREAS AT EACH END WHICH ARE TREATED AS PERIMETER AREAS.
2. FOR FACTORY MUTUAL PROJECTS, THE WIDTH OF THE ROOF PERIMETER AND CORNER AREAS IS DEFINED AS THE SMALLER OF 0.1 TIMES THE BUILDING LESSER PLAN DIMENSION OR 0.4 TIMES THE EAVE HEIGHT (MEAN ROOF HEIGHT FOR SLOPES GREATER THAN 2"/12" SLOPE), EXCEPT FOR HEIGHTS GREATER THAN 60 FT.
3. ROOF PERIMETER

MECHANICALLY ATTACHED SYSTEMS

DISTANCE BETWEEN ROWS IS LESS THAN OR EQUAL TO 60% OF THE APPROVED ROOF FIELD SPACING OF THE FASTENER ROWS.

FULLY ADHERED SYSTEMS

ALL ROOF PERIMETER DIMENSIONS ARE TO BE A MINIMUM OF EIGHT (8) FEET AND INSULATION FASTENERS ARE INCREASED 50%.

4. ROOF CORNERS

MECHANICALLY ATTACHED SYSTEMS

DISTANCE BETWEEN ROWS IS LESS THAN OR EQUAL TO 40% OF THE APPROVED ROOF FIELD SPACING OF THE FASTENER ROWS.

FULLY ADHERED SYSTEMS

ALL ROOF CORNER DIMENSIONS ARE TO BE A MINIMUM OF EIGHT (8) FEET BY EIGHT (8) FEET AND INSULATION FASTENERS ARE INCREASED 100%.

5. INCREASED FASTENING IN THE PERIMETERS AND CORNERS IS REQUIRED ON ALL WARRANTED JOBS, BOTH MECHANICALLY ATTACHED AND FULLY ADHERED.

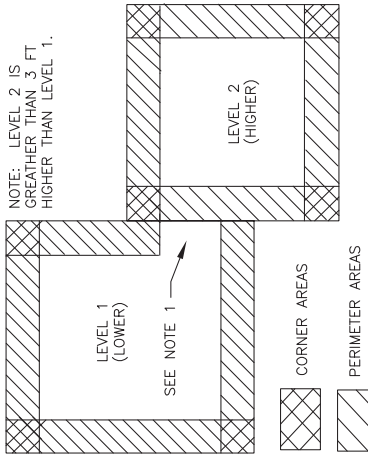

**ROOF PERIMETER / CORNER CALCULATION  
ELEVATION DIFFERENCE GREATER THAN 3'  
SYSTEMS:**

**ALL TPO SYSTEMS**

**DETAIL NO.:**

**MHT-UN-108B**

REVISION DATE: 10/2013

**MULE-HIDE  
PRODUCTS CO., INC.**

NOTES:

1. DETAILS TO BE USED IN CONJUNCTION WITH STANDARD GUIDE SPECIFICATIONS CONTAINING REQUIREMENTS FOR NAILERS, INSULATION, SLIPSHEETS, ETC.
2. ACCORDING TO PROJECT CONDITIONS, THE SPECIFIER AND/OR APPLICATOR MUST IDENTIFY THE WIDTH DIMENSIONS OF THE ROOF PERIMETERS AND CORNERS IN ACCORDANCE WITH FM DATA SHEETS 1-28 AND 1-29 BASED UPON THE FOLLOWING FORMULA:
  - 0.4 TIMES THE BUILDING HEIGHT OR
  - 0.1 TIMES THE BUILDING'S LESSER PLAN DIMENSION, WHICHEVER IS SMALLER

THE MINIMUM PERIMETER/CORNER WIDTH SHALL BE NO LESS THAN 3 FEET

3. FOR STEEL DECKS:
  - ALL FASTENERS MUST ENGAGE TOP FLUTES OF DECK
  - IN THE FIELD OF THE ROOF, SEAMS (FASTENER ROWS) MUST RUN PERPENDICULAR TO THE DECK FLUTES
  - PERIMETER HALF SHEETS ARE TO BE USED ONLY ON SIDES OF ROOF WHEN THE SEAMS RUN PERPENDICULAR TO THE DECK FLUTES
4. 10" WIDE TPO PRESSURE-SENSITIVE RUSS CAN BE USED BENEATH FIELD SHEETS IN LIEU OF FASTENERS AND PLATES INSTALLED THROUGH THE MEMBRANE OR PERIMETER HALF SHEETS.
5. USE ADDITIONAL HALF SHEETS INSTALLED WITH SEAMS RUNNING PERPENDICULAR TO THE DECK FLUTES TO MEET OR SLIGHTLY EXCEED FM PERIMETER DIMENSION REQUIREMENTS AS OUTLINED IN NOTE 2 ABOVE.  
EXAMPLE: A 14' PERIMETER DIMENSION WOULD REQUIRE FOUR 4' PERIMETER SHEETS (14' DIVIDED BY 3.5" COVERAGE PROVIDED BY A 4' WIDE SHEET)

REFER TO MULE-HIDE TECHNICAL BULLETIN #TPO-MA02-2006 FOR PERIMETER ENHANCEMENT REQUIREMENTS

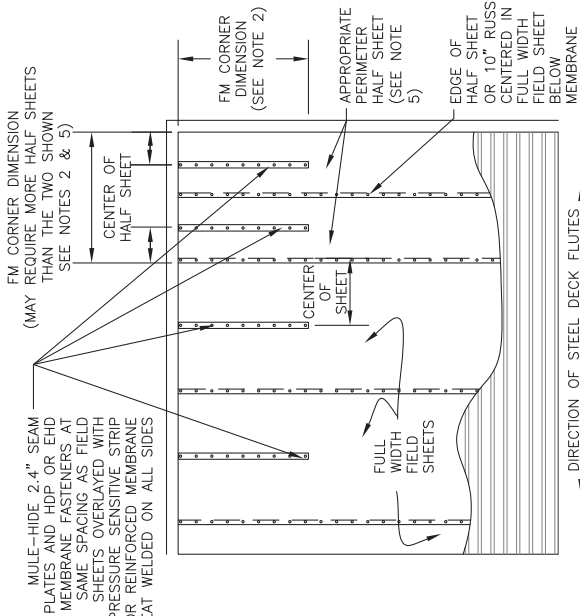

<p><b>MULE-HIDE PRODUCTS CO., INC.</b></p>	<p>FM CORNER / PERIMETER FASTENING ENHANCEMENTS - OPTION A SYSTEMS:</p>	<p>DETAIL NO.: <b>MHT-FM-308A</b></p>
	<p>TPO MECHANICALLY ATTACHED</p>	<p>REVISION DATE: 10/2013</p>

NOTES:

1. DETAILS TO BE USED IN CONJUNCTION WITH STANDARD GUIDE SPECIFICATIONS CONTAINING REQUIREMENTS FOR NAILERS, INSULATION, SLIPSHEETS, ETC.
2. ACCORDING TO PROJECT CONDITIONS, THE SPECIFIER AND/OR APPLICATOR MUST IDENTIFY THE WIDTH DIMENSIONS OF THE ROOF PERIMETERS AND CORNERS IN ACCORDANCE WITH FM DATA SHEETS 1-28 AND 1-29 BASED UPON THE FOLLOWING FORMULA:

- 0.4 TIMES THE BUILDING HEIGHT OR
- 0.1 TIMES THE BUILDING'S LESSER PLAN DIMENSION, WHICHEVER IS SMALLER

THE MINIMUM PERIMETER/CORNER WIDTH SHALL BE NO LESS THAN 3 FEET

3. FOR STEEL DECKS:

- ALL FASTENERS MUST ENGAGE TOP FLUTES OF DECK
- IN THE FIELD OF THE ROOF, SEAMS (FASTENER ROWS) MUST RUN PERPENDICULAR TO THE DECK FLUTES
- PERIMETER HALF SHEETS ARE TO BE USED ONLY WHEN THE SEAMS RUN PERPENDICULAR TO THE DECK FLUTES

4. 10" WIDE TPO PRESSURE-SENSITIVE RUSS CAN BE USED BENEATH FIELD OR PERIMETER SHEETS IN LIEU OF FASTENERS AND PLATES INSTALLED THROUGH THE MEMBRANE.

5. USE ADDITIONAL HALF SHEETS INSTALLED WITH SEAMS RUNNING PERPENDICULAR TO THE DECK FLUTES TO MEET OR SLIGHTLY EXCEED FM PERIMETER DIMENSION REQUIREMENTS AS OUTLINED IN NOTE 2 ABOVE. EXAMPLE: A 14' PERIMETER DIMENSION WOULD REQUIRE FOUR 4' PERIMETER SHEETS (14' DIVIDED BY 3'6" COVERAGE PROVIDED BY A 4' WIDE SHEET)

REFER TO MULE-HIDE TECHNICAL BULLETIN #TPO-MA02-2006 FOR PERIMETER ENHANCEMENT REQUIREMENTS

MULE-HIDE 2.4" SEAM PLATES AND HDP OR EHD MEMBRANE FASTENERS AT SAME SPACING AS FIELD SHEETS OVERLAYED WITH PRESSURE SENSITIVE STRIP OR REINFORCED MEMBRANE HEAT WELDED ON ALL SIDES (SEE NOTE 4)

FM CORNER DIMENSION (MAY REQUIRE MORE HALF SHEETS THAN THE TWO SHOWN (SEE NOTES 2 & 5))

CENTER OF HALF SHEET

APPROPRIATE SIZED HALF SHEETS INSTALLED PERPENDICULAR TO DECK FLUTES

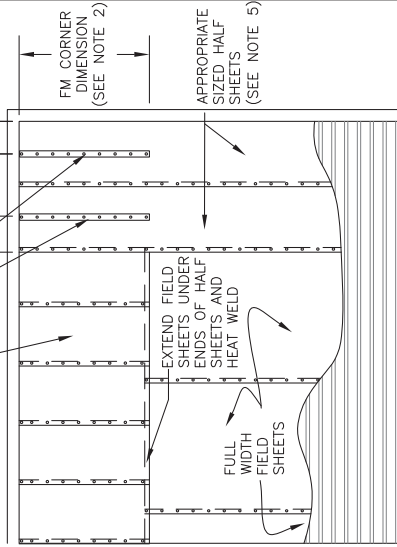

DIRECTION OF STEEL DECK FLUTES

<p><b>MULE-HIDE PRODUCTS CO., INC.</b></p>	<p><b>FM CORNER / PERIMETER FASTENING ENHANCEMENTS - OPTION B SYSTEMS:</b></p>	<p><b>DETAIL NO.:</b> <b>MHT-FM-308B</b></p>
	<p><b>TPO MECHANICALLY ATTACHED</b></p>	<p>REVISION DATE: 10/2013</p>

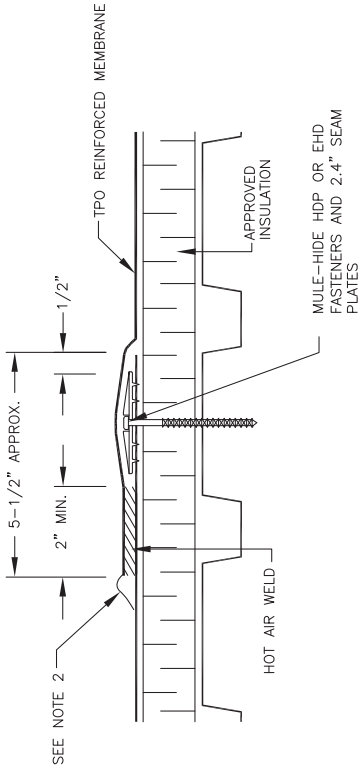

NOTES:

1. REFER TO MULE-HIDE TECHNICAL BULLETIN TPO-MA01-2006 FOR SHEET SIZE AND FASTENER SIZE REQUIRED FOR UPLIFT RESISTANCE. IF A FACTORY MUTUAL RATING OR CODE COMPLIANCE IS REQUIRED, CONTACT MULE-HIDE FOR SPECIFIC REQUIREMENTS.
2. APPROXIMATELY 1/8" DIAMETER BEAD OF CUT-EDGE SEALANT IS REQUIRED ON CUT EDGES OF TPO REINFORCED MEMBRANE.
3. A ROBOTIC WELDER MUST BE USED TO COMPLETE ALL FIELD SEAMS ON ALL WARRANTED PROJECTS.

<b>MULE-HIDE PRODUCTS CO., INC.</b>	<b>FIELD SEAM ATTACHMENT</b>	<b>DETAIL NO.:</b> <b>MHT-MA-104A</b>
	<b>SYSTEMS:</b> <b>MECHANICALLY ATTACHED</b>	REVISION DATE: 10/2013



NOTE:

1. REFER TO MULE-HIDE TECHNICAL BULLETIN TPO-MA01-2006 FOR SHEET SIZE, FASTENER TYPE AND SIZE AND SPACING REQUIRED FOR UPLIFT RESISTANCE. IF A FACTORY MUTUAL RATING OR CODE COMPLIANCE IS REQUIRED, CONTACT MULE-HIDE FOR SPECIFIC REQUIREMENTS.
2. POSITION 2.4" SEAM PLATES 1/2" FROM EDGE OF MEMBRANE.
3. A ROBOTIC WELDER MUST BE USED TO COMPLETE ALL FIELD SEAMS ON ALL WARRANTED PROJECTS.

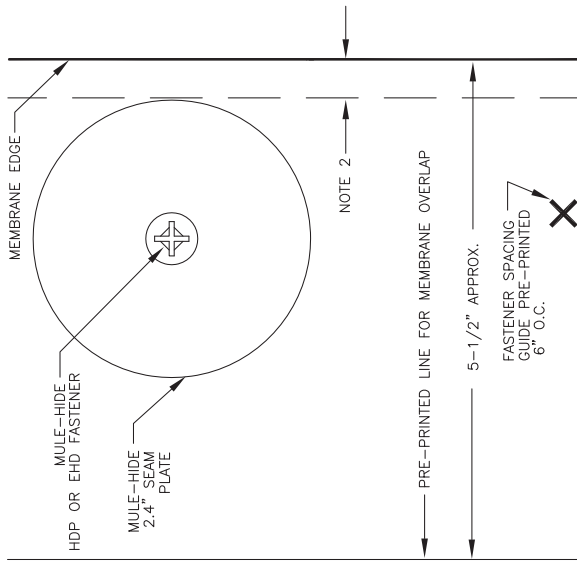

<b>MULE-HIDE PRODUCTS CO., INC.</b>	<b>FIELD SEAM - PLATE POSITION</b>	<b>DETAIL NO.:</b> <b>MHT-MA-104B</b>
	<b>SYSTEMS:</b> <b>MECHANICALLY ATTACHED</b>	REVISION DATE: 10/2013

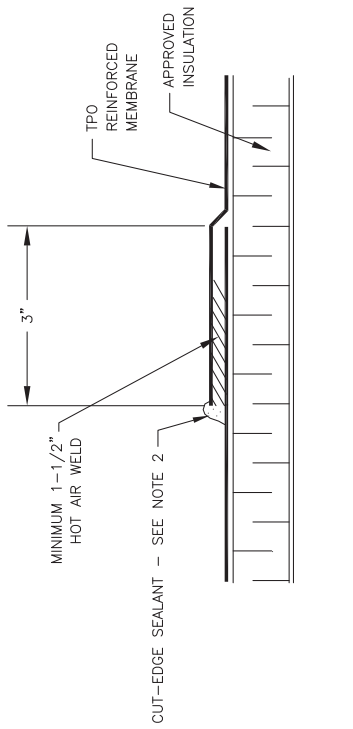

NOTE:

1. APPROXIMATELY 1/8" DIAMETER BEAD OF CUT-EDGE SEALANT IS REQUIRED ON CUT EDGES OF TPO REINFORCED MEMBRANE.
2. A ROBOTIC WELDER MUST BE USED TO COMPLETE ALL FIELD SEAMS ON ALL WARRANTED PROJECTS.

<b>MULE-HIDE PRODUCTS CO., INC.</b>	FIELD SEAM	DETAIL NO.:
	SYSTEMS: FULLY ADHERED	<b>MHT-FA-104D</b> REVISION DATE: 10/2013

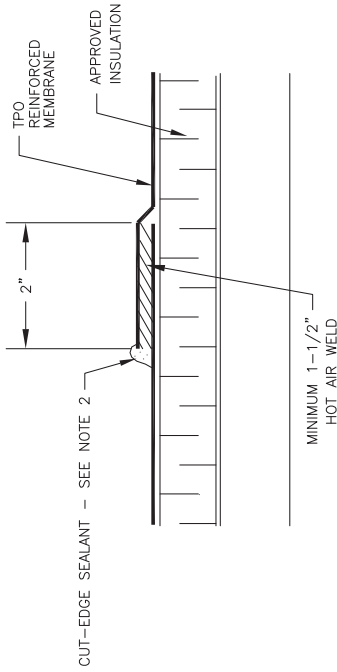

NOTE:

1. IT IS NOT NECESSARY TO FASTEN MEMBRANE AT END LAPS.
2. APPROXIMATELY 1/8" DIAMETER BEAD OF CUT-EDGE SEALANT IS REQUIRED ON CUT EDGES OF TPO REINFORCED MEMBRANE.

DETAIL NO.:

**MHT-UN-104C**

REVISION DATE: 10/2013

END LAPS

SYSTEMS:  
ALL TPO SYSTEMS  
EXCEPT FLEECEBACK AND SELF ADHERING

**MULE-HIDE  
PRODUCTS CO., INC.**

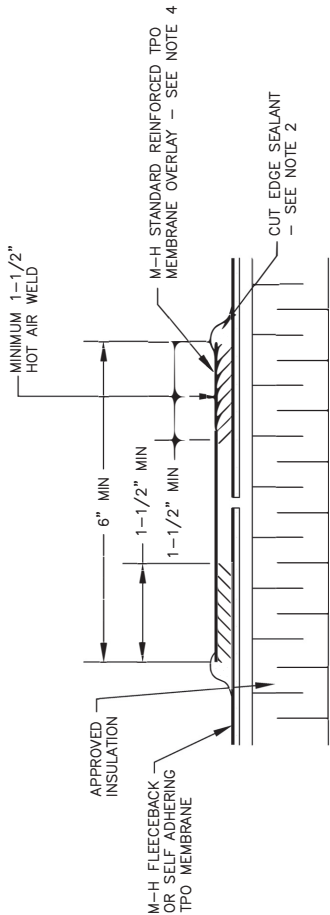

- NOTE:
1. IT IS NOT NECESSARY TO FASTEN MEMBRANE AT END LAPS.
  2. APPROXIMATELY 1/8" DIAMETER BEAD OF CUT-EDGE SEALANT IS REQUIRED ON CUT EDGES OF TPO REINFORCED MEMBRANE.
  3. A ROBOTIC WELDER MUST BE USED TO COMPLETE ALL FIELD SEAMS ON ALL WARRANTED PROJECTS.
  4. THICKNESS OF STANDARD REINFORCED TPO MEMBRANE TO MATCH THICKNESS OF FLEECEBACK OR SELF-ADHERING TPO MEMBRANE.

<b>MULE-HIDE PRODUCTS CO., INC.</b>	<b>END LAPS</b>	<b>DETAIL NO.:</b> <b>MHT-JUN-104E</b>
	<b>SYSTEMS:</b> <b>ALL TPO FLEECE BACK AND SELF ADHERING</b>	REVISION DATE: 05/2016

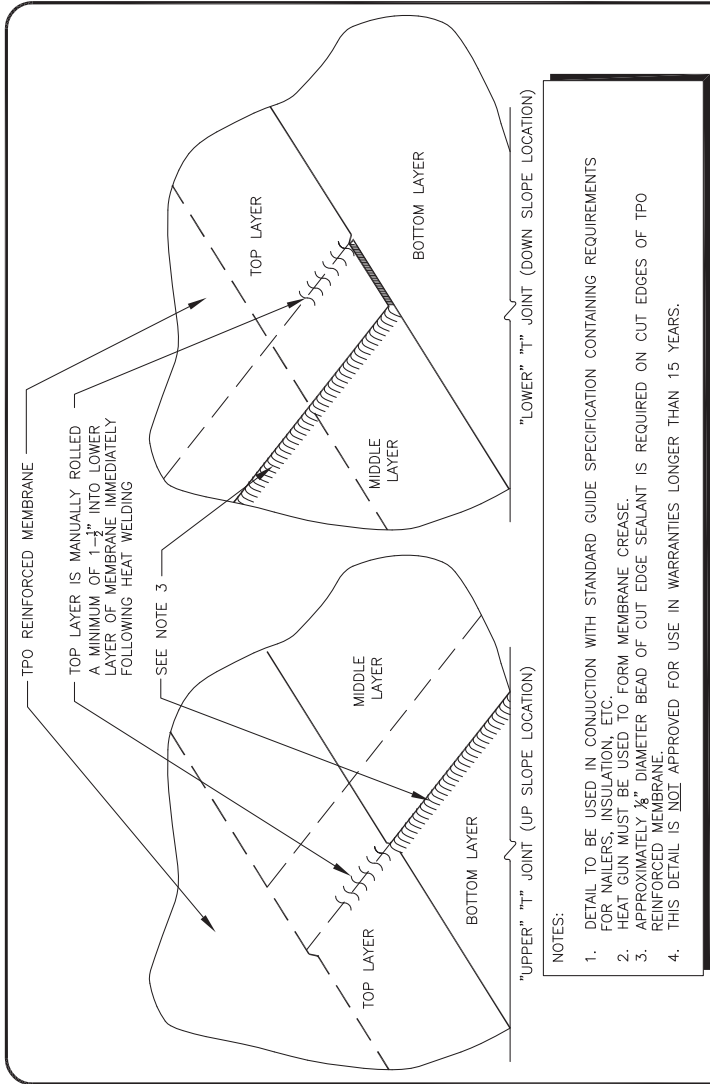

- NOTES:
1. DETAIL TO BE USED IN CONJUNCTION WITH STANDARD GUIDE SPECIFICATION CONTAINING REQUIREMENTS FOR NAILERS, INSULATION, ETC.
  2. HEAT GUN MUST BE USED TO FORM MEMBRANE CREASE.
  3. APPROXIMATELY  $\frac{1}{8}$ " DIAMETER BEAD OF CUT EDGE SEALANT IS REQUIRED ON CUT EDGES OF TPO REINFORCED MEMBRANE.
  4. THIS DETAIL IS NOT APPROVED FOR USE IN WARRANTIES LONGER THAN 15 YEARS.

<b>MULE-HIDE PRODUCTS CO., INC.</b>	<b>"T" JOINT DETAIL</b> .045" (45 MIL) THICK MEMBRANES SYSTEMS: ALL TPO SYSTEMS	<b>DETAIL NO.:</b> <b>MHT-UN-105A</b> REVISION DATE: 10/2013

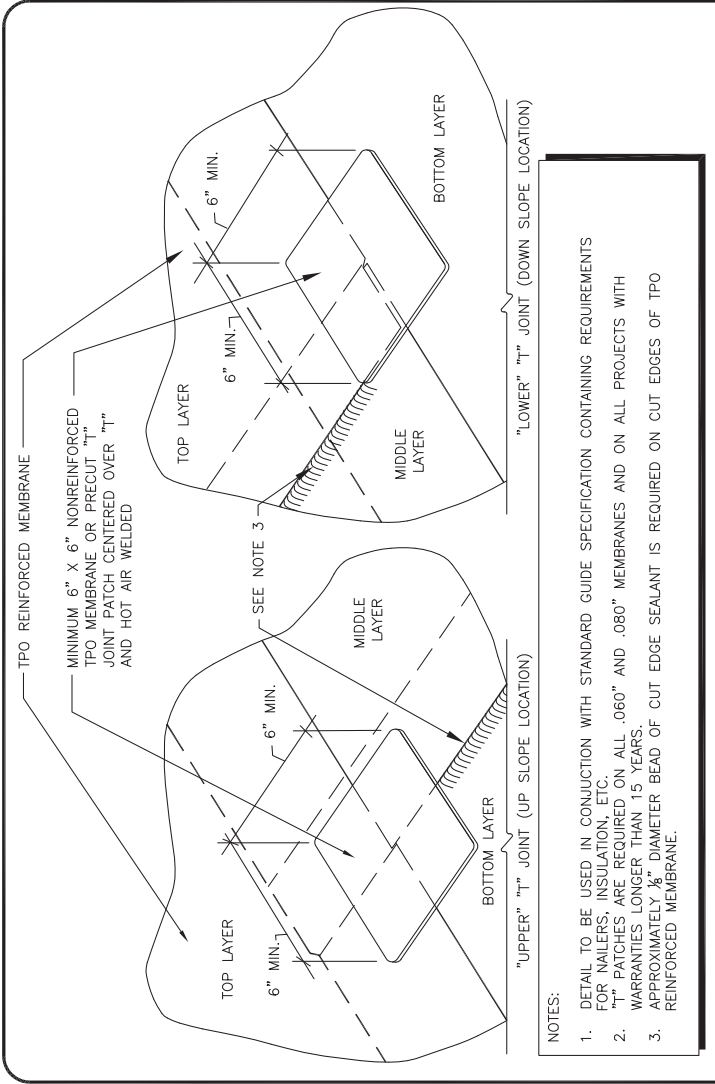

- NOTES:
1. DETAIL TO BE USED IN CONJUNCTION WITH STANDARD GUIDE SPECIFICATION CONTAINING REQUIREMENTS FOR MAILERS, INSULATION, ETC.
  2. "T" PATCHES ARE REQUIRED ON ALL .060" AND .080" MEMBRANES AND ON ALL PROJECTS WITH WARRANTIES LONGER THAN 15 YEARS.
  3. APPROXIMATELY 1/8" DIAMETER BEAD OF CUT EDGE SEALANT IS REQUIRED ON CUT EDGES OF TPO REINFORCED MEMBRANE.

<b>MULE-HIDE PRODUCTS CO., INC.</b>	<b>"T" JOINT COVER PATCH .060" (60 MIL) OR THICKER MEMBRANES SYSTEMS:</b>	<b>DETAIL NO.:</b> <b>MHT-UN-105B</b>
	<b>ALL TPO SYSTEMS</b>	REVISION DATE: 10/2013

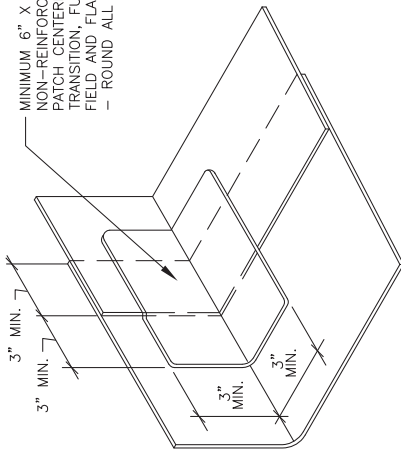

MINIMUM 6" X 6"  
NON-REINFORCED TPO MEMBRANE  
PATCH CENTERED OVER SEAM AT  
TRANSITION, FULLY WELDED TO  
FIELD AND FLASHING MEMBRANE  
— ROUND ALL CORNERS

MINIMUM 6" X 6"  
NON-REINFORCED TPO MEMBRANE  
PATCH CENTERED OVER SEAM AT  
TRANSITION, FULLY WELDED TO  
FIELD AND FLASHING MEMBRANE  
— ROUND ALL CORNERS

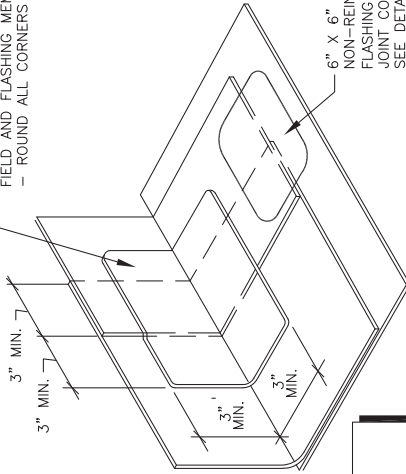

CONDITION 1 — WHEN RUSS IS USED

6" X 6" TPO  
NON-REINFORCED  
FLASHING OR "T"  
JOINT COVER —  
SEE DETAIL  
MHT-UN-105B

CONDITION 2 — WHEN RUSS IS NOT USED

NOTES:

1. DETAIL TO BE USED IN CONJUNCTION WITH STANDARD GUIDE SPECIFICATION CONTAINING REQUIREMENTS FOR NAILERS, INSULATION, ETC.
2. FIELD / WALL TRANSITION PATCHES ARE REQUIRED ON ALL JOBS.

SEAM PATCH AT FIELD / WALL TRANSITION

DETAIL NO.:  
**MHT-UN-105C**  
REVISION DATE: 10/2013

SYSTEMS:  
ALL TPO SYSTEMS

**MULE-HIDE  
PRODUCTS CO., INC.**

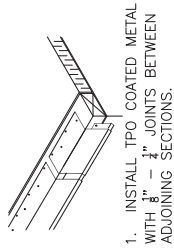

1. INSTALL TPO COATED METAL WITH  $\frac{1}{2}$ " -  $\frac{3}{4}$ " JOINTS BETWEEN ADJOINING SECTIONS.

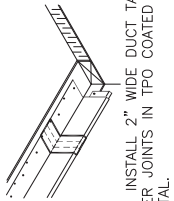

2. INSTALL 2" WIDE DUCT TAPE OVER JOINTS IN TPO COATED METAL.

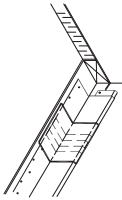

3. HEAT WELD 6" WIDE PIECE OF TPO NON-REINFORCED FLASHING OVER JOINT.

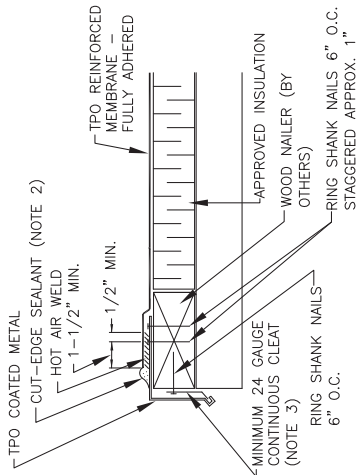

NOTES:

1. FASTENERS USED TO ATTACH TPO COATED METAL MUST PENETRATE WOOD NAILERS A MINIMUM OF 1- $\frac{1}{2}$ " IF  $\frac{3}{8}$ " PLYWOOD IS USED AS THE TOP NAILER. FASTENERS MUST PENETRATE A MINIMUM OF 1- $\frac{3}{4}$ " INTO NAILER BELOW.
2. APPROXIMATELY  $\frac{3}{8}$ " DIAMETER BEAD OF CUT-EDGE SEALANT IS REQUIRED ON CUT EDGES OF TPO REINFORCED MEMBRANE.
3. GAUGE OF CONTINUOUS CLEAT IS DEPENDENT ON THE FASCIA HEIGHT AS SHOWN IN THE CHART BELOW.

MAX. FASCIA HEIGHT	GAUGE OF CONT. CLEAT
4"	24 GAUGE
6"	22 GAUGE
8"	20 GAUGE

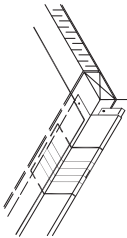

4. POSITION TPO REINFORCED MEMBRANE AND HEAT WELD TO TPO COATED METAL A MINIMUM OF 1- $\frac{1}{2}$ " AS SHOWN TO LEFT.

NOTE:

THIS DETAIL IS ACCEPTABLE FOR USE IN A 20-YEAR WARRANTED SYSTEM

IF SHEETMETAL IS TO BE INCLUDED IN THE WARRANTY, CONTRACTOR MUST USE MULE-HIDE METAL PRODUCTS. REFER TO DETAILS MHT-3120, MHE-3120, MHT-3550, OR MHT-3555

DRIP EDGE  
TPO COATED METAL

SYSTEMS:

FULLY ADHERED

DETAIL NO.:

**MHT-FA-106A**

REVISION DATE: 10/2013

**MULE-HIDE  
PRODUCTS CO., INC.**



NOTES:

1. CLEAN THE EXISTING MEMBRANE (AND METAL IF APPLICABLE) WITH WEATHERED MEMBRANE CLEANER. PRIME THE MEMBRANE USING TAPE PRIMER. ONCE THE PRIMER IS PROPERLY DRIED, THE TPO PRESSURE-SENSITIVE COVER STRIP IS APPLIED AND ROLLED USING A 2" WIDE ROLLER.
2. WOOD NAILER MUST EXTEND PAST TOTAL WIDTH OF METAL FASCIA DECK FLANGE.
3. FASTENERS AND FASTENER PATTERN AS RECOMMENDED BY METAL EDGE MANUFACTURER.
4. DECK FLANGE MUST BE TOTALLY COVERED BY TPO PRESSURE-SENSITIVE COVER STRIP WITH MINIMUM 2" COVERAGE PAST NAIL HEADS.
5. APPLY MULE-HIDE UNIVERSAL SINGLE PLY SEALANT ALONG BOTH EDGES OF TPO COVER TAPE AND ACROSS ENDLAPS.

HEAT COVER STRIP AT SPlice INTERSECTIONS PRIOR TO ROLLING TO CONFORM TO STEP-OFFS

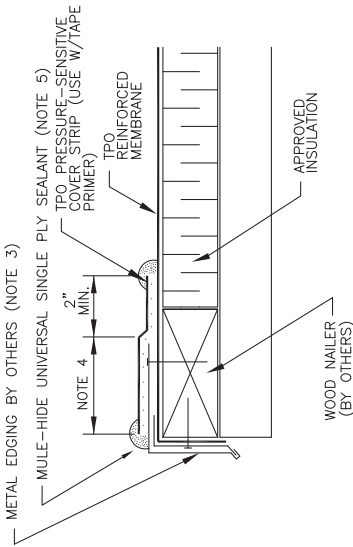

NOTE:  
THIS DETAIL IS ACCEPTABLE FOR USE IN A 20-YEAR WARRANTED SYSTEM  
IF SHEETMETAL IS TO BE INCLUDED IN THE WARRANTY, CONTRACTOR MUST USE MULE-HIDE METAL PRODUCTS. REFER TO DETAILS MHT-3120, MHE-3120, MHT-3550, OR MHT-3555

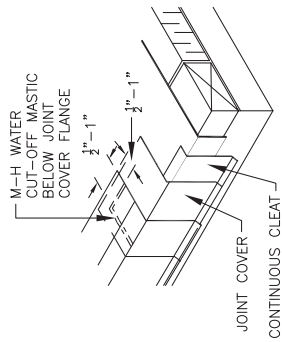

<b>MULE-HIDE PRODUCTS CO., INC.</b>	<b>DRIP EDGE TPO P/S COVER STRIP SYSTEMS:</b>	<b>DETAIL NO.:</b> <b>MHT-UN-106B</b>
	<b>ALL TPO SYSTEMS</b>	REVISION DATE: 10/2013

NOTES:

1. CLEAN THE EXISTING MEMBRANE (AND METAL IF APPLICABLE) WITH WEATHERED MEMBRANE CLEANER. PRIME THE MEMBRANE USING TAPE PRIMER. ONCE THE PRIMER IS PROPERLY DRIED, THE WHITE EPDM CURED COVER STRIP IS APPLIED AND ROLLED USING A 2" WIDE ROLLER.
2. WOOD NAILER MUST EXTEND PAST TOTAL WIDTH OF METAL FASCIA DECK FLANGE.
3. FASTENERS AND FASTENER PATTERN AS RECOMMENDED BY METAL EDGE MANUFACTURER.
4. DECK FLANGE MUST BE TOTALLY COVERED BY WHITE EPDM CURED COVER STRIP WITH MINIMUM 2" COVERAGE PAST NAIL HEADS.
5. APPLY MULE-HIDE UNIVERSAL SINGLE PLY SEALANT ALONG BOTH EDGES OF WHITE EPDM CURED COVER TAPE AND ACROSS END LAPS.

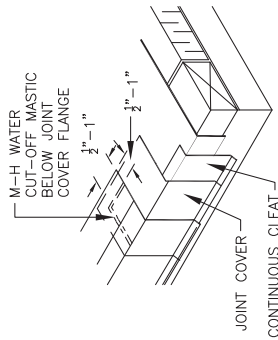
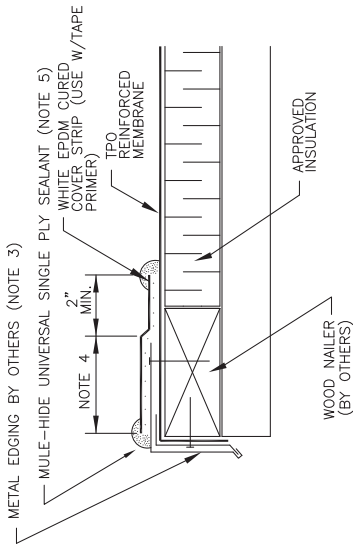

NOTE:

THIS DETAIL IS ACCEPTABLE FOR USE IN A 20-YEAR WARRANTED SYSTEM

IF SHEETMETAL IS TO BE INCLUDED IN THE WARRANTY, CONTRACTOR MUST USE MULE-HIDE METAL PRODUCTS. REFER TO DETAILS: MHT-3120, MHE-3120, MHT-3550, OR MHT-3555

DRIP EDGE  
WHITE EPDM CURED COVER TAPE  
SYSTEMS:

ALL TPO SYSTEMS

DETAIL NO.:

**MHT-UN-106C**

REVISION DATE: 10/2013

**MULE-HIDE  
PRODUCTS CO., INC.**

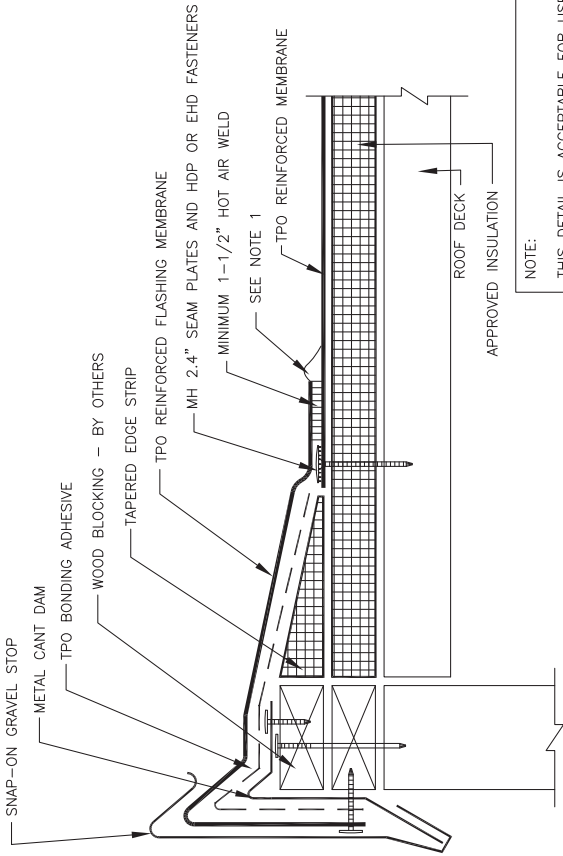

NOTE:

THIS DETAIL IS ACCEPTABLE FOR USE IN A 20-YEAR WARRANTED SYSTEM

NOTES:

1. APPROXIMATELY 1/8" DIAMETER BEAD OF CUT-EDGE SEALANT IS REQUIRED ON CUT EDGES OF TPO REINFORCED MEMBRANE.

IF SHEETMETAL IS TO BE INCLUDED IN THE WARRANTY, CONTRACTOR MUST USE MULE-HIDE METAL PRODUCTS. REFER TO DETAILS MHT-3110A OR MHT-3115A

TAPERED EDGE / GRAVEL STOP

DETAIL NO.:

**MHT-UN-201**

REVISION DATE: 10/2013

SYSTEMS:

ALL TPO SYSTEMS

**MULE-HIDE PRODUCTS CO., INC.**

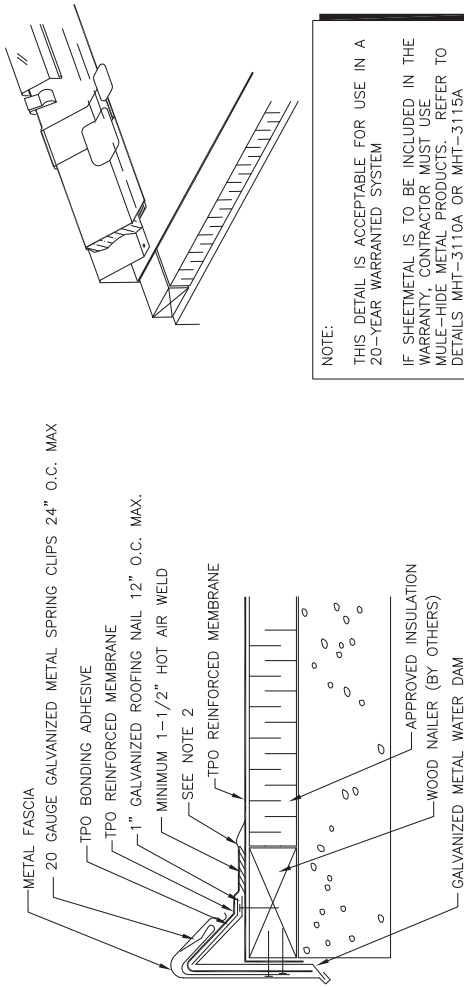

NOTE:  
 THIS DETAIL IS ACCEPTABLE FOR USE IN A 20-YEAR WARRANTED SYSTEM  
 IF SHEETMETAL IS TO BE INCLUDED IN THE WARRANTY, CONTRACTOR MUST USE MULE-HIDE METAL PRODUCTS. REFER TO DETAILS MHT-3110A OR MHT-3115A

NOTES:

1. WOOD NAILER MUST EXTEND PAST TOTAL WIDTH OF DECK FLANGE.
2. APPROXIMATELY 1/8" DIAMETER BEAD OF CUT-EDGE SEALANT IS REQUIRED ON CUT EDGES OF TPO REINFORCED MEMBRANE.

**MULE-HIDE PRODUCTS CO., INC.**

**SNAP-ON FASCIA WITH SPRING CLIPS SYSTEMS:**  
**ALL TPO SYSTEMS**

**DETAIL NO.:**  
**MHT-UN-202A**  
 REVISION DATE: 10/2013

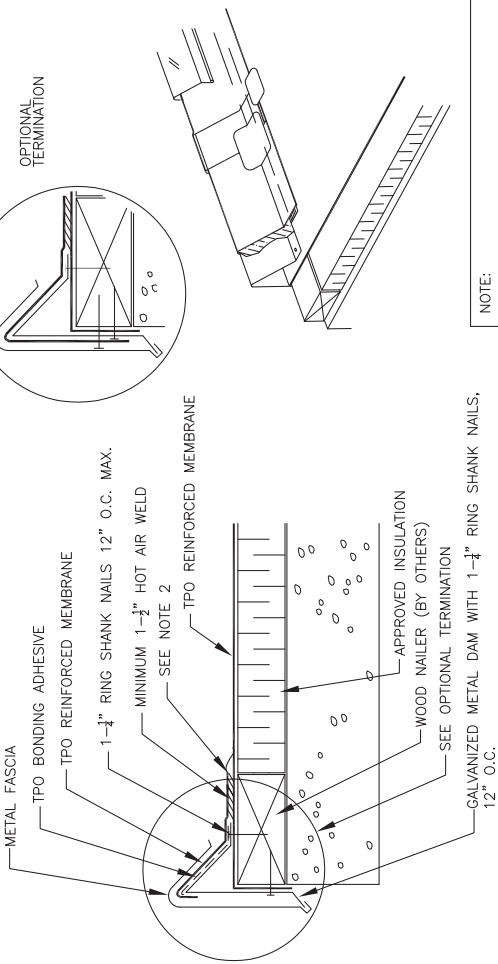

OPTIONAL TERMINATION

**NOTE:**  
 THIS DETAIL IS ACCEPTABLE FOR USE IN A 20-YEAR WARRANTED SYSTEM IF SHEETMETAL IS TO BE INCLUDED IN THE WARRANTY. CONTRACTOR MUST USE MULE-HIDE METAL PRODUCTS. REFER TO DETAILS MHT-3110A OR MHT-3115A

**NOTES:**

1. WOOD NAILER MUST EXTEND PAST TOTAL WIDTH OF DECK FLANGE.
2. APPROXIMATELY 1/8" DIAMETER BEAD OF CUT-EDGE SEALANT IS REQUIRED ON CUT EDGES OF TPO REINFORCED MEMBRANE.

**SNAP-ON FASCIA SYSTEMS:**  
 ALL TPO SYSTEMS

**DETAIL NO.:**  
**MHT-UN-202B**  
 REVISION DATE: 10/2013

**MULE-HIDE PRODUCTS CO., INC.**

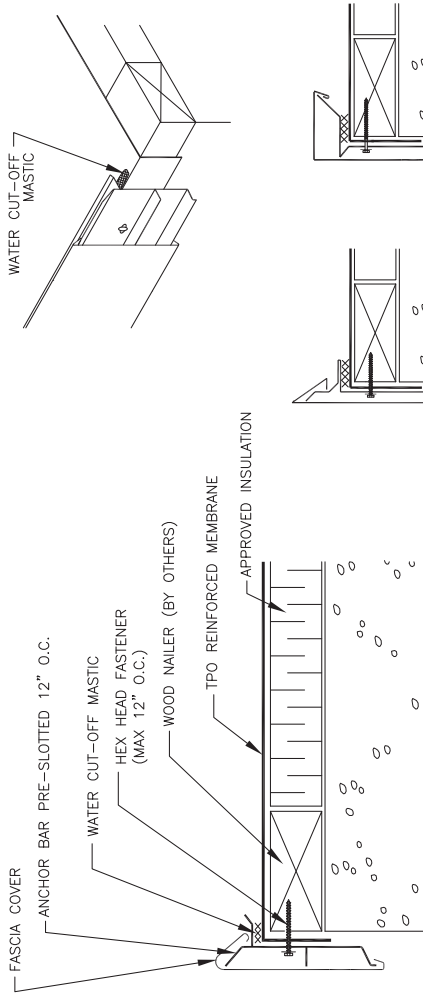

NOTES:

1. IF INCIDENTAL/PERIODIC PONDED WATER IS EXPECTED, THE FASCIA SYSTEM MUST BE ELEVATED AND SCUPPERS PROVIDED FOR DRAINAGE.
2. CONTACT METAL-ERA (800-558-2162) FOR INSTALLATION INSTRUCTION MANUAL FOR STEP-BY-STEP PROCEDURES AND FOR THE VARIOUS PRODUCT FEATURES AVAILABLE.
3. ANCHOR-TITE FASCIA SYSTEM IS A PATENTED EDGE SYSTEM MANUFACTURED BY METAL-ERA INC.
4. ANCHOR-TITE FASCIA SYSTEM IS ELIGIBLE FOR A SHEET METAL WARRANTY FROM MULE-HIDE.

ANCHOR BAR OPTIONS

NOTE:  
THIS DETAIL IS ACCEPTABLE FOR USE IN A  
20-YEAR WARRANTED SYSTEM

<p><b>MULE-HIDE PRODUCTS CO., INC.</b></p>	<p><b>ANCHOR-TITE FASCIA SYSTEM BY METAL-ERA, INC. SYSTEMS: ALL TPO SYSTEMS</b></p>
<p>DETAIL NO.: <b>MHT-UN-204</b> REVISION DATE: 10/2013</p>	

**NOTE:**

IF SHEETMETAL IS TO BE INCLUDED IN THE WARRANTY, CONTRACTOR MUST USE MULE-HIDE METAL PRODUCTS. REFER TO DETAILS MHSM-3500, MHSM-3510, OR MHSM-3511.

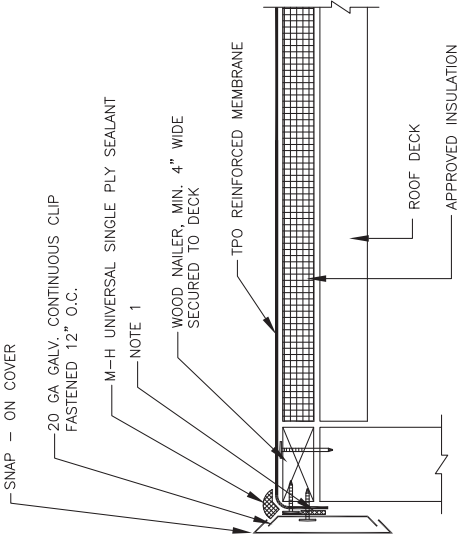

**NOTES:**

1. INSTALL A BEAD OF APPROVED SEALANT BETWEEN THE CLIP AND THE TPO REINFORCED MEMBRANE.
2. SNAP ON COVER SHALL BE A MINIMUM THICKNESS OF: STEEL - 24 GAUGE ALUMINUM - .032 INCHES

**NOTE:**

THIS DETAIL IS ACCEPTABLE FOR USE IN A 20-YEAR WARRANTED SYSTEM

**FASCIA / DRIP EDGE SYSTEM**

**MULE-HIDE PRODUCTS CO., INC.**

**DETAIL NO.:**

**MHT-UN-205**

**SYSTEMS:**

**ALL TPO SYSTEMS**

REVISION DATE: 10/2013

**NOTE:**

IF SHEETMETAL IS TO BE INCLUDED IN THE WARRANTY, CONTRACTOR MUST USE MULE-HIDE METAL PRODUCTS. REFER TO DETAIL MHSM-2091.

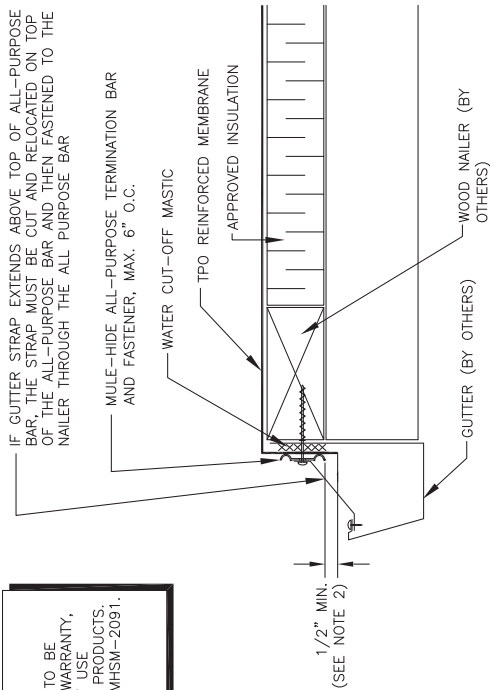

**NOTES:**

1. FASTENING OF ALL-PURPOSE BAR MUST PROVIDE CONSTANT COMPRESSION ON WATER CUT-OFF MASTIC.
2. ALL PURPOSE BAR IS INSTALLED WITH "BUMPS" DOWN, FACING THE MEMBRANE.
3. ALLOW MEMBRANE SHEET TO EXTEND 1/2" MINIMUM BELOW ALL-PURPOSE BAR TO ENSURE FASTENER PENETRATION THROUGH SCRIM REINFORCEMENT.

**NOTE:**

THIS DETAIL IS ACCEPTABLE FOR USE IN A 20-YEAR WARRANTED SYSTEM

<b>MULE-HIDE PRODUCTS CO., INC.</b>	<b>ALL - PURPOSE BAR EDGE TERMINATION SYSTEMS:</b>	<b>DETAIL NO.:</b> <b>MHT-UN-206</b>
	<b>ALL TPO SYSTEMS</b>	REVISION DATE: 10/2013



NOTE:  
 IF SHEETMETAL IS TO BE INCLUDED IN THE WARRANTY, CONTRACTOR MUST USE MULE-HIDE METAL PRODUCTS. REFER TO DETAIL MHT-3130.

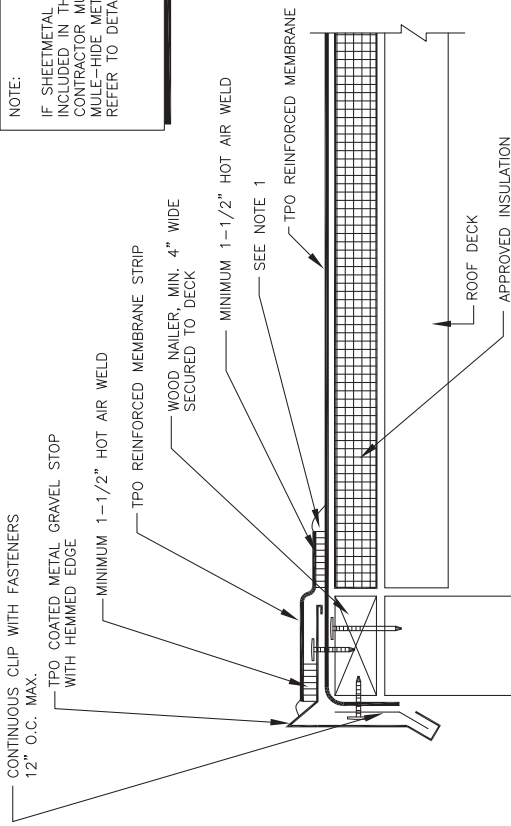

NOTE:  
 THIS DETAIL IS ACCEPTABLE FOR USE IN A 20-YEAR WARRANTED SYSTEM

- NOTES:
1. APPROXIMATELY 1/8" DIAMETER BEAD OF CUT-EDGE SEALANT IS REQUIRED ON CUT EDGES OF TPO REINFORCED MEMBRANE.
  2. SEE DETAIL MHT-UN-213 FOR INSTRUCTIONS TO SEAL JOINTS IN GRAVEL STOP.

<b>MULE-HIDE          PRODUCTS CO., INC.</b>	<b>GRAVEL STOP          TPO COATED METAL          SYSTEMS:</b>	<b>DETAIL NO.:</b> <b>MHT-UN-211</b>
	<b>ALL TPO SYSTEMS</b>	REVISION DATE: 10/2013

NOTE:  
 IF SHEETMETAL IS TO BE INCLUDED IN THE WARRANTY, CONTRACTOR MUST USE MULE-HIDE METAL PRODUCTS. REFER TO DETAIL MHT-3130.

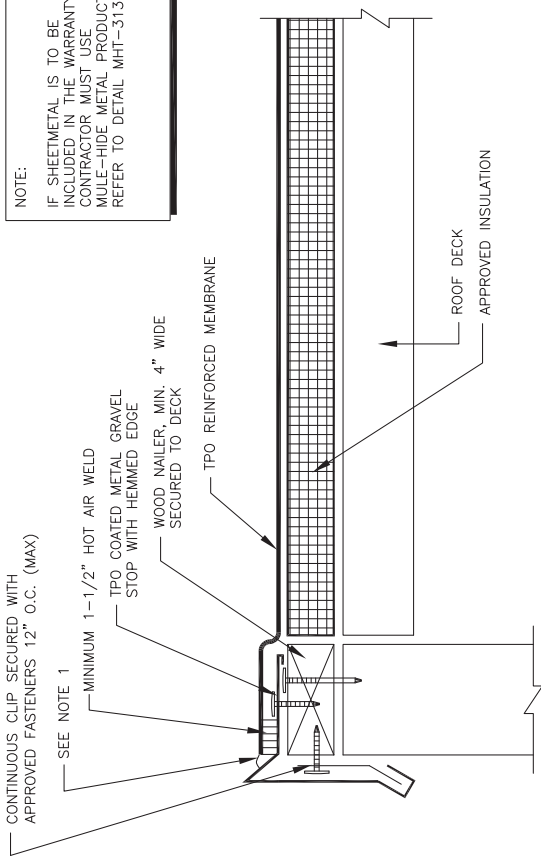

NOTE:  
 THIS DETAIL IS NOT ACCEPTABLE FOR USE IN A 20-YEAR WARRANTED SYSTEM OR FOR EXTENDED WIND SPEED COVERAGE

- NOTES:
1. APPROXIMATELY 1/8" DIAMETER BEAD OF CUT-EDGE SEALANT IS REQUIRED ON CUT EDGES OF TPO REINFORCED MEMBRANE.

<b>MULE-HIDE          PRODUCTS CO., INC.</b>	<b>GRAVEL STOP          TPO COATED METAL          SYSTEMS:</b>	<b>DETAIL NO.:</b> <b>MHT-UN-212</b>
	<b>ALL TPO SYSTEMS</b>	REVISION DATE: 10/2013

NOTE:  
 IF SHEETMETAL IS TO BE INCLUDED IN THE WARRANTY, CONTRACTOR MUST USE MULE-HIDE METAL PRODUCTS. REFER TO DETAIL MHT-3130.

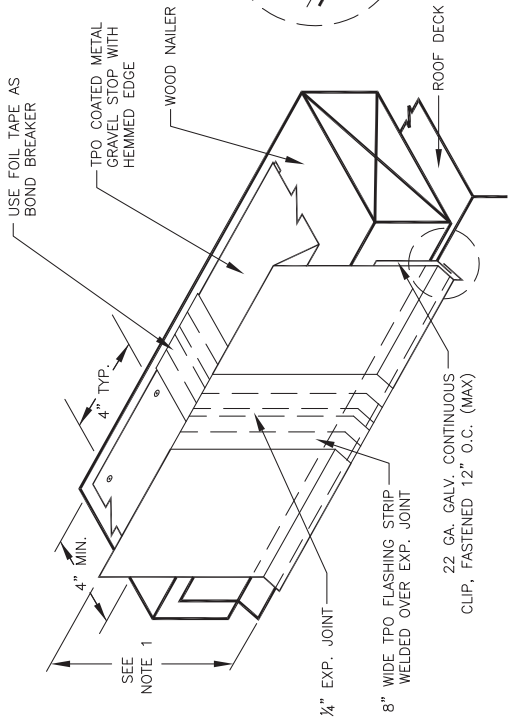
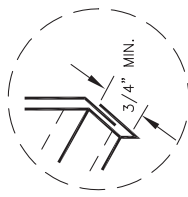

NOTE:  
 USING THIS DETAIL IN CONJUNCTION WITH DETAIL MHT-UN-212 WILL NOT BE ACCEPTABLE FOR USE IN A 20-YEAR WARRANTED SYSTEM.  
 USING THIS DETAIL IN CONJUNCTION WITH DETAIL MHT-UN-211 WILL BE ACCEPTABLE FOR USE IN A 20-YEAR WARRANTED SYSTEM.

- NOTES:
1. MAXIMUM FACE DIMENSION SHOULD BE 5" TO PREVENT DISTORTION FROM "OIL CANNING". IF SURFACE DISTORTION IS ACCEPTABLE, FACE DIMENSION MAY BE INCREASED TO 8".
  2. FOR FASCIAS GREATER THAN 8", INSTALL IN TWO SECTIONS.

GRAVEL STOP JOINT DETAIL  
 TPO COATED METAL  
 SYSTEMS:

**MULE-HIDE  
 PRODUCTS CO., INC.**

DETAIL NO.:  
**MHT-UN-213**  
 REVISION DATE: 10/2013

ALL TPO SYSTEMS

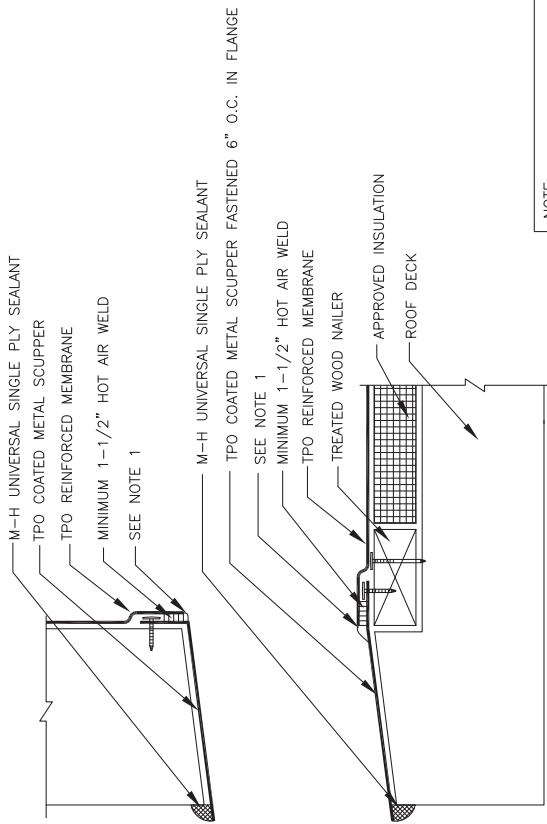

NOTE:  
 THIS DETAIL IS NOT ACCEPTABLE FOR USE  
 IN A 20-YEAR WARRANTED SYSTEM. FOR  
 A 20-YEAR WARRANTY USE DETAIL  
 MHT-UN-220B

NOTES:

1. APPROXIMATELY 1/8" DIAMETER BEAD OF CUT-EDGE SEALANT IS REQUIRED ON CUT EDGES OF TPO REINFORCED MEMBRANE.

<b>MULE-HIDE          PRODUCTS CO., INC.</b>	<b>THROUGH-WALL SCUPPER          TPO COATED METAL          SYSTEMS:</b>	<b>DETAIL NO.:</b> <b>MHT-UN-220A</b>
	<b>ALL TPO SYSTEMS</b>	REVISION DATE: 10/2013

NOTES:

1. WOOD NAILER MUST EXTEND PAST TOTAL WIDTH OF DECK FLANGE.
2. INSTALL WALL FLASHING PRIOR TO SCUPPER INSTALLATION.
3. DISCONTINUE FASTENING PLATES AT SCUPPER OPENING AS SHOWN.
4. METAL SCUPPER BOX MUST HAVE CONTINUOUS SIDES; METAL FLANGE MUST BE CONTINUOUS WITH ROUNDED CORNERS.
5. WATER CUT-OFF MASTIC UNDER SCUPPER FLANGE MUST BE UNDER CONSTANT COMPRESSION.
6. MINIMUM 1- $\frac{1}{2}$ " HOT AIR WELD FROM NAIL HEAD.
7. MULE-HIDE UNIVERSAL SINGLE PLY SEALANT IS REQUIRED AT FLASHING EDGE ON SCUPPER EDGE. MULE-HIDE TAPE PRIMER MUST BE USED TO PREPARE SURFACES PRIOR TO APPLYING UNIVERSAL SINGLE PLY SEALANT.

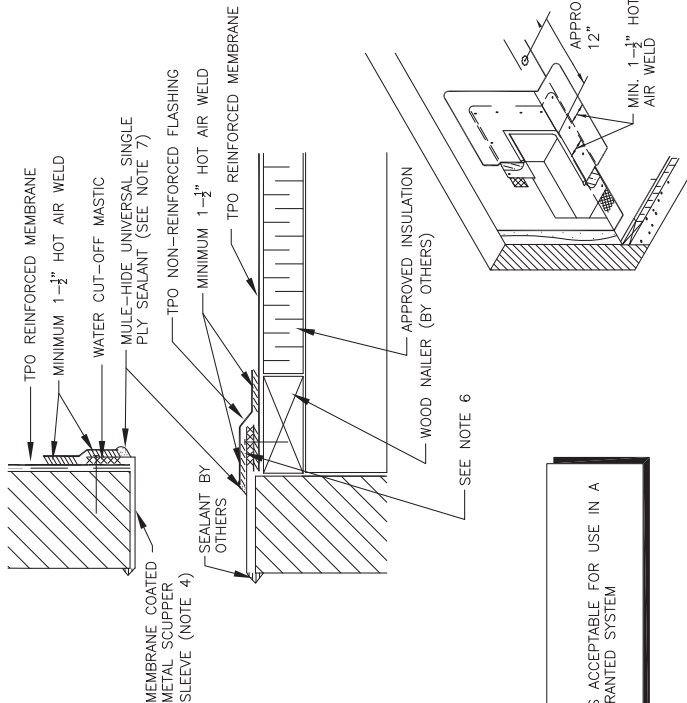

NOTE:  
THIS DETAIL IS ACCEPTABLE FOR USE IN A  
20-YEAR WARRANTED SYSTEM

<b>MULE-HIDE PRODUCTS CO., INC.</b>	<b>THROUGH-WALL SCUPPER TPO COATED METAL SYSTEMS:</b>	<b>DETAIL NO.:</b> <b>MHT-UN-220B</b>
	<b>ALL TPO SYSTEMS</b>	REVISION DATE: 10/2013

NOTES:

1. WOOD NAILER MUST EXTEND PAST TOTAL WIDTH OF DECK FLANGE.
2. INSTALL WALL FLASHING PRIOR TO SCUPPER INSTALLATION.
3. DISCONTINUE FASTENING PLATES AT SCUPPER OPENING AS SHOWN.
4. METAL SCUPPER BOX MUST HAVE CONTINUOUS SIDES; METAL FLANGE MUST BE CONTINUOUS WITH ROUNDED CORNERS.
5. CLEAN METAL SCUPPER FLANGE WITH MULE-HIDE WEATHERED MEMBRANE CLEANER TO REMOVE ANY OILS BEFORE APPLYING MULE-HIDE TAPE PRIMER.
6. WATER CUT-OFF MASTIC UNDER SCUPPER FLANGE MUST BE UNDER CONSTANT COMPRESSION.
7. MINIMUM 2" SPLICE FROM NAIL HEAD.
8. MULE-HIDE UNIVERSAL SINGLE PLY SEALANT IS REQUIRED AT FLASHING EDGE ON SCUPPER EDGE. MULE-HIDE TAPE PRIMER MUST BE USED TO PREPARE SURFACES PRIOR TO APPLYING MULE-HIDE UNIVERSAL SINGLE PLY SEALANT.

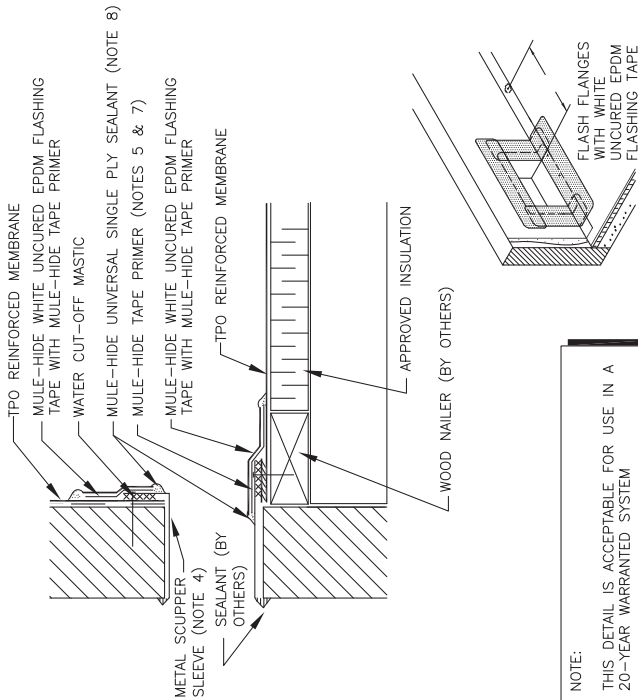

NOTE:

THIS DETAIL IS ACCEPTABLE FOR USE IN A 20-YEAR WARRANTED SYSTEM

NEW METAL THROUGH-WALL SCUPPER WITH WHITE UNCURED EPDM

SYSTEMS:

ALL TPO SYSTEMS

DETAIL NO.:

**MHT-UN-220C**

REVISION DATE: 10/2013

**MULE-HIDE PRODUCTS CO., INC.**

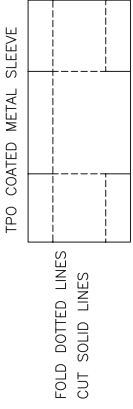
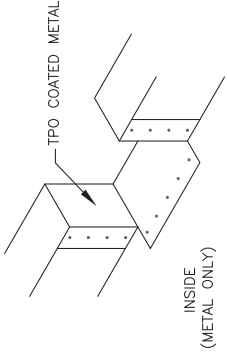

FLASH WALL WITH TPO  
MEMBRANE PRIOR TO  
INSTALLING SCUPPER  
SLEEVE. RESET COPING  
AFTER INSTALLATION

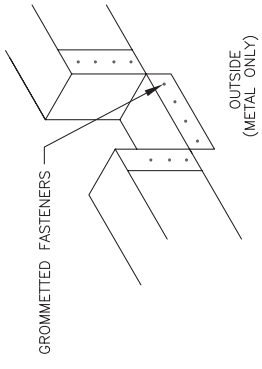
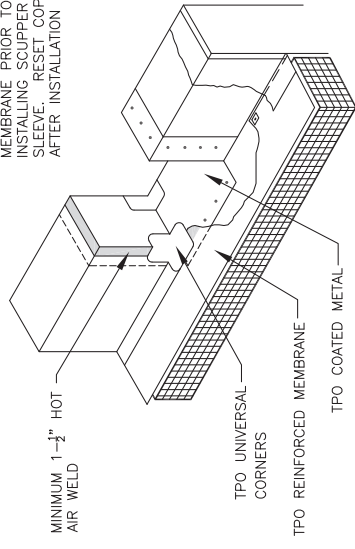

NOTE:  
THIS DETAIL IS ACCEPTABLE FOR USE IN A  
20-YEAR WARRANTED SYSTEM

THROUGH-WALL OPEN SCUPPER  
TPO COATED METAL  
SYSTEMS:  
ALL TPO SYSTEMS

DETAIL NO.:  
**MHT-UN-221**  
REVISION DATE: 10/2013

**MULE-HIDE  
PRODUCTS CO., INC.**

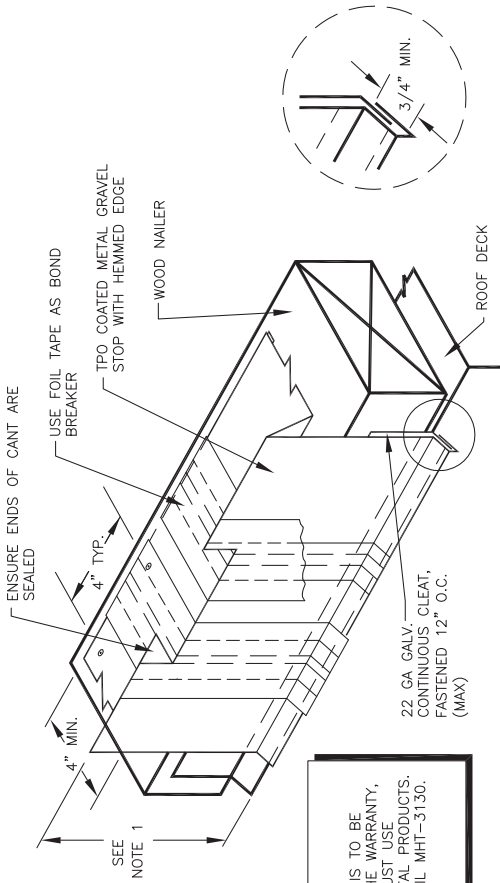

**NOTE:**  
 IF SHEETMETAL IS TO BE INCLUDED IN THE WARRANTY, CONTRACTOR MUST USE MULE-HIDE METAL PRODUCTS. REFER TO DETAIL MHT-3130.

**NOTE:**  
 USING THIS DETAIL IN CONJUNCTION WITH DETAIL MHT-UN-212 WILL NOT BE ACCEPTABLE FOR USE IN A 20-YEAR WARRANTED SYSTEM.  
 USING THIS DETAIL IN CONJUNCTION WITH DETAIL MHT-UN-211 WILL BE ACCEPTABLE FOR USE IN A 20-YEAR WARRANTED SYSTEM.

- NOTES:**
1. MAXIMUM FACE DIMENSION SHOULD BE 5" TO PREVENT DISTORTION FROM "OIL CANNING." IF SURFACE DISTORTION IS ACCEPTABLE, FACE DIMENSION MAY BE INCREASED TO 8".
  2. FOR FASCIAS GREATER THAN 8", INSTALL IN TWO SECTIONS.

<b>MULE-HIDE          PRODUCTS CO., INC.</b>	<b>GRAVEL STOP SCUPPER          TPO COATED METAL          SYSTEMS:</b> ALL TPO SYSTEMS	<b>DETAIL NO.:</b> <b>MHT-UN-222</b> REVISION DATE: 10/2013



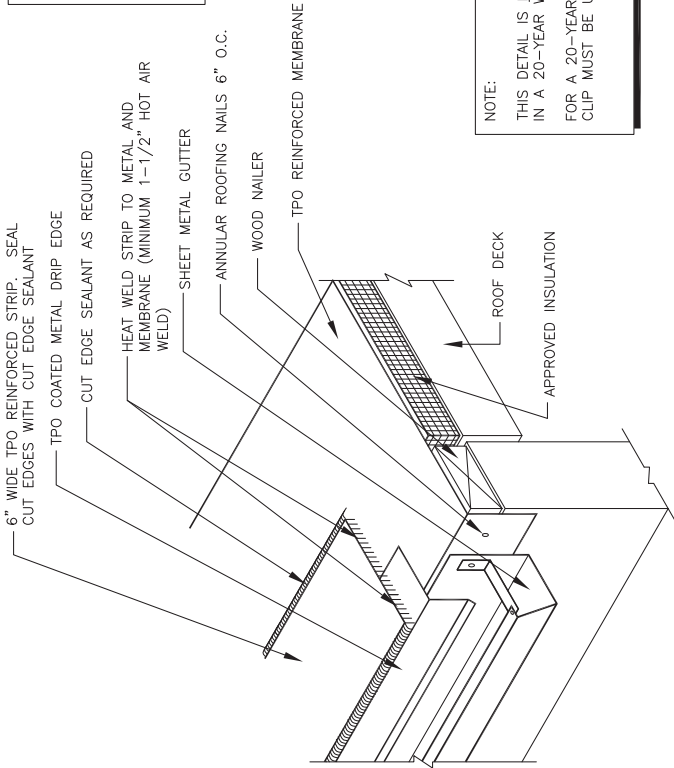

NOTE:  
 IF SHEETMETAL IS TO BE INCLUDED IN THE WARRANTY, CONTRACTOR MUST USE MULE-HIDE METAL PRODUCTS. REFER TO DETAILS MHSM-2091 AND MHT-3120.

NOTE:  
 THIS DETAIL IS NOT ACCEPTABLE FOR USE IN A 20-YEAR WARRANTED SYSTEM. FOR A 20-YEAR WARRANTY, A CONTINUOUS CLIP MUST BE USED WITH THE DRIP EDGE.

DETAIL NO.:  
**MHT-UN-232**  
 REVISION DATE: 10/2013

GUTTER DRIP EDGE  
 TPO COATED METAL  
 SYSTEMS:  
 ALL TPO SYSTEMS

**MULE-HIDE  
 PRODUCTS CO., INC.**

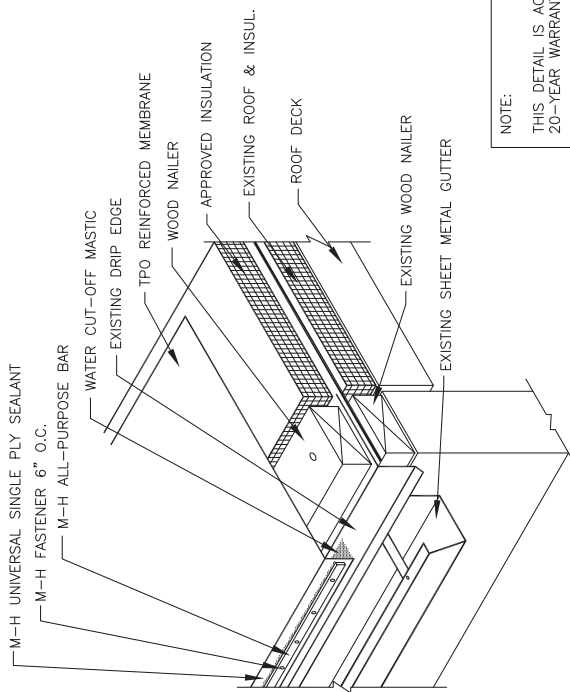

NOTE:

THIS DETAIL IS ACCEPTABLE FOR USE IN A  
20-YEAR WARRANTED SYSTEM

**MULE-HIDE  
PRODUCTS CO., INC.**

GUTTER / TERMINATION BAR  
RECOVER  
SYSTEMS:

ALL RECOVER TPO SYSTEMS

DETAIL NO.:

**MHT-UN-234**

REVISION DATE: 10/2013

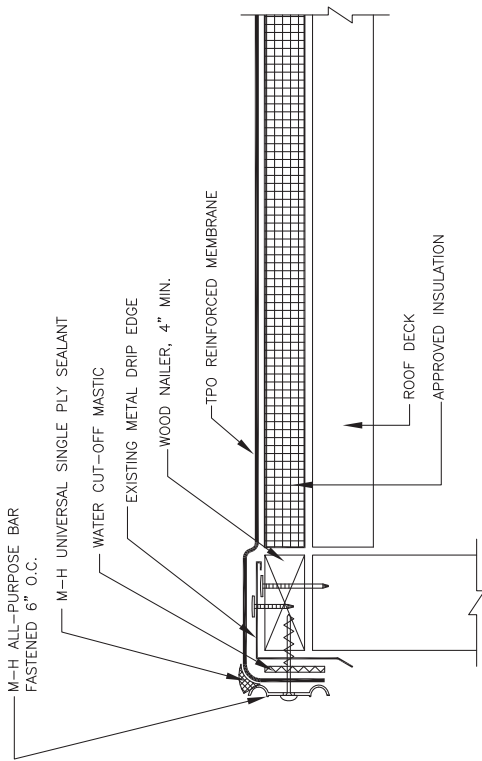

M-H ALL-PURPOSE BAR  
FASTENED 6" O.C.

M-H UNIVERSAL SINGLE PLY SEALANT

WATER CUT-OFF MASTIC

EXISTING METAL DRIP EDGE

WOOD NAILER, 4" MIN.

TPO REINFORCED MEMBRANE

ROOF DECK

APPROVED INSULATION

NOTE:

THIS DETAIL IS ACCEPTABLE FOR USE IN A  
20-YEAR WARRANTED SYSTEM

EDGE TERMINATION  
ALL-PURPOSE BAR  
SYSTEMS:

ALL RECOVER TPO SYSTEMS

DETAIL NO.:

**MHT-UN-240**

REVISION DATE: 10/2013

**MULE-HIDE  
PRODUCTS CO., INC.**

NOTES:

1. AN OVERLAP OF 1½" WILL BE REQUIRED BETWEEN SECTIONS OF MEMBRANE COATED METAL. A BEAD OF SEALANT IS REQUIRED IN EACH OVERLAP.
2. A WOOD NAILER IS REQUIRED. TOP OF WOOD NAILER TO BE FLUSH WITH TOP OF INSULATION.
3. DRIP EDGE MUST BE FASTENED 6" ON CENTER.
4. A CLEAT MUST BE INSTALLED ON ALL DRIP EDGE WITH A FACE OF 4" OR GREATER. CLEAT MUST BE FASTENED 6" ON CENTER. ALL FASTENERS ON THE CLEAT MUST BE WITHIN 1-¾" OF THE BOTTOM EDGE.
5. USE STAINLESS STEEL FASTENERS WHEN ATTACHING INTO ACQ TREATED WOOD.

NOTE:

THIS DETAIL QUALIFIES TO BE INCLUDED IN ANY MULE-HIDE LABOR AND MATERIAL WARRANTY ONLY IF THE FORMED DRIP EDGE AND CLEATS ARE MANUFACTURED BY MULE-HIDE.

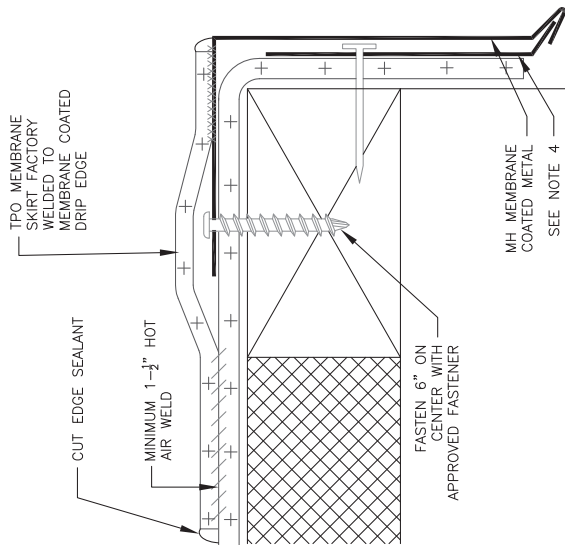

<p><b>MULE-HIDE PRODUCTS CO., INC.</b></p>	<p><b>MULE-HIDE PREMANUFACTURED MEMBRANE COATED DRIP EDGE SYSTEMS:</b></p> <p><b>ALL TPO SYSTEMS</b></p>	<p><b>DETAIL NO.:</b> <b>MHT-3120</b></p> <p>REVISION DATE: 10/2013</p>

NOTES:

1. FASTEN THE T-EDGE BASE TO THE WOOD NAILER (ENOUGH TO HOLD IN PLACE) WITH GALVANIZED NAILS. BE SURE TO INSTALL A SPLICE PLATE BEHIND EACH SECTION OF T-EDGE.
2. ATTACH THE MEMBRANE COATED METAL HOOK STRIP TO THE T-EDGE BASE AND FASTEN IT 6" ON CENTER WITH APPROVED FASTENERS. BE SURE THAT THIS ROW OF FASTENERS ALSO PENETRATES THROUGH THE T-EDGE BASE. HOOK STRIPS MUST OVERLAP EACH OTHER BY 1" ALLOW FOR A 3/8" GAP BETWEEN INDIVIDUAL SECTIONS OF THE T-EDGE BASE. STAGGER THE SEAMS BETWEEN THE BASE AND THE HOOK STRIP 12" MINIMUM.
3. A CONTINUOUS BEAD OF SEALANT IS REQUIRED BETWEEN THE MEMBRANE COATED METAL HOOK STRIP AND THE T-EDGE BASE.
4. A CLEAT IS REQUIRED ON FACES THAT ARE 4" OR GREATER IN SIZE. ALL FASTENERS ON THE CLEAT MUST BE WITHIN 1-3/4" OF THE BOTTOM EDGE.
5. WELD REINFORCED TPO STRIPPING MATERIAL TO THE HOOK STRIP AND FIELD MEMBRANE.
6. USE STAINLESS STEEL FASTENERS WHEN ATTACHING INTO ACQ TREATED WOOD.

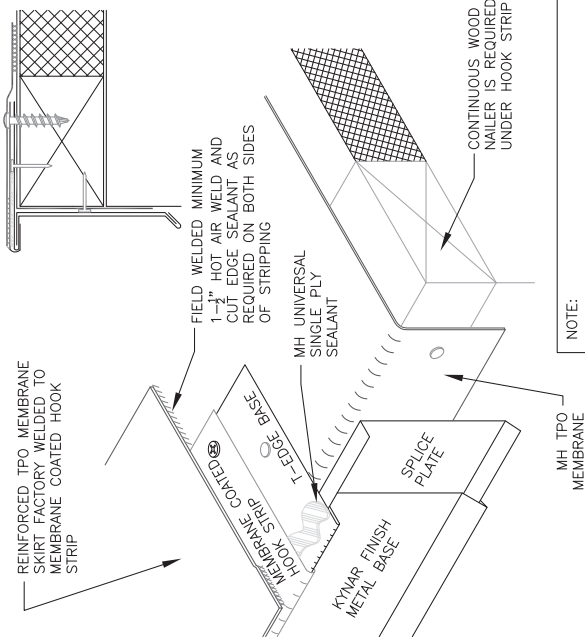

NOTE:

THIS DETAIL QUALIFIES TO BE INCLUDED IN ANY MULE-HIDE LABOR AND MATERIAL WARRANTY

MULE-HIDE PREMANUFACTURED T-EDGE METAL EDGE DETAIL SYSTEMS:

ALL TPO SYSTEMS

DETAIL NO.:

**MHT-3550**

REVISION DATE: 10/2013

**MULE-HIDE PRODUCTS CO., INC.**

NOTES:

1. FASTEN THE T-EDGE BASE TO THE WOOD NAILER (ENOUGH TO HOLD IN PLACE) WITH GALVANIZED NAILS. BE SURE TO INSTALL A SPLICE PLATE BEHIND EACH SECTION OF T-EDGE.
2. ATTACH THE MEMBRANE COATED METAL HOOK STRIP TO THE T-EDGE BASE AND FASTEN IT 6" ON CENTER WITH APPROVED FASTENERS. BE SURE THAT THIS ROW OF FASTENERS ALSO PENETRATES THROUGH THE T-EDGE BASE. HOOK STRIPS MUST OVERLAP EACH OTHER BY 1". ALLOW FOR A 8" GAP BETWEEN INDIVIDUAL SECTIONS OF THE T-EDGE BASE. STAGGER THE SEAMS BETWEEN THE BASE AND THE HOOK STRIP 12" MINIMUM.
3. A CONTINUOUS BEAD OF SEALANT IS REQUIRED BETWEEN THE MEMBRANE COATED METAL HOOK STRIP AND THE T-EDGE BASE.
4. A CLEAT IS REQUIRED ON FACES THAT ARE 4" OR GREATER IN SIZE. ALL FASTENERS ON THE CLEAT MUST BE WITHIN 1-3/4" OF THE BOTTOM EDGE.
5. WELD REINFORCED TPO STRIPPING MATERIAL TO THE HOOK STRIP AND FIELD MEMBRANE.
6. USE STAINLESS STEEL FASTENERS WHEN ATTACHING INTO ACQ TREATED WOOD.

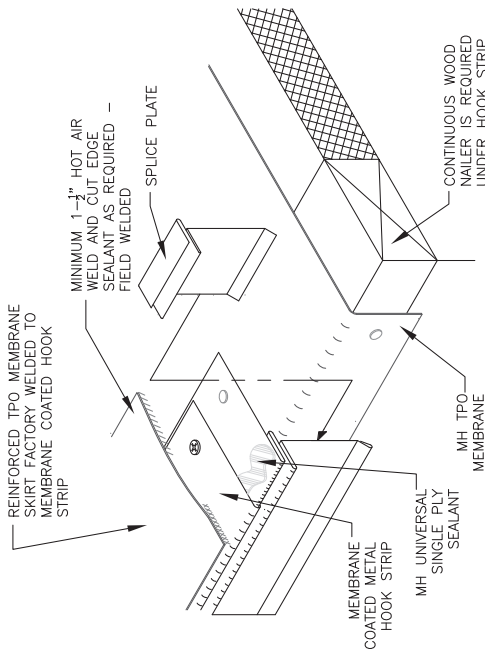

NOTE:

THIS DETAIL QUALIFIES TO BE INCLUDED IN ANY MULE-HIDE LABOR AND MATERIAL WARRANTY

MULE-HIDE PREMANUFACTURED T-EDGE PLUS METAL EDGE DETAIL SYSTEMS:

ALL TPO SYSTEMS

DETAIL NO.:

**MHT-3555**

REVISION DATE: 10/2013

**MULE-HIDE PRODUCTS CO., INC.**

NOTES:

1. THE USE OF THIS DETAIL IS NOT TO EXCEED A 2" PER 12" SLOPE.
2. A WOOD NAILER IS REQUIRED. TOP OF WOOD NAILER IS TO BE FLUSH WITH TOP OF INSULATION. BE SURE THAT THE WOOD NAILER EXTENDS AT LEAST ½" BEYOND THE HORIZONTAL EDGE OF THE SNAP-ON BASE.
3. THE FASTENERS USED TO ATTACH THE BASE TO WOOD NAILERS, AND THE MEMBRANE TO THE FACE OF THE NAILERS, MUST BE SPACED NO GREATER THAN 6" ON CENTER.
4. ALLOW FOR ⅛" EXPANSION GAP BETWEEN 10' LENGTHS OF SNAP-ON BASE. OVERLAP THE SNAP-ON COVERS 2" BETWEEN 10' LENGTHS.
5. WHEN INSTALLING THIS DETAIL WITH A 6" OR GREATER VERTICAL SURFACE, ADDITIONAL MECHANICAL ATTACHMENT IS REQUIRED ON THE SNAP-ON BASE. THE ADDITIONAL FASTENERS MUST BE WITHIN 1'-3" OF THE BOTTOM EDGE.
6. MEMBRANE SHOULD EXTEND BEYOND WOOD NAILER BY MINIMUM 1"
7. MAXIMUM MEMBRANE STRIPPING THICKNESS ON THIS DETAIL IS AS FOLLOWS:
  - TPO - 45 MIL
8. USE STAINLESS STEEL FASTENERS WHEN ATTACHING INTO ACO TREATED WOOD.

NOTE:

THIS DETAIL QUALIFIES TO BE INCLUDED IN ANY MULE-HIDE LABOR AND MATERIAL WARRANTY

NOTE:

THIS DETAIL IS ACCEPTABLE FOR USE IN ALL EXTENDED WARRANTIES AND HIGH WIND ZONES.

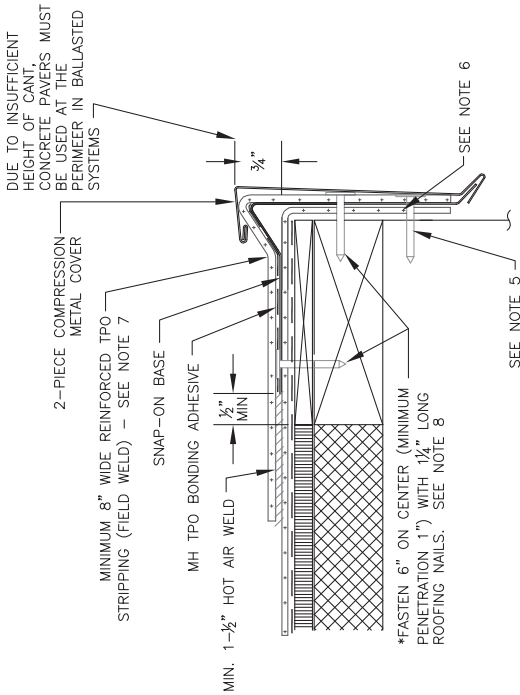

<p><b>MULE-HIDE PRODUCTS CO., INC.</b></p>	<p><b>MULE-HIDE PREMANUFACTURED 2-PIECE COMPRESSION EDGE DETAIL SYSTEMS:</b></p>	<p><b>DETAIL NO.:</b> <b>MHT-3110</b></p>
	<p><b>ALL TPO SYSTEMS</b></p>	<p>REVISION DATE: 01/2013</p>

**NOTE:**  
THIS DETAIL QUALIFIES TO BE INCLUDED IN ANY MULE-HIDE LABOR AND MATERIAL WARRANTY

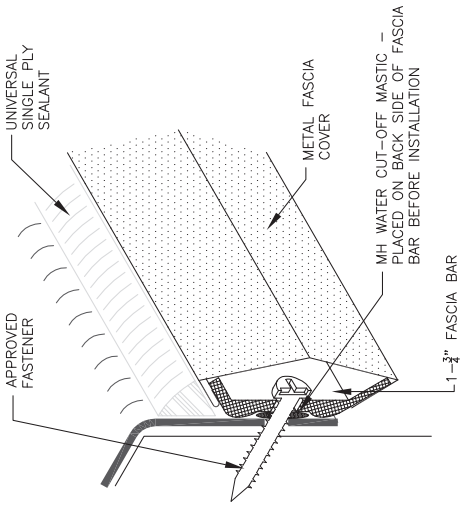
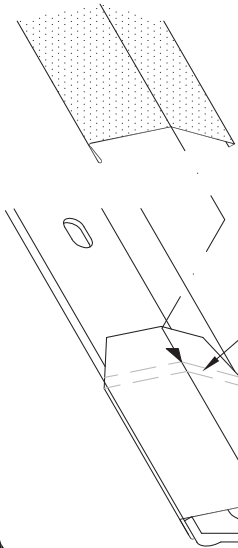

- NOTES:**
1. JOINTS ON THE FASCIA BAR MUST BE OFFSET BY A MINIMUM OF 12" FROM THE JOINTS IN THE FASCIA COVER.
  2. THE FASCIA BAR MUST BE FASTENED 6" ON CENTER.
  3. USE STAINLESS STEEL FASTENERS WHEN ATTACHING INTO A/CQ TREATED WOOD.

<b>MULE-HIDE PRODUCTS CO., INC.</b>	<b>MULE-HIDE PREMANUFACTURED 1-3/4" METAL FASCIA SYSTEM SYSTEMS:</b> <b>ALL SYSTEMS</b>	<b>DETAIL NO.:</b> <b>MHSM-3500</b> REVISION DATE: 01/2013



**NOTE:**

IF SHEETMETAL IS TO BE INCLUDED IN THE WARRANTY, CONTRACTOR MUST USE MULE-HIDE METAL PRODUCTS. REFER TO DETAILS MHSM-6050, MHSM-6052, MHSM-6054A&B, OR MHSM-6056..

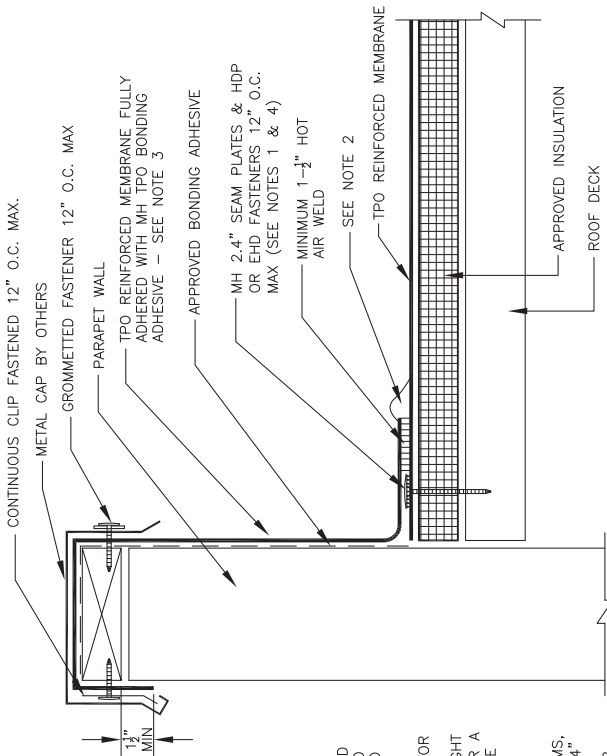

**NOTES:**

1. POSITION SEAM PLATES 1/2" TO 1" FROM EDGE OF DECK MEMBRANE.
2. APPROXIMATELY 1/8" DIAMETER BEAD OF CUT-EDGE SEALANT IS REQUIRED ON CUT EDGES OF TPO REINFORCED MEMBRANE.
3. WHEN COUNTERFLASHING IS USED FOR TERMINATION, BONDING ADHESIVE IS NOT REQUIRED. WHEN FLASHING HEIGHT IS 12" OR LESS. WHEN COPING OR A TERMINATION BAR IS USED, ADHESIVE MAY BE ELIMINATED WHEN FLASHING HEIGHT IS 18" OR LESS.
4. ON MECHANICALLY FASTENED SYSTEMS, MH HDP OR EHD FASTENERS AND 2.4" SEAM PLATES ARE REQUIRED AS A MINIMUM. CONTACT MULE-HIDE FOR TPO REINFORCED MEMBRANE FASTENING CRITERIA AND PROPER FASTENERS FOR EACH DECK TYPE.

PARAPET WALL  
METAL COPING CAP  
SYSTEMS:

ALL TPO SYSTEMS

DETAIL NO.:

**MHT-UN-301**

REVISION DATE: 10/2013

**MULE-HIDE  
PRODUCTS CO., INC.**

**NOTE:**  
 IF SHEETMETAL IS TO BE INCLUDED IN THE WARRANTY, CONTRACTOR MUST USE MULE-HIDE METAL PRODUCTS. REFER TO DETAILS WHSM-6050, WHSM-6052, WHSM-6054A & B, OR WHSM-6056..

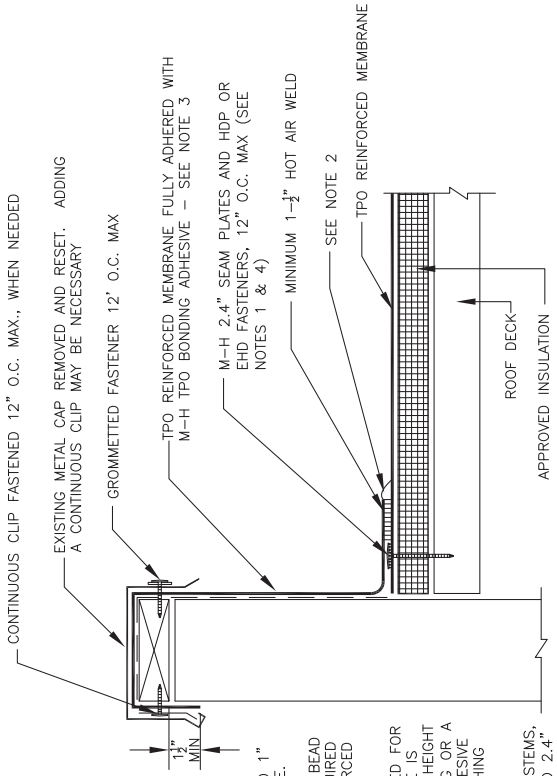

**NOTES:**

1. POSITION SEAM PLATES 1/2" TO 1" FROM EDGE OF DECK MEMBRANE.
2. APPROXIMATELY 1/8" DIAMETER BEAD OF CUT-EDGE SEALANT IS REQUIRED ON CUT EDGES OF TPO REINFORCED MEMBRANE.
3. WHEN COUNTERFLASHING IS USED FOR TERMINATION, BONDING ADHESIVE IS NOT REQUIRED WHEN FLASHING HEIGHT IS 12" OR LESS. WHEN COPING OR A TERMINATION BAR IS USED, ADHESIVE MAY BE ELIMINATED WHEN FLASHING HEIGHT IS 18" OR LESS.
4. ON MECHANICALLY FASTENED SYSTEMS, MH HDP OR EHD FASTENERS AND 2.4" SEAM PLATES ARE REQUIRED AS A MINIMUM. CONTACT MULE-HIDE FOR TPO REINFORCED MEMBRANE FASTENING CRITERIA AND PROPER FASTENERS FOR EACH DECK TYPE.

<b>MULE-HIDE          PRODUCTS CO., INC.</b>	<b>PARAPET WALL          EXISTING COPING CAP          SYSTEMS:          ALL TPO SYSTEMS</b>
<b>DETAIL NO.:          MHT-UN-302</b> REVISION DATE: 10/2013	

**NOTE:**

IF SHEETMETAL IS TO BE INCLUDED IN THE WARRANTY, CONTRACTOR MUST USE MULE-HIDE METAL PRODUCTS. REFER TO DETAILS MHSM-6050, MHSM-6052, MHSM-6054A & B, OR MHSM-6056..

**NOTES:**

1. POSITION SEAM PLATES 1/2" TO 1" FROM EDGE OF DECK MEMBRANE.
2. APPROXIMATELY 1/8" DIAMETER BEAD OF CUT-EDGE SEALANT IS REQUIRED ON CUT EDGES OF TPO REINFORCED MEMBRANE.
3. WHEN COUNTERFLASHING IS USED FOR TERMINATION, BONDING ADHESIVE IS NOT REQUIRED WHEN FLASHING HEIGHT IS 12" OR LESS. WHEN COPING OR A TERMINATION BAR IS USED, ADHESIVE MAY BE ELIMINATED WHEN FLASHING HEIGHT IS 18" OR LESS.
4. ON MECHANICALLY FASTENED SYSTEMS, MH HDP OR EHD FASTENERS AND 2.4" SEAM PLATES ARE REQUIRED AS A MINIMUM. CONTACT MULE-HIDE FOR TPO REINFORCED MEMBRANE FASTENING CRITERIA AND PROPER FASTENERS FOR EACH DECK TYPE.

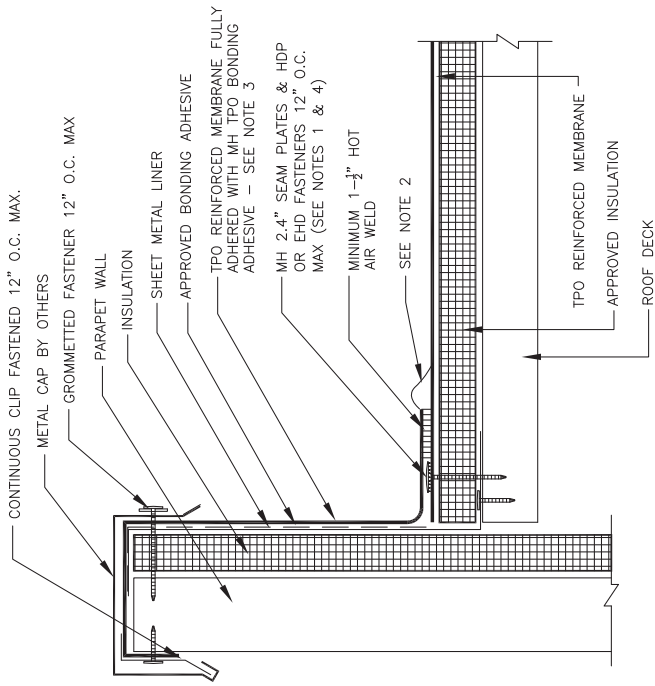

**INSULATED PARAPET WALL WITH METAL COPING CAP SYSTEMS:**

**ALL TPO SYSTEMS**

**DETAIL NO.:**  
**MHT-UN-303**

REVISION DATE: 10/2013

**MULE-HIDE PRODUCTS CO., INC.**

NOTES:

1. POSITION SEAM PLATES 1/2" TO 1" FROM EDGE OF DECK MEMBRANE.
2. APPROXIMATELY 1/8" DIAMETER BEAD OF CUT-EDGE SEALANT IS REQUIRED ON CUT EDGES OF TPO REINFORCED MEMBRANE.
3. WHEN COUNTERFLASHING IS USED FOR TERMINATION, BONDING ADHESIVE IS NOT REQUIRED WHEN FLASHING HEIGHT IS 12" OR LESS. WHEN COPING OR A TERMINATION BAR IS USED, ADHESIVE MAY BE ELIMINATED WHEN FLASHING HEIGHT IS 18" OR LESS.
4. ON MECHANICALLY FASTENED SYSTEMS, MH HDP OR EHD FASTENERS AND 2.4" SEAM PLATES ARE REQUIRED AS A MINIMUM. CONTACT MULE-HIDE FOR TPO REINFORCED MEMBRANE FASTENING CRITERIA AND PROPER FASTENERS FOR EACH DECK TYPE.

CREASE MEMBRANE AT ANGLE  
CHANGE TO LIMIT BRIDGING TO  
3/4" MAX

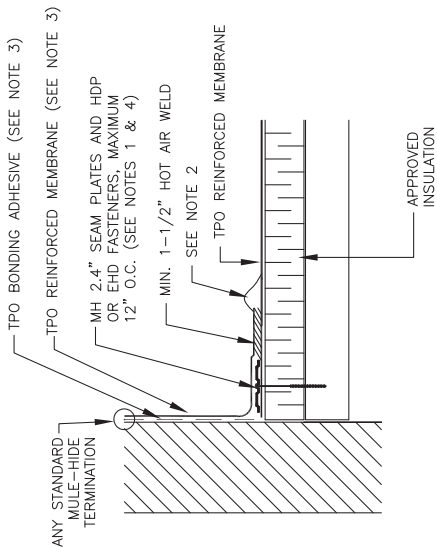

BASE ATTACHMENT  
WITH PLATES AND FASTENERS  
SYSTEMS:

ALL TPO SYSTEMS

DETAIL NO.:

**MHT-UN-305A**

REVISION DATE: 10/2013

**MULE-HIDE  
PRODUCTS CO., INC.**

CREASE MEMBRANE AT ANGLE  
CHANGE TO LIMIT BRIDGING TO  
3/4" MAX

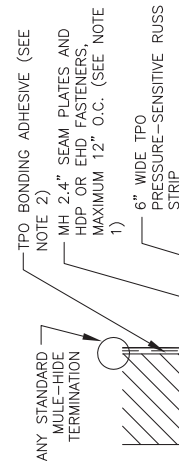
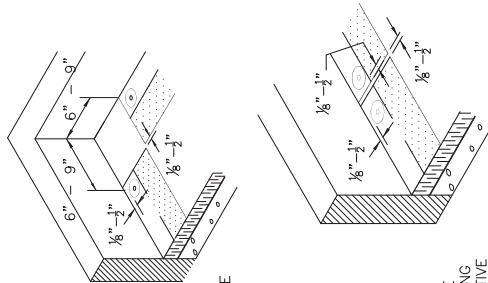

- NOTES:
- ON MECHANICALLY FASTENED SYSTEMS, MH HDP OR EHD FASTENERS AND 2.4" SEAM PLATES ARE REQUIRED AS A MINIMUM. CONTACT MULE-HIDE FOR TPO REINFORCED MEMBRANE FASTENING CRITERIA AND PROPER FASTENERS FOR EACH DECK TYPE.
  - WHEN COUNTERFLASHING IS USED FOR TERMINATION, BONDING ADHESIVE IS NOT REQUIRED WHEN FLASHING HEIGHT IS 12" OR LESS. WHEN COPING OR TERMINATION BAR IS USED, ADHESIVE MAY BE ELIMINATED WHEN FLASHING HEIGHT IS 18" OR LESS.
  - RUSS PRODUCTS CANNOT BE USED ON FLEECEBACK OR SELF ADHERING MEMBRANES.

MH TAPE PRIMER MUST BE APPLIED TO BACK SIDE OF TPO REINFORCED MEMBRANE PRIOR TO ADHERING TPO REINFORCED MEMBRANE TO PRESSURE-SENSITIVE RUSS STRIP

BASE ATTACHMENT  
USING 6" RUSS

SYSTEMS:  
ALL TPO SYSTEMS  
EXCEPT FLEECEBACK AND SELF ADHERING

DETAIL NO.:

**MHT-UN-305B**

REVISION DATE: 10/2013

**MULE-HIDE  
PRODUCTS CO., INC.**

NOTES:

1. WHEN USING MULE-HIDE ALL-PURPOSE BAR UNDER COUNTERFLASHING TO TERMINATE WALL FLASHING, TPO BONDING ADHESIVE MAY BE ELIMINATED WHEN FLASHING HEIGHT IS 18" OR LESS.
2. FLASHING SHALL BE A MINIMUM OF 8" HIGH WHEN POSSIBLE. REUSE OF EXISTING COUNTERFLASHING IS ACCEPTABLE IF ABOVE MAXIMUM FLOOD LEVEL AND METAL IS IN GOOD CONDITION. FUNCTIONAL WEEP HOLES MUST NOT BE BLOCKED.
3. APPROXIMATELY 1/8" DIAMETER BEAD OF CUT-EDGE SEALANT IS REQUIRED ON CUT EDGES OF TPO REINFORCED MEMBRANE.

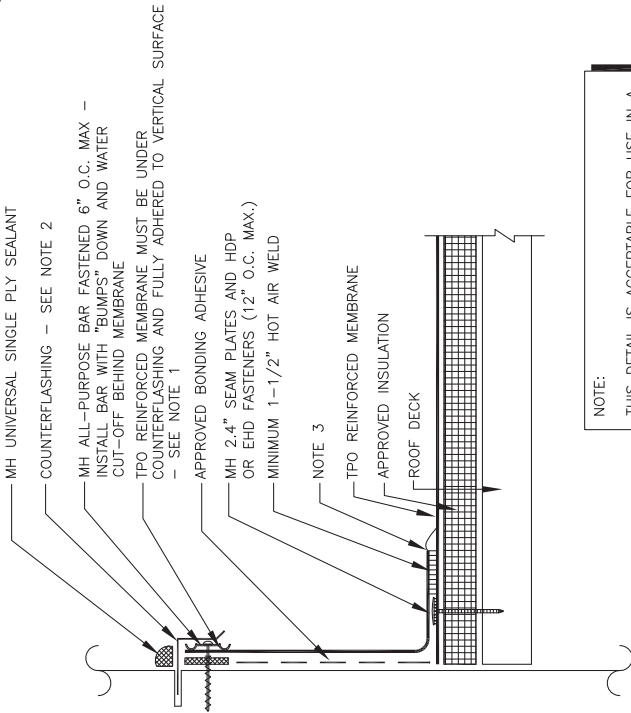

NOTE:  
THIS DETAIL IS ACCEPTABLE FOR USE IN A 20-YEAR WARRANTED SYSTEM

NOTE:  
IF SHEETMETAL IS TO BE INCLUDED IN THE WARRANTY, CONTRACTOR MUST USE MULE-HIDE METAL PRODUCTS. REFER TO DETAILS MHSM-6130, MHSM-6145, OR MHSM-6146.

DETAIL NO.:  
**MHT-UN-310**  
REVISION DATE: 10/2013

WALL FLASHING WITH COUNTERFLASHING SYSTEMS:  
ALL TPO SYSTEMS

**MULE-HIDE PRODUCTS CO., INC.**

**NOTE:**

THIS DETAIL IS NOT ACCEPTABLE FOR USE IN A 20-YEAR WARRANTED SYSTEM

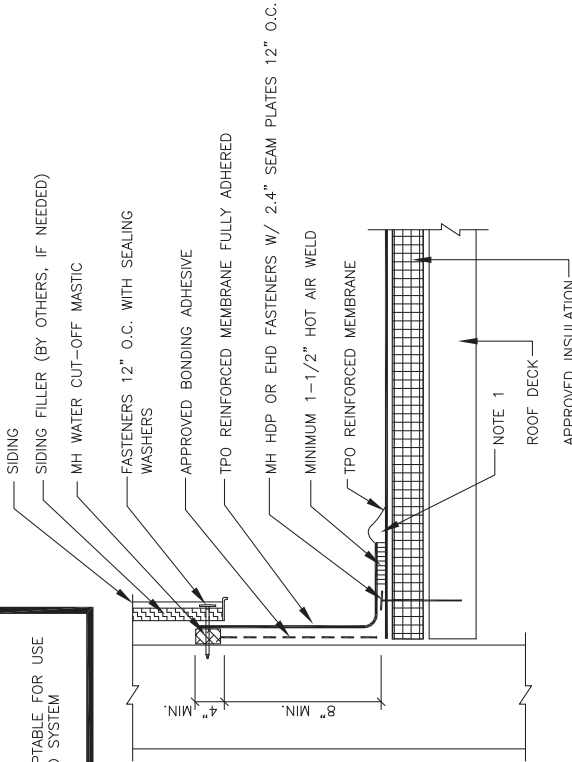

**NOTES:**

1. APPROXIMATELY  $\frac{1}{8}$ " DIAMETER BEAD OF CUT-EDGE SEALANT IS REQUIRED ON CUT EDGES OF TPO REINFORCED MEMBRANE.

**BASE FLASHING  
AT SIDING  
SYSTEMS:  
ALL TPO SYSTEMS**

**DETAIL NO.:**  
**MHT-UN-311**  
REVISION DATE: 10/2013

**MULE-HIDE  
PRODUCTS CO., INC.**

NOTES:

1. WHEN USING MULE-HIDE ALL-PURPOSE BAR TO TERMINATE WALL FLASHING, TPO BONDING ADHESIVE MAY BE ELIMINATED WHEN FLASHING HEIGHT IS 18" OR LESS.
2. FLASHING HEIGHT SHALL BE A MINIMUM OF 8" HIGH WHERE POSSIBLE. IF REMOVING COUNTERFLASHING DO NOT BLOCK OR COVER EXISTING WEEP HOLES. TERMINATION OF THE FLASHING MUST BE BELOW EXISTING WEEP HOLES.
3. ALL PURPOSE BAR FASTENED 6" ON CENTER IN 10' SECTIONS WITH  $\frac{1}{4}$ " GAP BETWEEN SECTIONS. ALL PURPOSE BAR IS TO BE INSTALLED WITH "BUMPS" FACING WALL. A FASTENER MUST BE LOCATED WITHIN 2" OF ENDS OF AP BAR. DO NOT BEND AP BAR AROUND INSIDE OR OUTSIDE CORNERS.
4. APPROXIMATELY 1/8" DIAMETER BEAD OF CUT-EDGE SEALANT IS REQUIRED ON CUT EDGES OF TPO REINFORCED MEMBRANE.

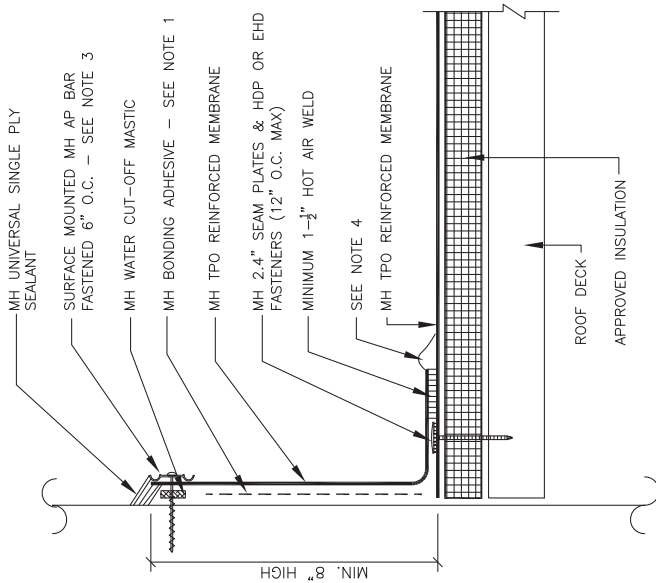

WALL FLASHING  
WITH ALL-PURPOSE BAR  
SYSTEMS:

ALL TPO SYSTEMS

DETAIL NO.:  
**MHT-UN-312**  
REVISION DATE: 10/2013

**MULE-HIDE  
PRODUCTS CO., INC.**



NOTES:

1. POSITION SEAM PLATES 1/2" TO 1" FROM EDGE OF DECK MEMBRANE.
2. APPROXIMATELY 1/8" DIAMETER BEAD OF CUT-EDGE SEALANT IS REQUIRED ON CUT EDGES OF TPO REINFORCED MEMBRANE.

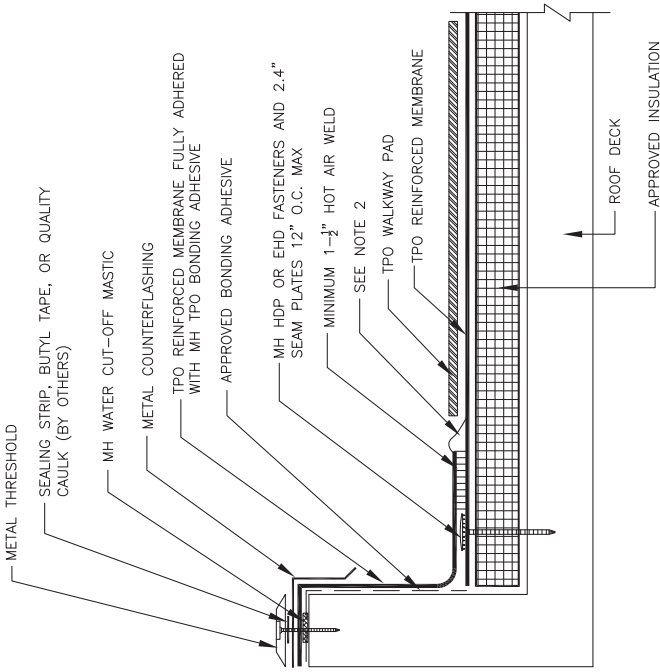

DOOR THRESHOLD FLASHING

SYSTEMS:

ALL TPO SYSTEMS

DETAIL NO.:

**MHT-UN-321**

REVISION DATE: 10/2013

**MULE-HIDE  
PRODUCTS CO., INC.**

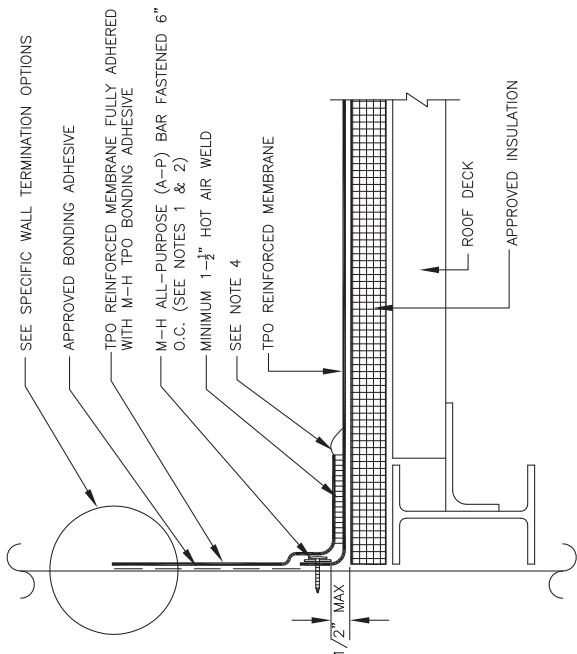

NOTES:

1. USE ONLY WHEN IT IS NOT POSSIBLE TO FASTEN HORIZONTALLY AT BASE OF PARAPET. M-H 2.4" SEAM PLATES MAY BE INSTALLED VERTICALLY AS AN OPTION TO USING THE ALL-PURPOSE BAR. PLATES MUST NOT EXCEED 12" O.C. BOTTOM OF AP BAR OR 2.4" PLATES MUST BE WITHIN 1/2" OF ANGLE CHANGE.
2. WHEN AP BAR IS USED IN LIEU OF 2.4" SEAM PLATES AND HDP OR EHD FASTENERS, THE "BUMPS" ARE INSTALLED UP.
3. WALL FASTENERS MUST ACHIEVE MINIMUM PULLOUT RESISTANCE OF 250 LBS.
4. APPROXIMATELY 1/8" DIAMETER BEAD OF CUT-EDGE SEALANT IS REQUIRED ON CUT EDGES OF TPO REINFORCED MEMBRANE.
5. ALL EXISTING FLASHINGS AND CANTS MUST BE REMOVED DOWN TO THE SUBSTRATE.

BASE ATTACHMENT  
ALL-PURPOSE BAR  
SYSTEMS:  
ALL TPO SYSTEMS

DETAIL NO.:  
**MHT-UN-330**  
REVISION DATE: 11/2014

**MULE-HIDE  
PRODUCTS CO., INC.**

CREASE MEMBRANE AT ANGLE  
CHANGE TO LIMIT BRIDGING TO  
3/4" MAX

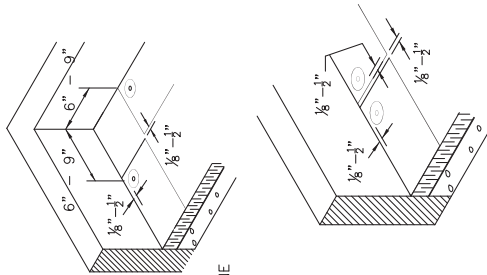

TPO SELF ADHERING MEMBRANE

ANY STANDARD  
MULE-HIDE  
TERMINATION

MH 2.4" SEAM PLATES AND  
HDP OR EHD FASTENERS,  
MAXIMUM 12" O.C. (SEE NOTE  
1)

6" WIDE STRIP OF STANDARD  
REINFORCED TPO-C MEMBRANE

TPO SELF ADHERING MEMBRANE

APPROVED INSULATION

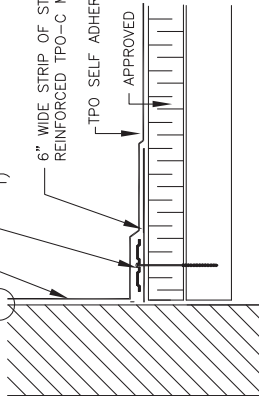

NOTES:

1. CONTACT MULE-HIDE FOR FASTENING CRITERIA AND PROPER FASTENERS FOR EACH DECK TYPE.
2. RUSS PRODUCTS CANNOT BE USED ON FLEECEBACK OR SELF ADHERING MEMBRANES.

MH TPO PRIMER IS NOT NEEDED TO PREPARE THE 6" STRIP OF STANDARD REINFORCED TPO-C MEMBRANE. HOWEVER, THE 6" STRIP OF STANDARD REINFORCED TPO-C MEMBRANE MUST BE CLEAN AND DRY.

**BASE ATTACHMENT**  
**USING 6" STANDARD TPO-C MEMBRANE**  
**SYSTEMS:**  
**TPO SELF ADHERING**  
**SYSTEMS ONLY**

**MULE-HIDE**  
**PRODUCTS CO., INC.**

**DETAIL NO.:**  
**MHT-FA-305C**

REVISION DATE: 3/2014

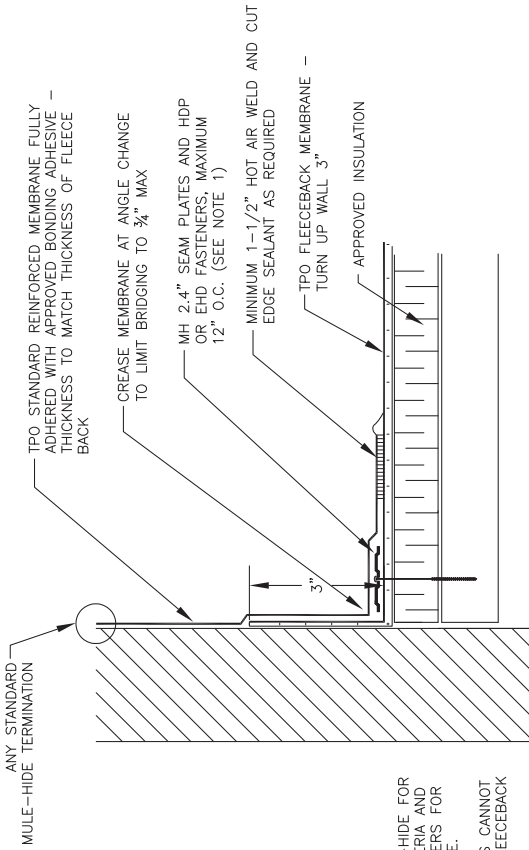

NOTES:

1. CONTACT MULE-HIDE FOR FASTENING CRITERIA AND PROPER FASTENERS FOR EACH DECK TYPE.
2. RUSS PRODUCTS CANNOT BE USED ON FLEECEBACK MEMBRANES.

BASE ATTACHMENT

SYSTEMS:  
TPO FLEECE BACK  
SYSTEMS ONLY

DETAIL NO.:

**MHT-FA-305D**

REVISION DATE: 05/2016

**MULE-HIDE  
PRODUCTS CO., INC.**

NOTES:

1. CONTACT MULE-HIDE FOR FASTENING CRITERIA AND PROPER FASTENERS FOR EACH DECK TYPE.
2. RUSS PRODUCTS CANNOT BE USED ON FLEECEBACK MEMBRANES.

ANY STANDARD MULE-HIDE TERMINATION AFTER FLEECE HAS BEEN REMOVED FROM BACK OF MEMBRANE AT TOP OF FLASHING

APPLY ONE COAT OF APPROVED BONDING ADHESIVE TO FLEECE AND ALLOW TO DRY THEN APPLY BONDING ADHESIVE TO FLEECE AND SUBSTRATE AS A CONTACT ADHESIVE APPLICATION TO LIMIT BRIDGING TO 3/4" MAX

MH 2.4" SEAM PLATES AND HDP OR EHD FASTENERS, MAXIMUM 12" O.C. (SEE NOTE 1)

9" WIDE STRIP OF FLEECEBACK MEMBRANE INSTALLED FLEECE SIDE UP

TPO FLEECEBACK MEMBRANE

APPROVED INSULATION

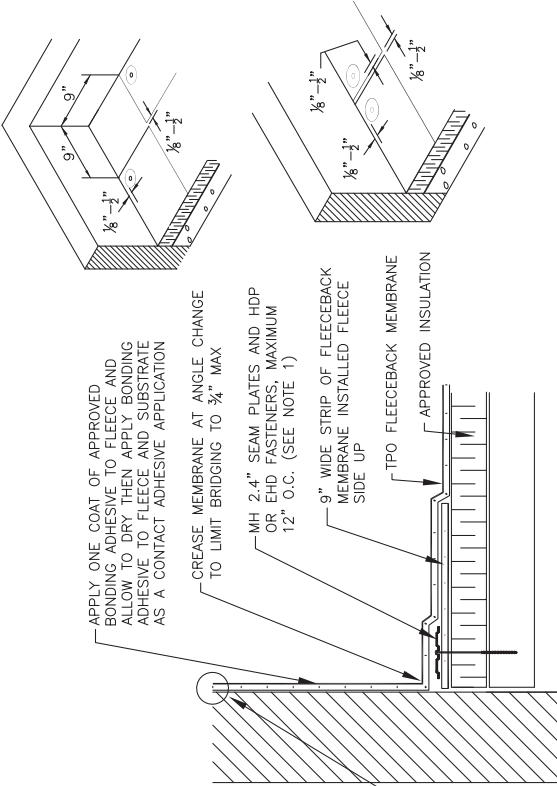

MINIMUM OF 2 BEADS MUST BE APPLIED TO TOP OF 9" FLEECEBACK STRIP TO ENSURE PROPER ADHESION OF FIELD MEMBRANE

BASE ATTACHMENT  
USING INVERTED 9" FLEECE BACK  
SYSTEMS:  
TPO FLEECE BACK  
SYSTEMS ONLY

DETAIL NO.:  
**MHT-FA-305E**

REVISION DATE: 05/2016

**MULE-HIDE  
PRODUCTS CO., INC.**

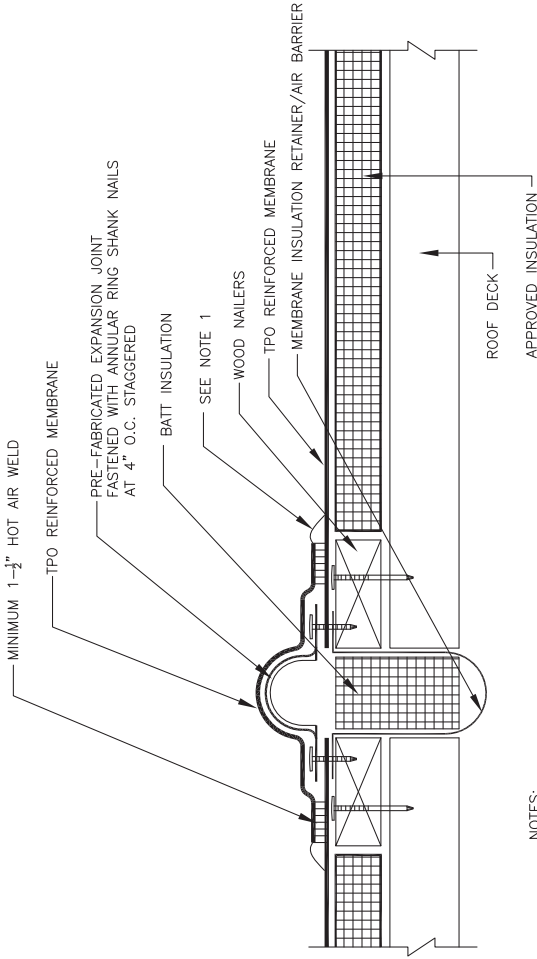

NOTES:

1. APPROXIMATELY 1/8" DIAMETER BEAD OF CUT-EDGE SEALANT IS REQUIRED ON CUT EDGES OF TPO REINFORCED MEMBRANE.

EXPANSION JOINT DETAIL

SYSTEMS:  
ALL TPO SYSTEMS

DETAIL NO.:  
**MHT-UN-401**  
REVISION DATE: 10/2013

**MULE-HIDE  
PRODUCTS CO., INC.**

NOTES:

1. POSITION SEAM PLATES 1/2" TO 1" FROM EDGE OF DECK MEMBRANE.
2. APPROXIMATELY 1/8" DIAMETER BEAD OF CUT-EDGE SEALANT IS REQUIRED ON CUT EDGES OF TPO REINFORCED MEMBRANE.

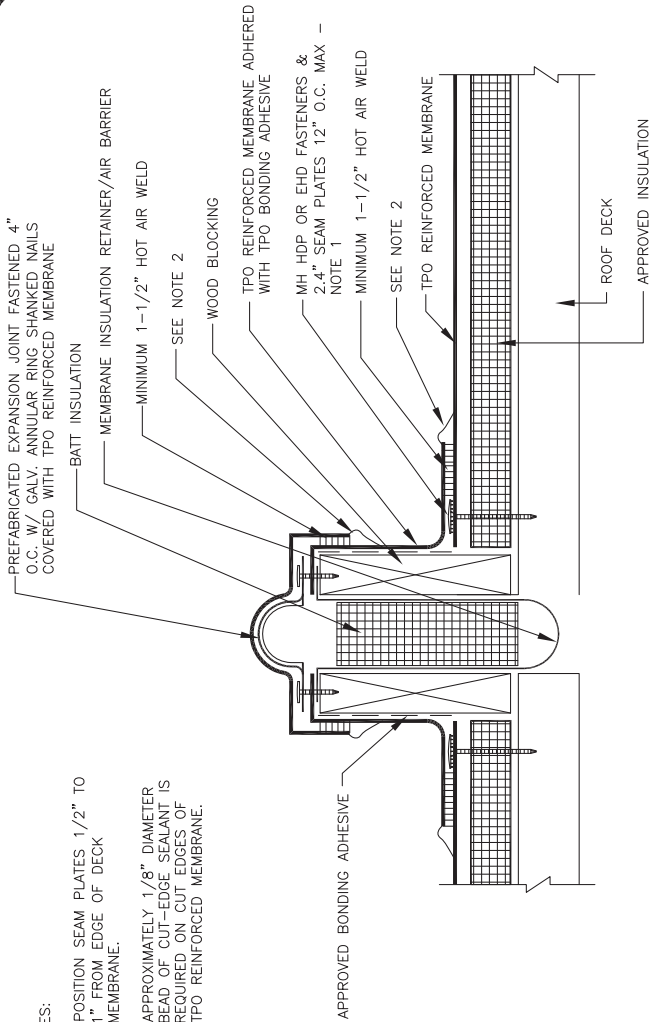

EXPANSION JOINT CURB  
SYSTEMS:  
ALL TPO SYSTEMS

DETAIL NO.:  
**MHT-UN-402**  
REVISION DATE: 10/2013

**MULE-HIDE  
PRODUCTS CO., INC.**

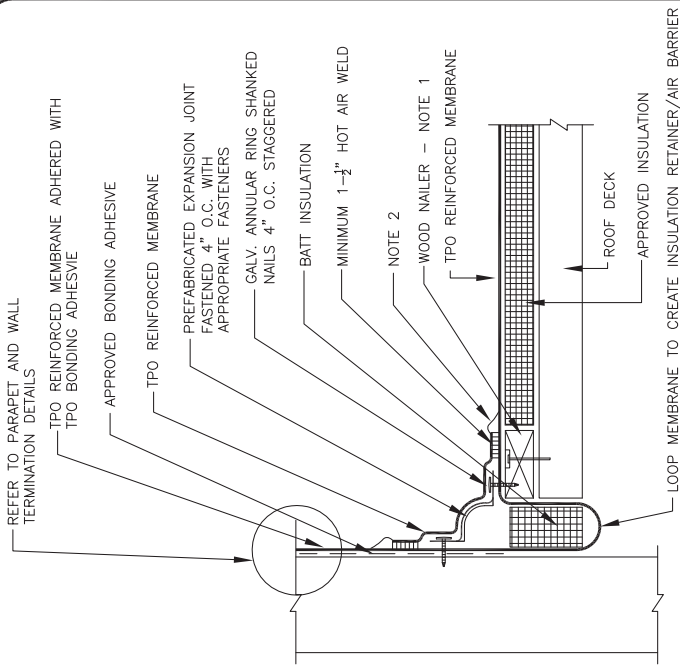

NOTES:

1. NAILERS SHALL BE SECURELY ANCHORED TO THE DECK AT A MAXIMUM SPACING OF 3 FEET TO RESIST A FORCE OF 175 LBS PER LINEAR FOOT IN ANY DIRECTION.
2. APPROXIMATELY 1/8" DIAMETER BEAD OF CUT-EDGE SEALANT IS REQUIRED ON CUT EDGES OF TPO REINFORCED MEMBRANE.

WALL EXPANSION JOINT

DETAIL NO.:

**MHT-UN-403**

SYSTEMS:

ALL TPO SYSTEMS

**MULE-HIDE PRODUCTS CO., INC.**

REVISION DATE: 10/2013



WIDTH OF JOINT SHALL BE A MINIMUM OF 3/4" AND SHALL NOT EXCEED 3".

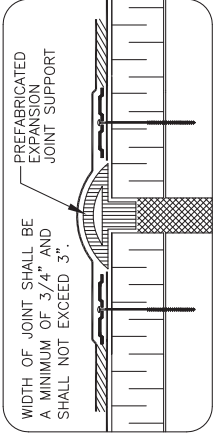

CLOSED CELL TUBING AND FILLER (BY OTHERS) OR PREFABRICATED EXPANSION JOINT SUPPORT (SEE INSET). TUBING DIAMETER TO BE 1.5 TIMES WIDTH OF OPENING

APPROVED INSULATION  
TPO REINFORCED MEMBRANE

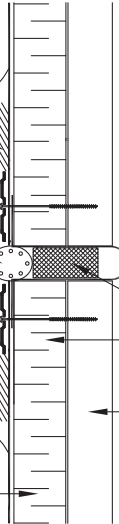

ROOF DECK  
APPROVED INSULATION  
BATT INSULATION  
MEMBRANE INSULATION RETAINER/AIR BARRIER

MINIMUM 1-3" HOT AIR WELD  
SEE NOTE 2

NOTES:

1. POSITION SEAM PLATES 1/2" MINIMUM TO 1" MAXIMUM FROM EDGE OF TPO DECK MEMBRANE.
2. APPROXIMATELY 1/8" DIAMETER BEAD OF CUT-EDGE SEALANT IS REQUIRED ON CUT EDGES OF TPO REINFORCED MEMBRANE.
3. MULE-HIDE RECOMMENDS THE USE OF CARLISLE PREFABRICATED EXPANSION JOINT SUPPORTS.

EXPANSION JOINT DETAILS

SYSTEMS:  
ALL TPO SYSTEMS

DETAIL NO.:

**MHT-UN-404A**

REVISION DATE: 10/2013

**MULE-HIDE  
PRODUCTS CO., INC.**

CREASE MEMBRANE AT ANGLE CHANGE TO  
LIMIT BRIDGING TO 3/4" MAXIMUM

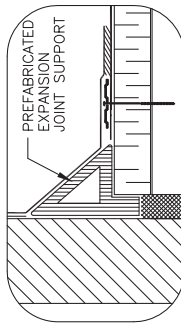

WIDTH OF JOINT SHALL BE A  
MINIMUM OF 3/4" AND SHALL NOT  
EXCEED 2".

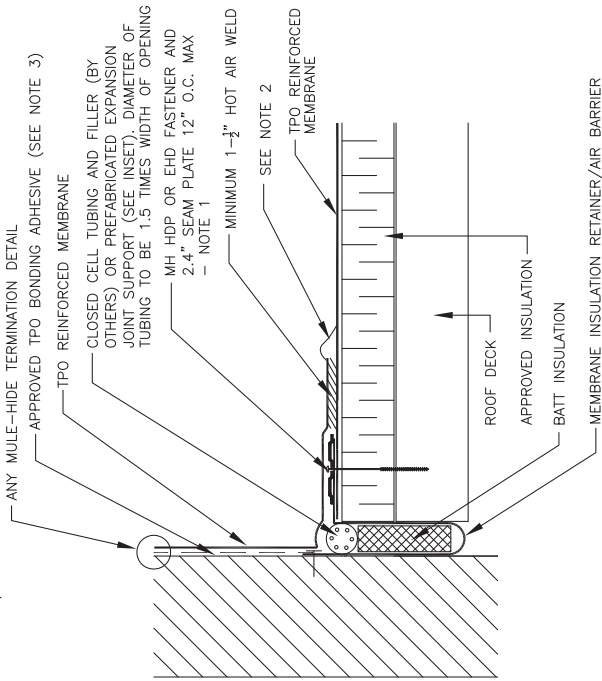

NOTES:

1. POSITION FASTENING PLATES 1/2" MINIMUM TO 1" MAXIMUM FROM EDGE OF DECK MEMBRANE.
2. APPROXIMATELY 1/8" DIAMETER BEAD OF EDGE SEALANT IS REQUIRED ON CUT EDGES OF TPO REINFORCED MEMBRANE.
3. TPO BONDING ADHESIVE IS REQUIRED REGARDLESS OF TERMINATION HEIGHT.
4. MULE-HIDE RECOMMENDS THE USE OF CARLISLE'S PREFABRICATED EXPANSION JOINT SUPPORT AS AN OPTION FOR THIS DETAIL.

WALL EXPANSION JOINT

SYSTEMS:  
ALL TPO SYSTEMS

DETAIL NO.:

**MHT-UN-404B**

REVISION DATE: 10/2013

**MULE-HIDE  
PRODUCTS CO., INC.**

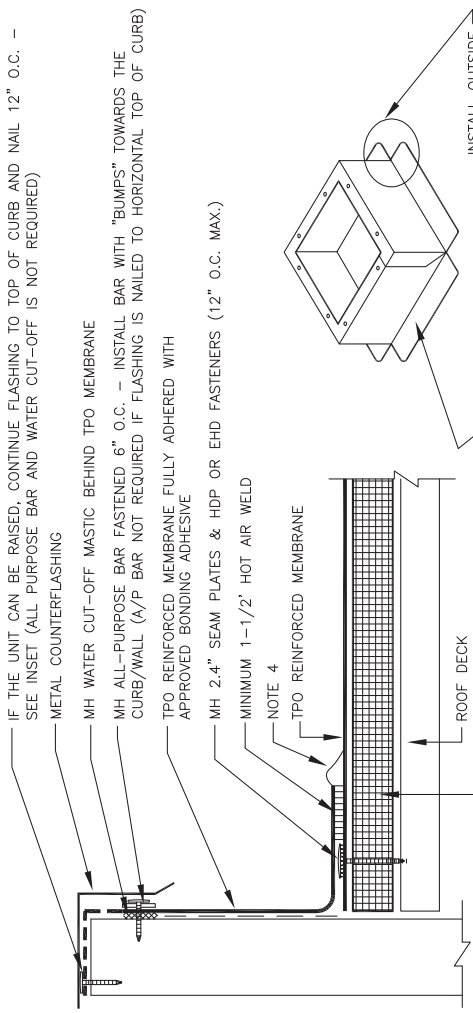

NOTES:

1. ALL FLASHING MUST BE A MINIMUM OF 8" HIGH WHERE POSSIBLE
2. DO NOT COVER WEEP HOLES OR THRU-WALL COUNTERFLASHINGS
3. WHEN THE M-H ALL-PURPOSE BAR IS USED UNDER THE COUNTERFLASHING OR THE MEMBRANE IS NAILED TO THE HORIZONTAL TOP OF THE CURB, TPO BONDING ADHESIVE MAY BE ELIMINATED WHEN FLASHING HEIGHT IS 18" OR LESS.
4. APPROXIMATELY 1/8" DIAMETER BEAD OF CUT-EDGE SEALANT IS REQUIRED ON CUT EDGES OF TPO REINFORCED MEMBRANE.

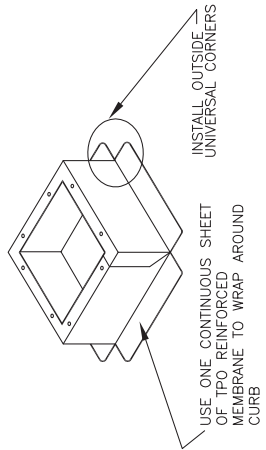

NOTE:  
THIS DETAIL IS ACCEPTABLE FOR USE IN A  
20-YEAR WARRANTED SYSTEM

<b>MULE-HIDE PRODUCTS CO., INC.</b>	<b>CURB / WALL FLASHING WITH M-H ALL-PURPOSE BAR SYSTEMS:</b>	<b>DETAIL NO.:</b> <b>MHT-UN-502</b>
	<b>ALL TPO SYSTEMS</b>	REVISION DATE: 10/2013

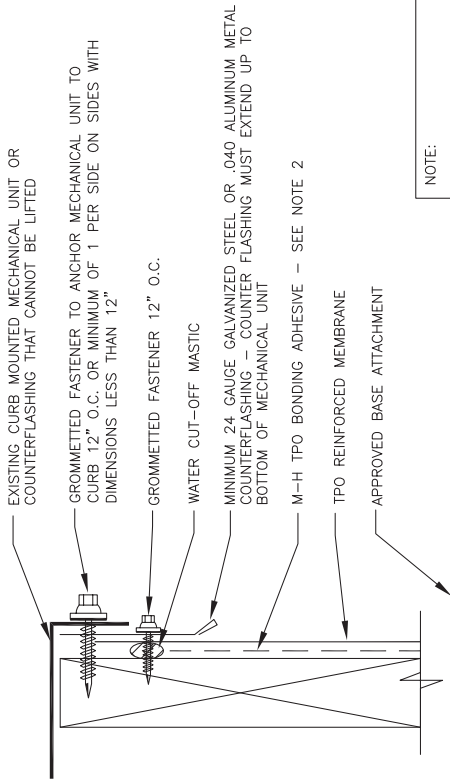

NOTE:  
 THIS DETAIL IS ACCEPTABLE FOR USE IN A  
 20-YEAR WARRANTED SYSTEM

NOTES:

1. ALL FLASHING MUST BE A MINIMUM OF 8" HIGH WHERE POSSIBLE
2. WHEN COUNTERFLASHING IS USED FOR TERMINATION, BONDING ADHESIVE IS NOT REQUIRED WHEN FLASHING HEIGHT IS 12" OR LESS.

<b>MULE-HIDE          PRODUCTS CO., INC.</b>	<b>CURB / WALL FLASHING          WITH COUNTERFLASHING          SYSTEMS:</b>	<b>DETAIL NO.:</b> <b>MHT-UN-502A</b>
	<b>ALL TPO SYSTEMS</b>	REVISION DATE: 02/2017

CREASE MEMBRANE AT ANGLE CHANGE TO  
LIMIT BRIDGING TO 3/4" MAXIMUM

INSTALL OUTSIDE  
UNIVERSAL CORNERS

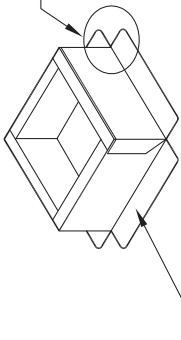

USE ONE CONTINUOUS SHEET  
OF TPO REINFORCED  
MEMBRANE TO WRAP AROUND  
CURB

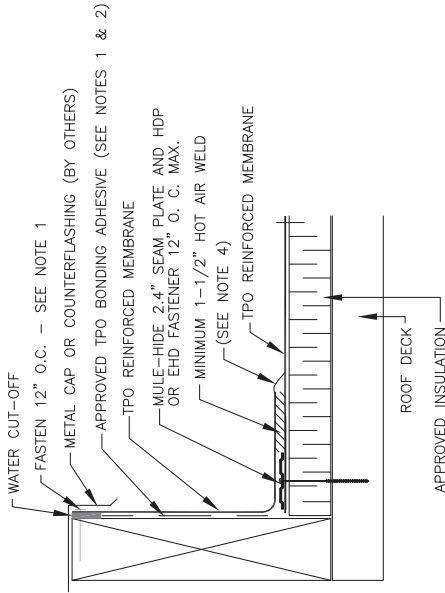

NOTE:

THIS DETAIL IS NOT ACCEPTABLE FOR USE  
IN A 20-YEAR WARRANTED SYSTEM.

NOTES:

1. TPO REINFORCED MEMBRANE FASTENED APPROXIMATELY 12" ON CENTER. IF FASTENER PENETRATES METAL COUNTERFLASHING, USE NEOPRENE WASHER OR APPLY WATER CUT-OFF MASTIC UNDER COUNTERFLASHING OR CAULK FASTENER HEAD.
2. APPROXIMATELY 1/8" BEAD OF CUT-EDGE SEALANT IS REQUIRED ON CUT EDGES OF TPO REINFORCED MEMBRANE.

CURB FLASHING

SYSTEMS:  
ALL TPO SYSTEMS

DETAIL NO.:

**MHT-UN-503**

REVISION DATE: 10/2013

**MULE-HIDE  
PRODUCTS CO., INC.**

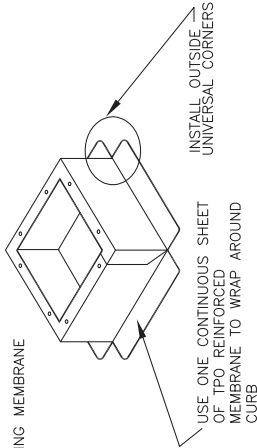
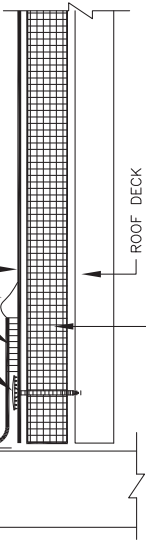
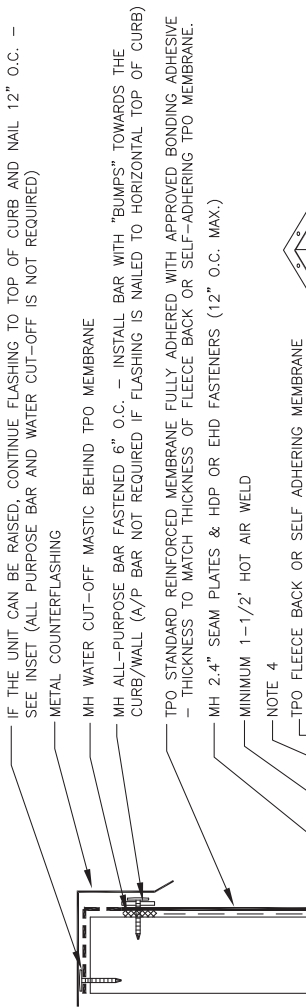

**NOTES:**

1. ALL FLASHING MUST BE A MINIMUM OF 8" HIGH WHERE POSSIBLE
2. DO NOT COVER WEEP HOLES OR THRU-WALL COUNTERFLASHINGS
3. WHEN THE M-H ALL-PURPOSE BAR IS USED UNDER THE COUNTERFLASHING OR THE MEMBRANE IS NAILED TO THE HORIZONTAL TOP OF THE CURB, TPO BONDING ADHESIVE MAY BE ELIMINATED WHEN FLASHING HEIGHT IS 18" OR LESS.
4. APPROXIMATELY 1/8" DIAMETER BEAD OF CUT-EDGE SEALANT IS REQUIRED ON CUT EDGES OF TPO REINFORCED MEMBRANE.

**NOTE:**  
THIS DETAIL IS ACCEPTABLE FOR USE IN A 20-YEAR WARRANTED SYSTEM

**CURB / WALL FLASHING WITH M-H ALL-PURPOSE BAR SYSTEMS:**

**DETAIL NO.:**

**MHT-UN-503A**

REVISION DATE: 10/2013

**MULE-HIDE PRODUCTS CO., INC.**

**ALL TPO FLEECE BACK & SELF ADHERING**

FOR DRAINS WITH TAPERED INSULATION AT DRAIN SUMP  
LESS THAN 3 INCHES TO 12"

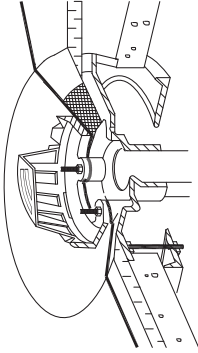
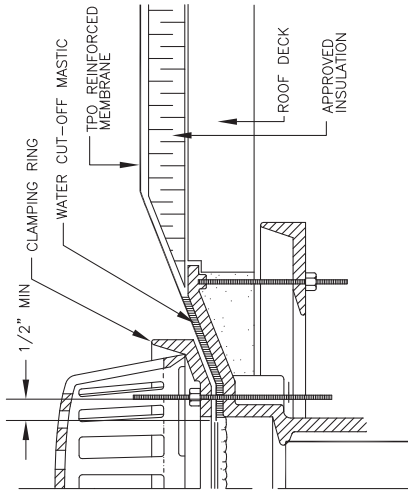

NOTES:

1. REMOVE ALL LEAD AND OTHER FLASHING.
2. ALL BOLTS AND CLAMPS MUST BE IN PLACE TO PROVIDE CONSTANT COMPRESSION ON WATER CUT-OFF MASTIC.
3. CUT THE MEMBRANE SO IT EXTENDS A MINIMUM OF 1/2" FROM THE ATTACHMENT POINTS OF THE DRAIN CLAMPING RING.
4. FOR DRAIN SUMPS WITH SLOPES GREATER THAN 3" IN 12" REFER TO DETAIL MHT-UN-511A.
5. DO NOT LOCATE FIELD SEAM WITHIN THE DRAIN OR DRAIN SUMP. IF FIELD SEAM OCCURS IN DRAIN OR DRAIN SUMP, A TARGET PATCH MUST BE INSTALLED. SEE APPROPRIATE TARGET PATCH DETAIL.

**DRAIN FLASHING - TAPERED INSULATION**  
**DRAIN SUMP SLOPE LESS THAN 3" TO 1"**  
**SYSTEMS:**

**ALL TPO SYSTEMS**

**DETAIL NO.:**

**MHT-UN-510A**

REVISION DATE: 10/2013

**MULE-HIDE  
PRODUCTS CO., INC.**

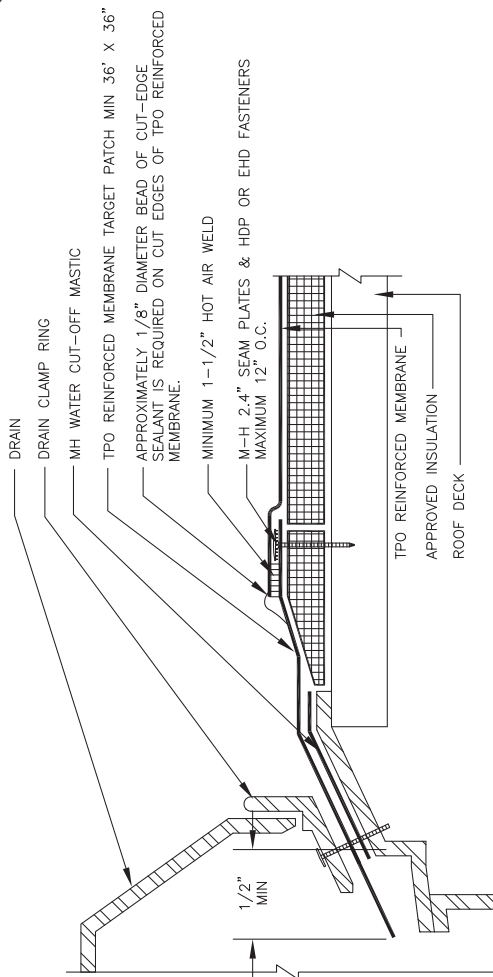

NOTES:

1. REMOVE ALL LEAD AND OTHER FLASHING.
2. ALL BOLTS AND CLAMPS MUST BE IN PLACE TO PROVIDE CONSTANT COMPRESSION ON WATER CUT-OFF MASTIC.
3. CUT THE MEMBRANE SO IT EXTENDS A MINIMUM OF 1/2" FROM THE ATTACHMENT POINTS OF THE DRAIN CLAMPING RING.
4. FOR DRAIN SUMPS WITH SLOPES GREATER THAN 3" IN 12" REFER TO DETAIL MHT-UN-511A.
5. THIS TWO PIECE DESIGN MUST BE USED WHEN A FIELD SEAM PASSES THROUGH THE DRAIN AREA.

**MULE-HIDE  
PRODUCTS CO., INC.**

**DRAIN FLASHING  
WITH TARGET PATCH  
SYSTEMS:**

**MECHANICALLY ATTACHED**

**DETAIL NO.:**

**MHT-MA-510B**

REVISION DATE: 10/2013



ENTIRE SEAM OVERLAP AT DRAIN  
BASE MUST BE HOT AIR WELDED  
TPO REINFORCED MEMBRANE

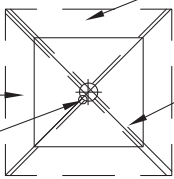

4. TRIANGULAR SECTIONS OF  
TPO REINFORCED MEMBRANE  
MIN. 1-1/2" HOT AIR WELD

NOTES:

1. REMOVE ALL LEAD AND OTHER FLASHING.
2. EXTEND THE TPO REINFORCED MEMBRANE APPROXIMATELY 5-1/2" OUT OF THE SUMP AREA.
3. ALL BOLTS OR CLAMPS MUST BE IN PLACE TO PROVIDE COMPRESSION ON WATER CUT-OFF MASTIC.
4. CUT THE MEMBRANE SO IT EXTENDS A MINIMUM OF 1/2" FROM THE ATTACHMENT POINTS OF THE DRAIN CLAMPING RING.
5. APPROXIMATELY 1/8" DIAMETER BEAD OF CUT-EDGE SEALANT IS REQUIRED ON CUT EDGE OF TPO REINFORCED MEMBRANE.
6. MECHANICALLY ATTACHED SYSTEMS WILL REQUIRE HDP OR EHD FASTENERS AND 2.4" SEAM PLATES (12" O.C. MAX.) INSTALLED IN TARGET PANELS WITH FIELD SHEET OVERLAPPED AND HOT AIR WELDED (REFER TO DETAIL MHT-MA-510B).

FOR DRAINS WITH TAPERED INSULATION AT DRAIN SUMP  
GREATER THAN 3" TO 12"

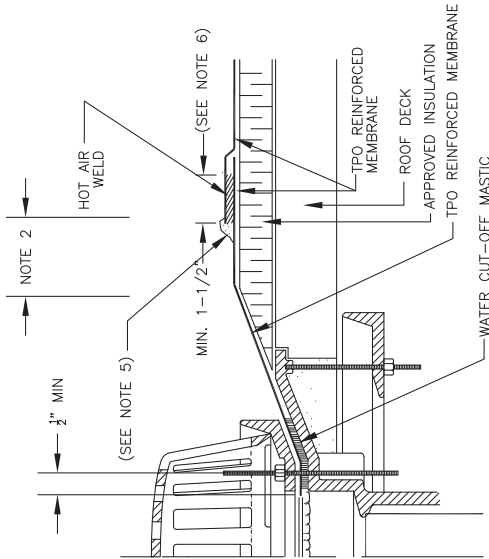

**DRAIN FLASHING WITH TARGET PANELS  
DRAIN SUMP SLOPE GREATER THAN 3" TO 12"  
SYSTEMS:**

**ALL TPO SYSTEMS**

**DETAIL NO.:**  
**MHT-UN-511A**

REVISION DATE: 10/2013

**MULE-HIDE  
PRODUCTS CO., INC.**

FOR DRAINS WITH TAPERED INSULATION AT DRAIN SUMP  
GREATER THAN 3" TO 1 HORIZONTAL FOOT

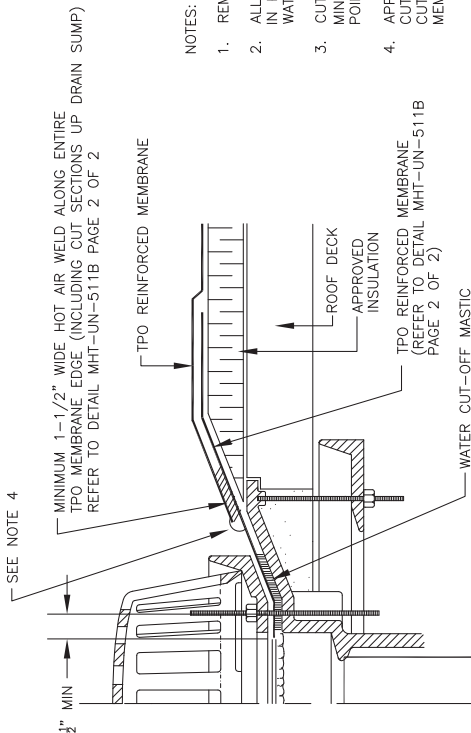

NOTES:

1. REMOVE ALL LEAD AND OTHER FLASHING.
2. ALL DRAIN BOLTS OR CLAMPS MUST BE IN PLACE TO PROVIDE COMPRESSION ON WATER CUT-OFF MASTIC.
3. CUT MEMBRANE SO IT EXTENDS A MINIMUM OF 1/2" FROM ATTACHMENT POINTS OF THE CLAMPING RING.
4. APPROXIMATELY 1/8" DIAMETER BEAD OF CUT-EDGE SEALANT IS REQUIRED ON CUT EDGES OF TPO REINFORCED MEMBRANE.

DRAIN FLASHING WITH TARGET  
PAGE 1 OF 2  
SYSTEMS:

ALL TPO SYSTEMS

DETAIL NO.:

**MHT-UN-511B1**

REVISION DATE: 10/2013

**MULE-HIDE  
PRODUCTS CO., INC.**

FOR DRAINS WITH TAPERED INSULATION AT DRAIN SUMP  
GREATER THAN 3" TO 1 HORIZONTAL FOOT

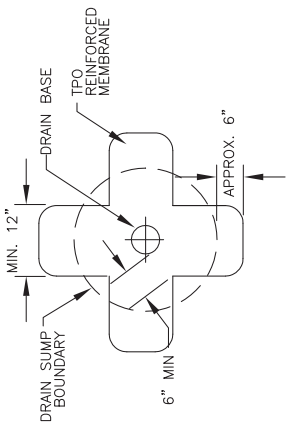

CUT SECTION OF TPO REINFORCED MEMBRANE AS  
SHOWN AND POSITION INTO DRAIN SUMP. EXTEND  
MEMBRANE OUT OF DRAIN SUMP APPROXIMATELY  
6" (ROUND CORNERS).

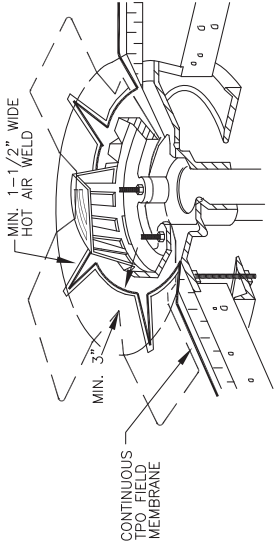
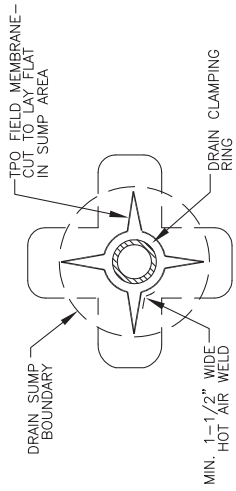

EXTEND TPO REINFORCED MEMBRANE ONTO  
MEMBRANE SECTION POSITIONED AT DRAIN SUMP AND  
CUT AS SHOWN TO LAY FLAT IN SUMP. HOT AIR  
WELD A MINIMUM OF 1-1/2" COMPLETELY  
SURROUNDING AREA.

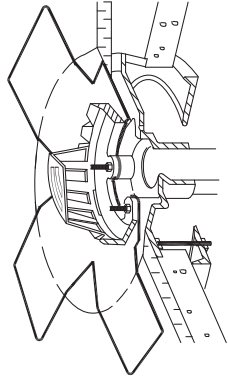

**DRAIN FLASHING WITH TARGET**  
PAGE 2 OF 2  
SYSTEMS:

ALL TPO SYSTEMS

**DETAIL NO.:**

**MHT-UN-511B2**

REVISION DATE: 10/2013

**MULE-HIDE  
PRODUCTS CO., INC.**

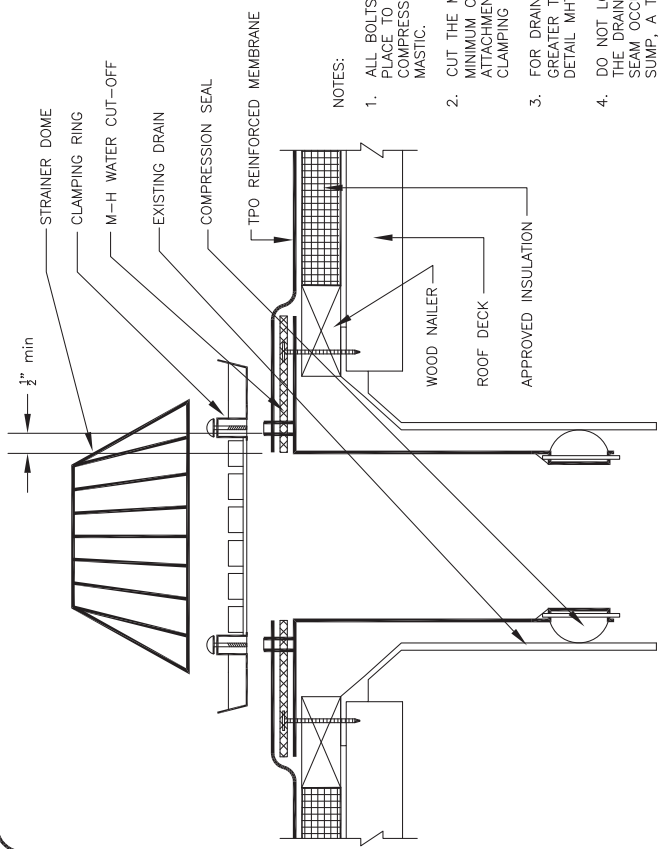

NOTES:

1. ALL BOLTS AND CLAMPS MUST BE IN PLACE TO PROVIDE CONSTANT COMPRESSION ON WATER CUT-OFF MASTIC.
2. CUT THE MEMBRANE SO IT EXTENDS A MINIMUM OF 1/2" FROM THE ATTACHMENT POINTS OF THE DRAIN CLAMPING RING.
3. FOR DRAIN SUMPS WITH SLOPES GREATER THAN 3" IN 12' REFER TO DETAIL MHT-UN-511A.
4. DO NOT LOCATE FIELD SEAM WITHIN THE DRAIN OR DRAIN SUMP. IF FIELD SEAM OCCURS IN DRAIN OR DRAIN SUMP, A TARGET PATCH MUST BE INSTALLED. SEE APPROPRIATE TARGET PATCH DETAIL.

<b>MULE-HIDE PRODUCTS CO., INC.</b>	<b>RETROFIT ROOF DRAIN COMPRESSION TYPE INSERT SYSTEMS: ALL TPO SYSTEMS</b>
<b>DETAIL NO.: MHT-UN-512</b> REVISION DATE: 10/2013	

NOTES:

1. CUT THE MEMBRANE SO IT EXTENDS A MINIMUM OF 1/2" FROM THE ATTACHMENT POINTS OF THE DRAIN CLAMPING RING.
2. THE CLAMPING RING BOLT MUST PENETRATE THE MEMBRANE.
3. ALL FLASHINGS ON A TPO FLEECEBACK PROJECT MUST BE CONSTRUCTED WITH STANDARD REINFORCED TPO MEMBRANE.
4. APPROXIMATELY 1/8" BEAD OF CUT-EDGE SEALANT IS REQUIRED ON CUT EDGES OF TPO REINFORCED MEMBRANE.
5. THICKNESS OF STANDARD TPO MEMBRANE TO MATCH THICKNESS OF FLEECEBACK TPO MEMBRANE.

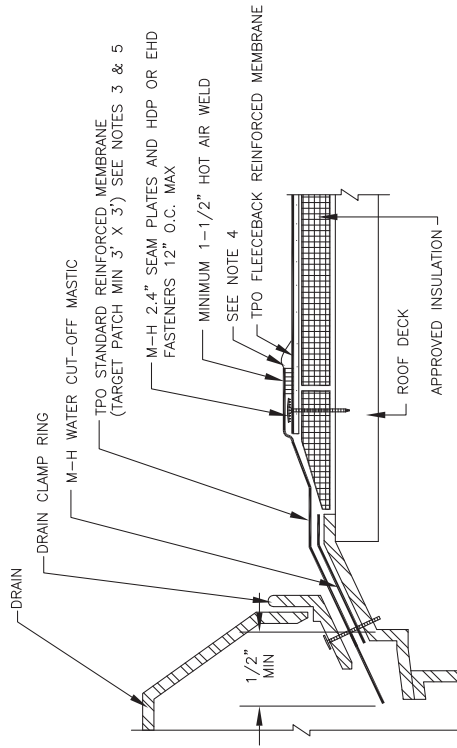

<b>MULE-HIDE PRODUCTS CO., INC.</b>	<b>DRAIN FLASHING WITH TARGET SYSTEMS: MECHANICALLY ATTACHED TPO FLEECE BACK</b>	<b>DETAIL NO.:</b> <b>MHT-MA-510C</b> REVISION DATE: 10/2013

NOTES:

1. CUT THE MEMBRANE SO IT EXTENDS A MINIMUM OF 1/2" FROM THE ATTACHMENT POINTS OF THE DRAIN CLAMPING RING.
2. THE CLAMPING RING BOLT MUST PENETRATE THE MEMBRANE.
3. ALL FLASHINGS ON A TPO FLEECEBACK OR SELF ADHERING PROJECT MUST BE CONSTRUCTED WITH STANDARD REINFORCED TPO MEMBRANE.
4. APPROXIMATELY 1/8" BEAD OF CUT-EDGE SEALANT IS REQUIRED ON CUT EDGES OF TPO REINFORCED MEMBRANE.
5. THICKNESS OF STANDARD TPO MEMBRANE TO MATCH THICKNESS OF FLEECEBACK TPO OR SELF ADHERING MEMBRANE.

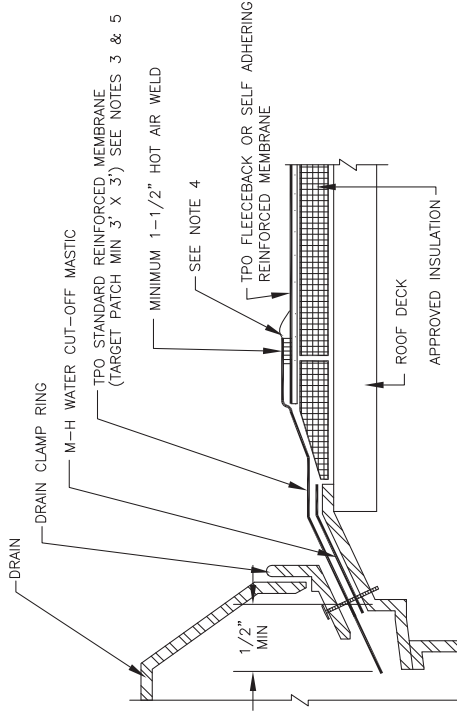

DRAIN FLASHING  
WITH TARGET

SYSTEMS:  
FULLY ADHERED  
TPO FLEECE BACK & SELF ADHERING

DETAIL NO.:

**MHT-FA-510D**

REVISION DATE: 10/2013

**MULE-HIDE  
PRODUCTS CO., INC.**

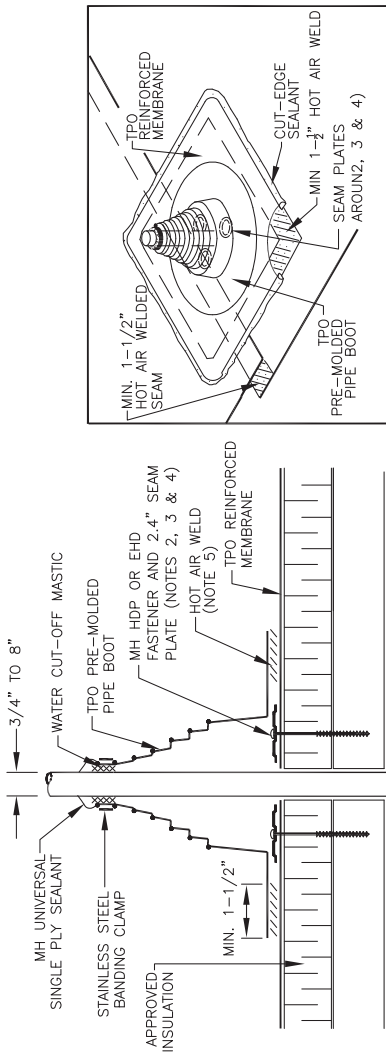

TARGET PATCH REQUIRED WHEN FIELD SEAM INTERSECTS PIPE BOOT FLANGE

NOTES:

1. REMOVE ALL LEAD AND OTHER FLASHING BEFORE INSTALLING FIELD FABRICATED PIPE SEAL.
2. ON MECHANICALLY ATTACHED SYSTEMS, INSTALL 3 FASTENERS AND PLATES AROUND PIPE EQUALLY SPACED. FASTENERS MAY ALSO BE POSITIONED MAXIMUM 12" FROM PIPE, FASTENED 12" O.C. AND FLASHED WITH TPO REINFORCED MEMBRANE.
3. FASTENERS AND SEAM PLATES ARE NOT REQUIRED ON ADHERED SYSTEMS UNLESS PROJECTION DIAMETER EXCEEDS 18".
4. IF SEAM PLATES CANNOT BE INSTALLED AS SHOWN THEY CAN BE POSITIONED OUTSIDE THE PIPE FLASHING FLANGE AS SHOWN ON DETAIL MHT-UN-521A
5. PIPE BOOT DECK FLANGE MUST BE HOT AIR WELDED A MINIMUM OF 1-1/2" BEYOND SEAM PLATES.
6. TEMPERATURE OF PIPE NOT TO EXCEED 160° F
7. INSTALL A SECTION OF TPO REINFORCED MEMBRANE OVER SEAM INTERSECTIONS PRIOR TO INSTALLING PRE-MOLDED PIPE BOOT - SEE INSET.
8. DO NOT CUT PIPE BOOTS TO PULL AROUND PROJECTION. PRE-MOLDED PIPE BOOTS MUST BE SLIPPED OVER THE PIPE.
9. PRE-MOLDED PIPE BOOTS ARE NOT TO BE USED AS PITCH PANS.

PRE-MOLDED PIPE BOOT

DETAIL NO.:

**MHT-UN-520**

REVISION DATE: 10/2013

SYSTEMS:

ALL TPO SYSTEMS

**MULE-HIDE  
PRODUCTS CO., INC.**

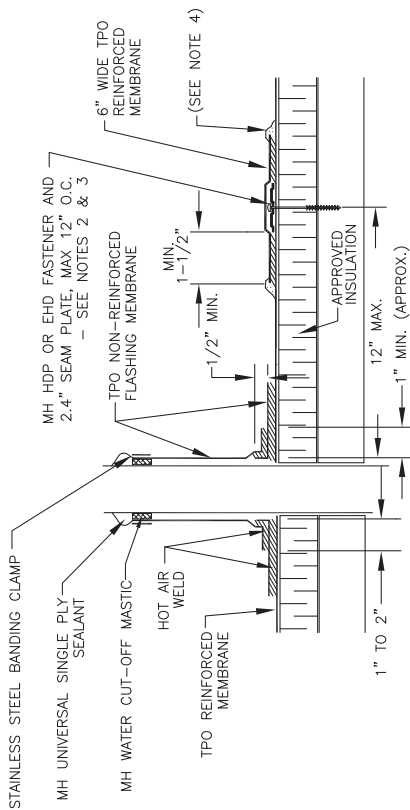

APPLY HEAT TO FLASHING AND FORM BY HAND PRIOR TO HOT AIR WELDING

NOTES:

1. REMOVE ALL LEAD AND OTHER FLASHING BEFORE INSTALLING FIELD FABRICATED PIPE SEAL.
2. ON MECHANICALLY ATTACHED SYSTEMS, INSTALL A MINIMUM OF FOUR (4) 2.4" SEAM PLATES AROUND PROJECTIONS WITH A DIMENSION UP TO 6". ADDITIONAL SEAM PLATES WILL BE REQUIRED FOR PROJECTIONS WITH DIAMETERS GREATER THAN 6" AND SHALL BE SPACED 12" ON CENTER MAX.
3. FASTENERS AND SEAM PLATES ARE NOT REQUIRED ON ADHERED SYSTEMS UNLESS PROJECTION DIAMETER EXCEEDS 18".
4. APPROXIMATELY 1/8" DIAMETER BEAD OF CUT-EDGE SEALANT IS REQUIRED ON CUT EDGES OF TPO REINFORCED MEMBRANE.
5. TEMPERATURE OF PIPE NOT TO EXCEED 160° F.

<b>MULE-HIDE PRODUCTS CO., INC.</b>	<b>FIELD FABRICATED PIPE FLASHING WITH BANDING CLAMP SYSTEMS:</b>	<b>DETAIL NO.:</b> <b>MHT-UN-521A</b>
	<b>ALL TPO SYSTEMS</b>	REVISION DATE: 10/2013



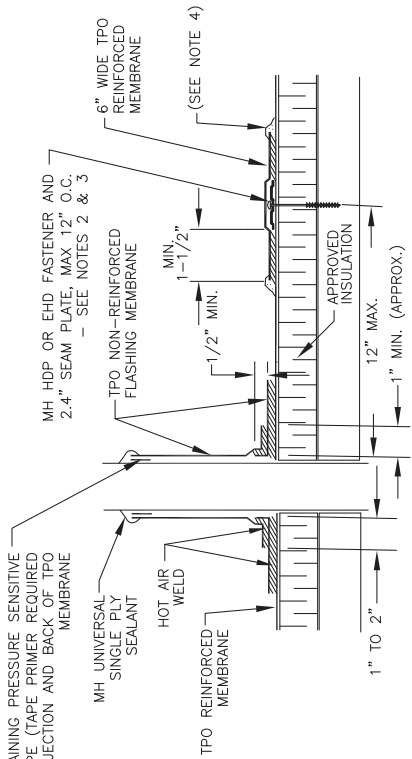

APPLY HEAT TO FLASHING AND FORM BY HAND PRIOR TO HOT AIR WELDING

NOTES:

1. REMOVE ALL LEAD AND OTHER FLASHING BEFORE INSTALLING FIELD FABRICATED PIPE SEAL.
2. ON A MECHANICALLY ATTACHED SYSTEM, INSTALL A MINIMUM OF FOUR (4) 2.4" SEAM PLATES AROUND PROJECTIONS WITH A DIMENSION UP TO 6". ADDITIONAL SEAM PLATES WILL BE REQUIRED FOR PROJECTIONS WITH DIAMETERS GREATER THAN 6" AND SHALL BE SPACED 12" ON CENTER MAX.
3. FASTENERS AND SEAM PLATES ARE NOT REQUIRED ON ADHERED SYSTEMS UNLESS PROJECTION DIAMETER EXCEEDS 18".
4. APPROXIMATELY 1/8" DIAMETER BEAD OF CUT-EDGE SEALANT IS REQUIRED ON CUT EDGES OF TPO REINFORCED MEMBRANE.
5. TEMPERATURE OF PIPE NOT TO EXCEED 160° F.

FIELD FABRICATED PIPE FLASHING WITH SEAM TAPE SYSTEMS:

ALL TPO SYSTEMS

DETAIL NO.:

**MHT-UN-521B**

REVISION DATE: 10/2013

**MULE-HIDE PRODUCTS CO., INC.**

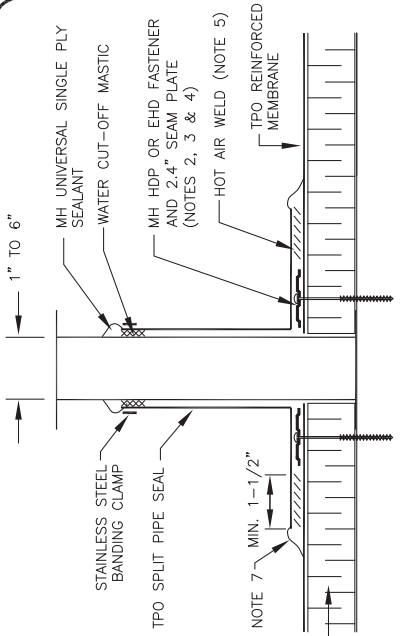
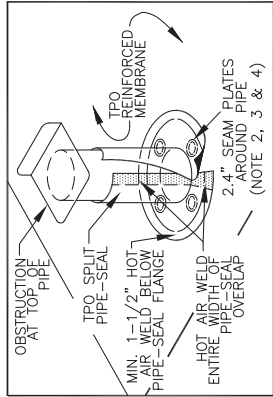

APPROVED INSULATION

NOTES:

1. REMOVE ALL LEAD AND OTHER FLASHING BEFORE INSTALLING SPLIT PIPE SEAL.
2. ON MECHANICALLY ATTACHED SYSTEMS, INSTALL A MINIMUM OF FOUR (4) 2.4" SEAM PLATES AROUND PROJECTIONS WITH A DIMENSION UP TO 6". ADDITIONAL SEAM PLATES WILL BE REQUIRED FOR PROJECTIONS WITH DIAMETERS GREATER THAN 6" AND SHALL BE SPACED 12" ON CENTER MAX.
3. FASTENERS AND SEAM PLATES ARE NOT REQUIRED ON ADHERED SYSTEMS UNLESS PROJECTION DIAMETER EXCEEDS 18".
4. IF SEAM PLATES CANNOT BE INSTALLED AS SHOWN THEY CAN BE POSITIONED OUTSIDE THE PIPE FLASHING FLANGE AS SHOWN ON DETAIL MHT-UN-521A.
5. PIPE FLASHING DECK FLANGE MUST BE HOT AIR WELDED A MINIMUM OF 1-1/2" BEYOND SEAM PLATES.
6. TEMPERATURE OF PIPE NOT TO EXCEED 160° F.
7. APPROXIMATELY 1/8" DIAMETER BEAD OF CUT-EDGE SEALANT IS REQUIRED ON CUT EDGE OF TPO REINFORCED MEMBRANE.
8. TPO SPLIT PIPE BOOTS ARE NOT TO BE USED AS PITCH PANS.

TPO SPLIT PIPE BOOT

DETAIL NO.:

SYSTEMS:  
ALL TPO SYSTEMS

**MHT-UN-521C**  
REVISION DATE: 10/2013

**MULE-HIDE PRODUCTS CO., INC.**

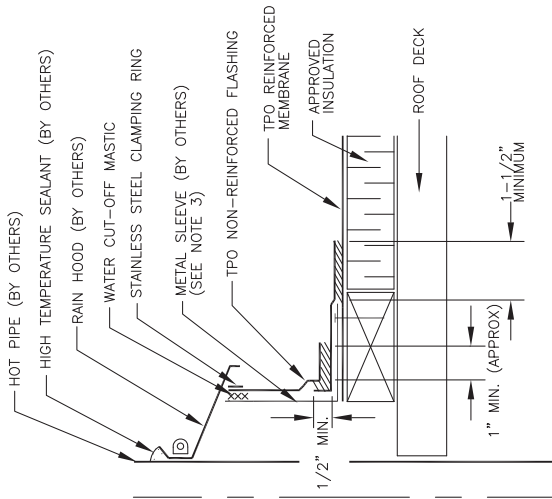

PRE-HEAT AND PRE-STRETCH TPO  
NON-REINFORCED FLASHING  
MEMBRANE TO FORM AROUND PIPE  
PRIOR TO HOT AIR WELDING IN PLACE

NOTES:

1. THIS DETAIL USED FOR FIELD-FABRICATED PIPE SEAL FOR USE WITH HOT PIPE, 160° F OR HOTTER.
2. TPO NON-REINFORCED FLASHING WRAPPED AROUND PIPE SHALL HAVE MINIMUM 1-1/2" VERTICAL HOT AIR WELD.
3. TEMPERATURE OF METAL SLEEVE MUST NOT EXCEED 160° F.

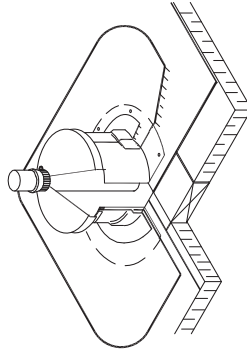

HOT PIPE FLASHING  
WITH COLD SLEEVE  
SYSTEMS:

ALL TPO SYSTEMS

**MULE-HIDE  
PRODUCTS CO., INC.**

DETAIL NO.:  
**MHT-UN-522**

REVISION DATE: 10/2013

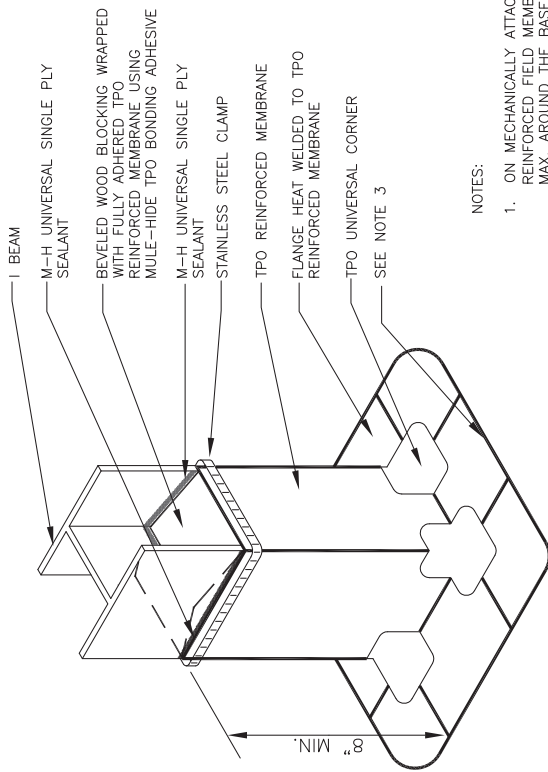

NOTES:

1. ON MECHANICALLY ATTACHED SYSTEMS, FASTEN TPO REINFORCED FIELD MEMBRANE (NOT SHOWN) 12" O.C. MAX. AROUND THE BASE OF THE BEAM.
2. WOOD BLOCKING MUST BE EMBEDDED IN A LAYER OF M-H UNIVERSAL SINGLE PLY SEALANT PRIOR TO FLASHING.
3. APPROXIMATELY 1/8" DIAMETER BEAD OF CUT-EDGE SEALANT IS REQUIRED ON CUT EDGES OF TPO REINFORCED MEMBRANE.

I-BEAM SUPPORT FLASHING

DETAIL NO.:

**MHT-UN-523**

REVISION DATE: 10/2013

SYSTEMS:

ALL TPO SYSTEMS

**MULE-HIDE  
PRODUCTS CO., INC.**

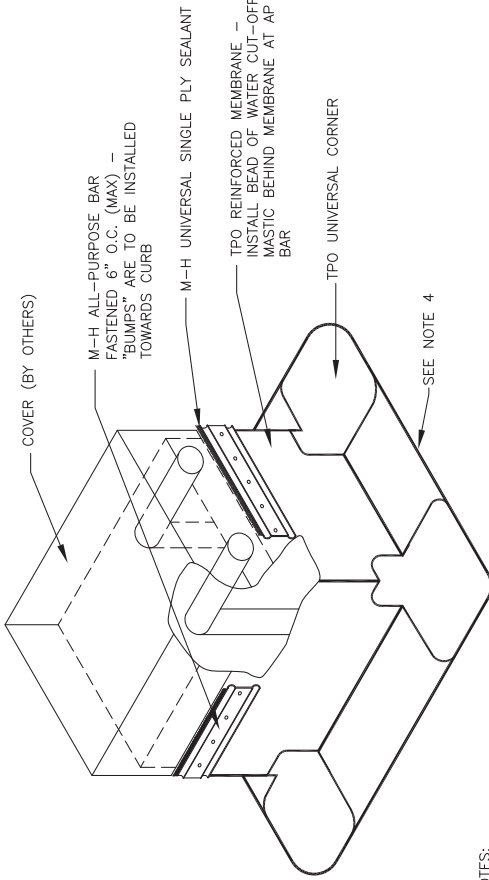

NOTES:

1. SLOPE TOP OF COVER AWAY FROM EXISTING PIPES.
2. IT IS THE CONTRACTOR'S RESPONSIBILITY TO SEAL AROUND THE PIPES AT THE COVER OPENINGS.
3. ON A MECHANICALLY ATTACHED SYSTEM, INSTALL A MINIMUM OF FOUR (4) 2.4" SEAM PLATES AROUND PROJECTIONS WITH A DIMENSION UP TO 6". ADDITIONAL SEAM PLATES WILL BE REQUIRED FOR PROJECTIONS WITH DIMENSIONS GREATER THAN 6" AND SHALL BE SPACED 12" ON CENTER MAX.
4. APPROXIMATELY 1/8" DIAMETER BEAD OF CUT-EDGE SEALANT IS REQUIRED ON CUT EDGES OF TPO REINFORCED MEMBRANE.

<b>MULE-HIDE PRODUCTS CO., INC.</b>	<b>MULTIPLE PIPE PENETRATION</b>	<b>DETAIL NO.:</b> <b>MHT-UN-525</b>
	<b>SYSTEMS:</b> <b>ALL TPO SYSTEMS</b>	REVISION DATE: 10/2013

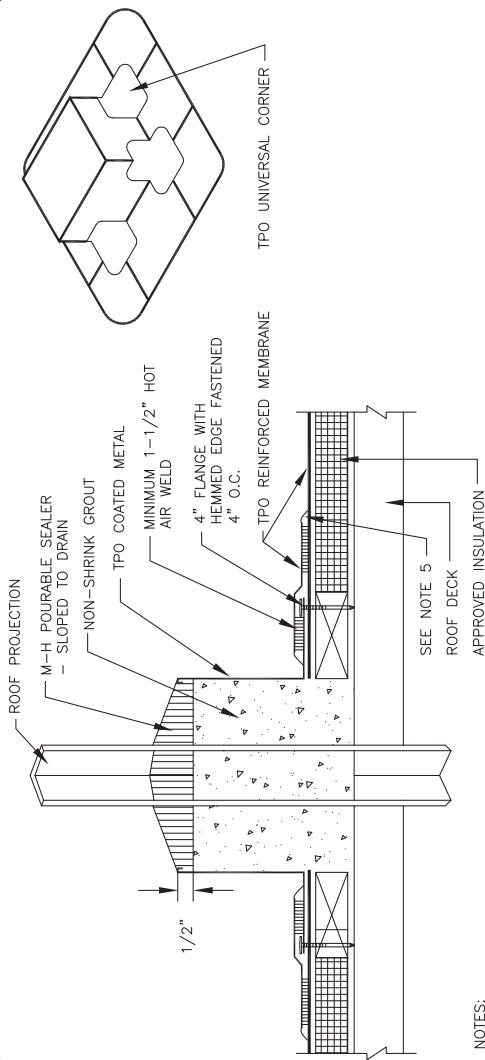

NOTES:

1. BEND TPO COATED METAL TO FORM A PITCH PAN AS SHOWN.
2. ALLOW 2" CLEARANCE AROUND THE PROJECTION
3. ALLOW GROUT TO CURE AND DRY BEFORE APPLYING POURABLE SEALER.
4. INSIDE SURFACE OF TPO COATED METAL PITCH PAN (BARE METAL SIDE) AND OUTSIDE FACES OF PROJECTION MUST BE CLEAN AND PRIMED WITH MULE-HIDE TAPE PRIMER.
5. APPROXIMATELY 1/8" DIAMETER BEAD OF CUT-EDGE SEALANT IS REQUIRED ON CUT EDGES OF TPO REINFORCED MEMBRANE.
6. PRE-MOLDED PIPE BOOTS ARE NOT TO BE USED AS PITCH PANS.

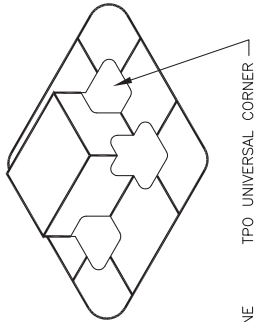

**MULE-HIDE  
PRODUCTS CO., INC.**

**PITCH PAN  
MEMBRANE COATED METAL  
SYSTEMS:  
ALL TPO SYSTEMS**

**DETAIL NO.:**  
**MHT-UN-526**  
REVISION DATE: 10/2013

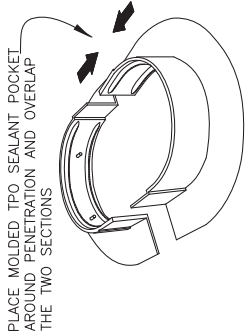
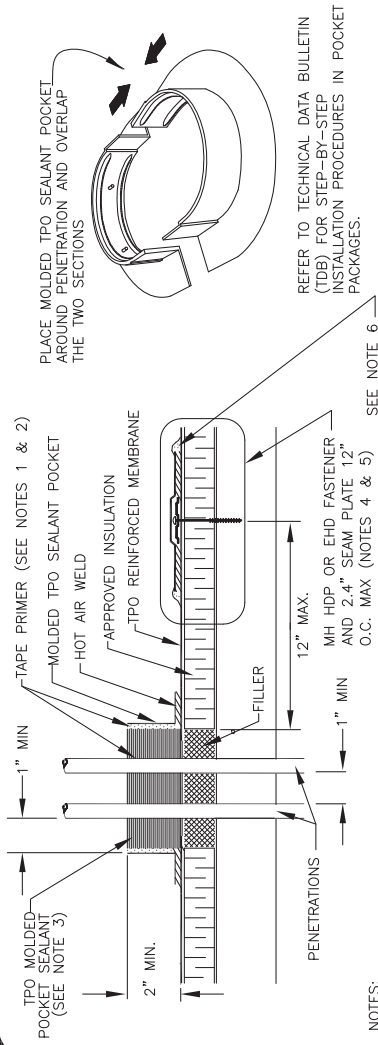

REFER TO TECHNICAL DATA BULLETIN (TDB) FOR STEP-BY-STEP INSTALLATION PROCEDURES IN POCKET PACKAGES.

SEE NOTE 6

NOTES:

1. TAPE PRIMER MUST BE APPLIED TO ALL INSIDE SURFACES AND PENETRATIONS PRIOR TO FILLING WITH SEALANT.
2. FILL POCKET COMPLETELY WITH THERMOPLASTIC POURABLE SEALER UNTIL THE RIM IS COVERED WITH SEALANT, ENSURE ALL VOIDS ARE FILLED.
3. SEALANT POCKET TO BE MINIMUM 1" FROM PENETRATION ON ANY SIDE.
4. ON MECHANICALLY FASTENED SYSTEMS, INSTALL A MINIMUM OF FOUR (4) 2.4" SEAM PLATES AROUND PROJECTIONS WITH A DIMENSION UP TO 6". ADDITIONAL SEAM PLATES WILL BE REQUIRED FOR PROJECTIONS WITH DIAMETERS GREATER THAN 6" AND SHALL BE SPACED 12" ON CENTER MAX.
5. FASTENERS AND SEAM PLATES ARE NOT REQUIRED ON ADHERED SYSTEMS UNLESS PROJECTION DIAMETER EXCEEDS 18".
6. APPROXIMATELY 1/8" DIAMETER BEAD OF CUT-EDGE SEALANT IS REQUIRED ON CUT EDGES OF TPO REINFORCED MEMBRANE.
7. TEMPERATURE OF PENETRATION NOT TO EXCEED 160° F.
8. PRE-MOLDED PIPE BOOTS ARE NOT TO BE USED AS PITCH PANS.

<b>MULE-HIDE PRODUCTS CO., INC.</b>	<b>TPO MOLDED SEALANT POCKET</b>	<b>DETAIL NO.:</b> <b>MHT-UN-527</b>
	<b>SYSTEMS:</b> <b>ALL TPO SYSTEMS</b>	REVISION DATE: 10/2013

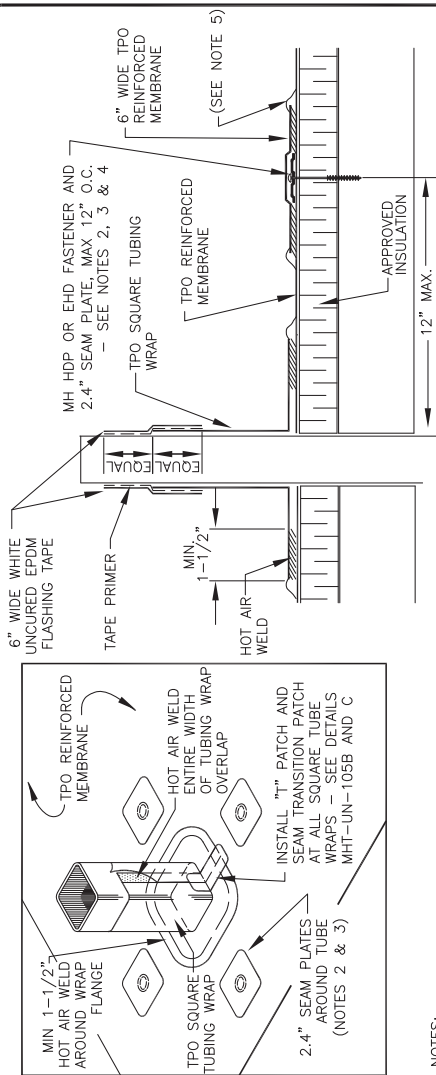

NOTES:

1. REMOVE ALL LEAD AND OTHER FLASHING BEFORE INSTALLING FIELD FABRICATED PIPE SEAL.
2. ON MECHANICALLY FASTENED SYSTEMS, INSTALL A MINIMUM OF FOUR (4) 2.4" SEAM PLATES AROUND PROJECTIONS WITH A DIMENSION UP TO 6". ADDITIONAL SEAM PLATES WILL BE REQUIRED FOR PROJECTIONS WITH DIAMETERS GREATER THAN 6" AND SHALL BE SPACED 12" ON CENTER MAX.
3. FASTENERS AND SEAM PLATES ARE NOT REQUIRED ON ADHERED SYSTEMS UNLESS PROJECTION DIAMETER EXCEEDS 18".
4. PLATES MAY BE POSITIONED INSIDE (OR BELOW) THE PIPE FLASHING FLANGE AS SHOWN ON DETAIL MHT-UN-521C.
5. APPROXIMATELY 1/8" DIAMETER BEAD OF CUT-EDGE SEALANT IS REQUIRED ON CUT EDGES OF TPO REINFORCED MEMBRANE.
6. SQUARE TUBING WRAP IS NOT TO BE USED AS A PITCH PAN.

PREFABRICATED SQUARE TUBING WRAP

DETAIL NO.:

**MHT-UN-528**

REVISION DATE: 1/2016

SYSTEMS:

ALL TPO SYSTEMS

**MULE-HIDE  
PRODUCTS CO., INC.**



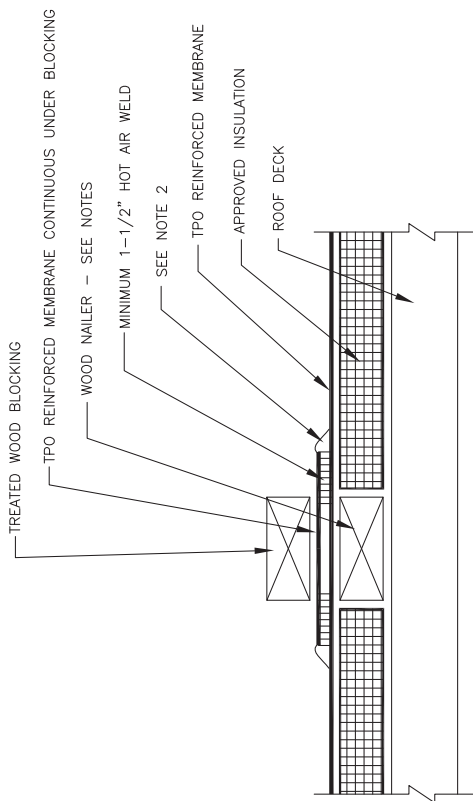

NOTES:

1. IF THE INSULATION COMPRESSIVE STRENGTH IS INSUFFICIENT FOR THE EQUIPMENT WEIGHT, INSTALL WOOD NAILERS UNDER THE EQUIPMENT CARRYING SLEEPER, MATCHING THE HEIGHT OF THE INSULATION.
2. APPROXIMATELY 1/8" DIAMETER BEAD OF CUT-EDGE SEALANT IS REQUIRED ON CUT EDGES OF TPO REINFORCED MEMBRANE.

WOOD SLEEPER  
SYSTEMS:  
ALL TPO SYSTEMS

DETAIL NO.:  
**MHT-UN-530**  
REVISION DATE: 10/2013

**MULE-HIDE  
PRODUCTS CO., INC.**

NOTES:

1. POSITION SEAM PLATES  $1/2"$  TO  $1"$  FROM EDGE OF DECK MEMBRANE.
2. APPROXIMATELY  $1/8"$  DIAMETER BEAD OF CUT-EDGE SEALANT IS REQUIRED ON CUT EDGES OF TPO REINFORCED MEMBRANE.
3. SLEEPER HEIGHT SHOULD BE SUFFICIENT TO ELEVATE THE EQUIPMENT SUPPORT BRACKET ABOVE THE WATER LINE.
4. SLEEPER SHALL BE FULLY FLASHED TO COMPLETELY SEAL SLEEPER

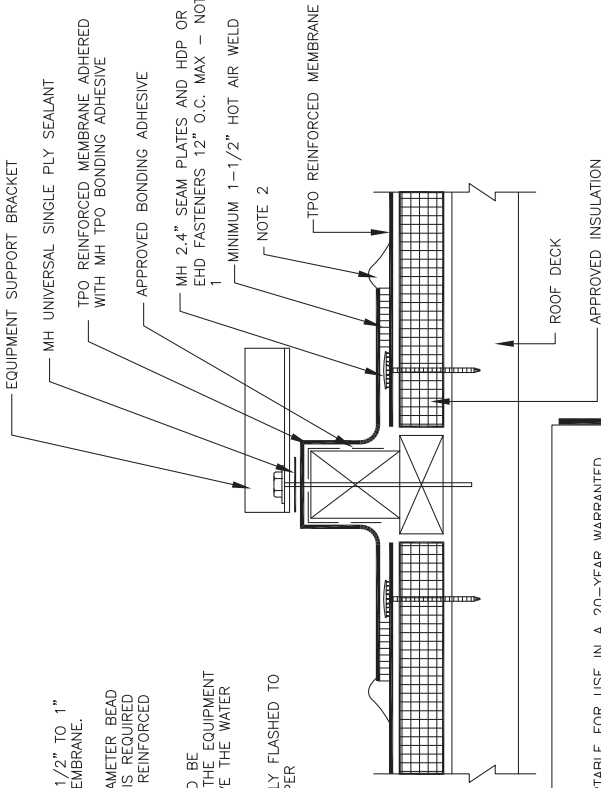

NOTE:

THIS DETAIL IS NOT ACCEPTABLE FOR USE IN A 20-YEAR WARRANTED SYSTEM.

FOR A 20-YEAR WARRANTED SYSTEM INSTALL UNIT ON RAISED PLATFORM WITH SUPPORTS FLASHED AS SHOWN IN DETAIL MHT-UN-521C.

**MULE-HIDE  
PRODUCTS CO., INC.**

FIXED EQUIPMENT SUPPORT

SYSTEMS:  
ALL TPO SYSTEMS

DETAIL NO.:

**MHT-UN-531**

REVISION DATE: 10/2013

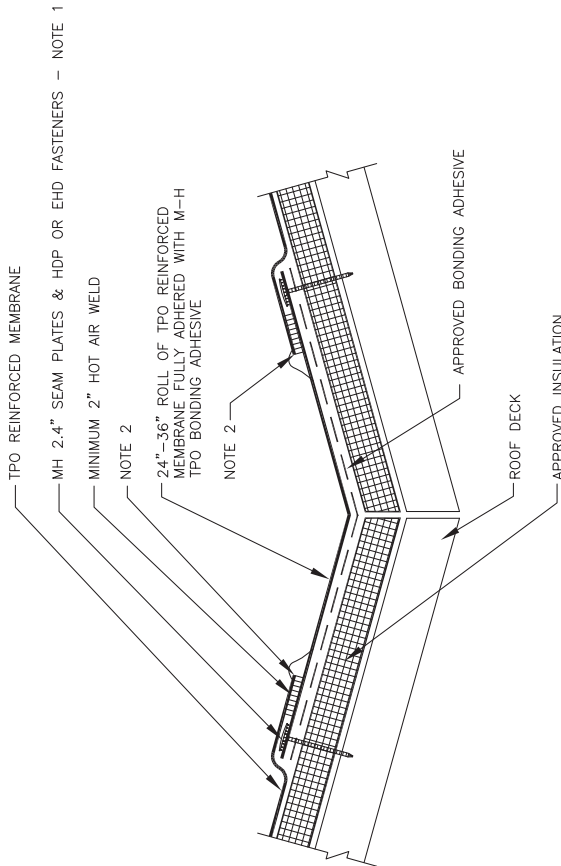

NOTES:

- MEMBRANE FASTENER SPACING NOT TO EXCEED 12" O.C.
- APPROXIMATELY 1/8" DIAMETER BEAD OF CUT-EDGE SEALANT IS REQUIRED ON CUT EDGES OF TPO REINFORCED MEMBRANE.

NOTE:  
THIS DETAIL IS ACCEPTABLE FOR USE IN A  
20-YEAR WARRANTED SYSTEM

VALLEY FLASHING

SYSTEMS:  
MECHANICALLY ATTACHED

DETAIL NO.:

**MHT-MA-601A**

REVISION DATE: 10/2013

**MULE-HIDE  
PRODUCTS CO., INC.**

6" RUSS INSTALLED ON ONE SIDE OF VALLEY. IF A SEAM IS WITHIN 48" OF THE VALLEY, PLACE RUSS ON SIDE OF VALLEY OPPOSITE OF SEAM - MUST USE TAPE PRIMER WITH RUSS - NOTE 3

MH 2.4" SEAM PLATES AND HDP OR EHD FASTENERS 12" O.C. MAX - NOTE 1

TPO REINFORCED MEMBRANE

NOTE 2

MINIMUM 2" HOT AIR WELD

MH 2.4" SEAM PLATES AND HDP OR EHD FASTENERS 12" O.C. MAX - NOTE 1

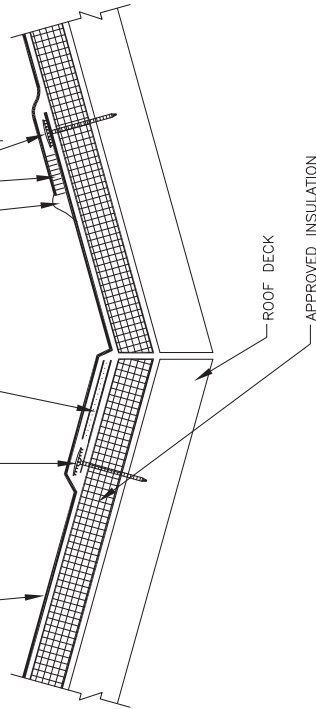

NOTES:

- MEMBRANE FASTENER SPACING NOT TO EXCEED 12" O.C.
- APPROXIMATELY 1/8" DIAMETER BEAD OF CUT-EDGE SEALANT IS REQUIRED ON CUT EDGES OF TPO REINFORCED MEMBRANE.
- RUSS PRODUCTS CANNOT BE USED WITH FLEECEBACK OR SELF ADHERING MEMBRANES.

NOTE:  
THIS DETAIL IS ACCEPTABLE FOR USE IN A 20-YEAR WARRANTED SYSTEM

**MULE-HIDE PRODUCTS CO., INC.**

**VALLEY FLASHING  
6" RUSS  
SYSTEMS:  
MECHANICALLY ATTACHED**

**DETAIL NO.:**  
**MHT-MA-601B**  
REVISION DATE: 10/2013

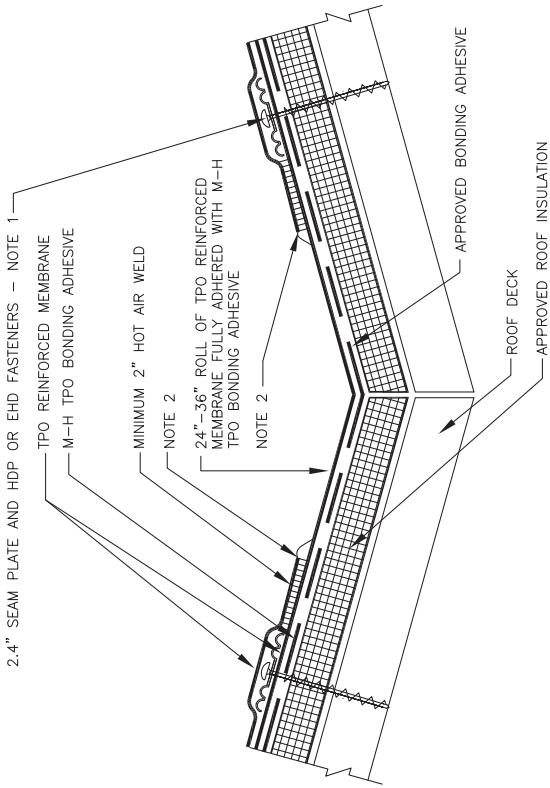

NOTES:

1. MEMBRANE FASTENER SPACING NOT TO EXCEED 12" O.C.
2. APPROXIMATELY 1/8" DIAMETER BEAD OF CUT-EDGE SEALANT IS REQUIRED ON CUT EDGES OF TPO REINFORCED MEMBRANE.

NOTE:  
THIS DETAIL IS ACCEPTABLE FOR USE IN A  
20-YEAR WARRANTED SYSTEM

<p><b>MULE-HIDE PRODUCTS CO., INC.</b></p>	<p><b>VALLEY FLASHING</b></p>
<p><b>SYSTEMS: FULLY ADHERED</b></p>	
<p><b>DETAIL NO.: MHT-FA-601C</b></p>	
<p>REVISION DATE: 10/2013</p>	

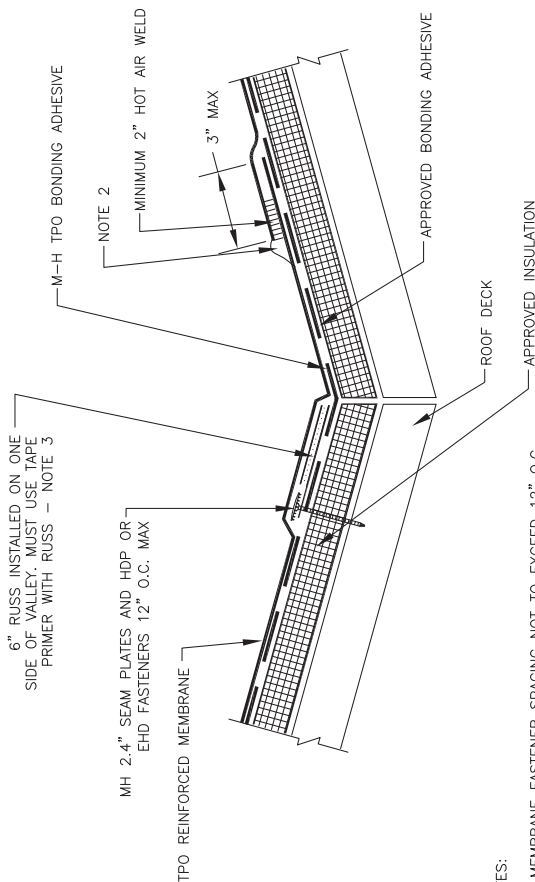

6" RUSS INSTALLED ON ONE SIDE OF VALLEY. MUST USE TAPE PRIMER WITH RUSS - NOTE 3

MH 2.4" SEAM PLATES AND HDP OR EHD FASTENERS 12" O.C. MAX

TPO REINFORCED MEMBRANE

M-H TPO BONDING ADHESIVE

NOTE 2

MINIMUM 2" HOT AIR WELD

3" MAX

APPROVED BONDING ADHESIVE

ROOF DECK

APPROVED INSULATION

NOTES:

1. MEMBRANE FASTENER SPACING NOT TO EXCEED 12" O.C.
2. APPROXIMATELY 1/8" DIAMETER BEAD OF CUT-EDGE SEALANT IS REQUIRED ON CUT EDGES OF TPO REINFORCED MEMBRANE.
3. RUSS PRODUCTS CANNOT BE USED WITH FLEECEBACK OR SELF ADHERING MEMBRANES.

NOTE:

THIS DETAIL IS ACCEPTABLE FOR USE IN A 20-YEAR WARRANTED SYSTEM

VALLEY FLASHING  
6" RUSS

SYSTEMS:  
FULLY ADHERED

DETAIL NO.:

**MHT-FA-601D**

REVISION DATE: 10/2013

**MULE-HIDE  
PRODUCTS CO., INC.**

TPO REINFORCED  
MEMBRANE, NOT EXCEEDING  
5" IN WIDTH, SHALL  
BE APPROX. CENTERED  
OVER RIDGE

TPO REINFORCED  
MEMBRANE

APPROX. 5-1/2" WIDE  
MEMBRANE OVERLAP, HOT AIR  
WELDED MINIMUM 2"  
BEYOND SEAM PLATES  
(REFER TO DETAIL MHT-MA-104A)

MULE-HIDE HDPE OR EHD  
FASTENER AND 2.4" SEAM  
PLATE (NOTES 2 & 4)

NOTES

1. RIDGE MEMBRANE ATTACHMENT IS ONLY REQUIRED WHEN ROOF SLOPE EXCEEDS 1-1/2" TO ONE HORIZONTAL FOOT.
2. POSITION 2.4" SEAM PLATES 1/2" MINIMUM TO 1" MAXIMUM FROM THE EDGE OF THE DECK MEMBRANE.
3. APPROXIMATELY 1/8" DIAMETER BEAD OF CUT-EDGE SEALANT IS REQUIRED ON CUT EDGES OF TPO REINFORCED MEMBRANE.
4. REFER TO SPECIFICATION FOR ACCEPTABLE MULE-HIDE FASTENERS AND FASTENING DENSITY.

APPROVED INSULATION

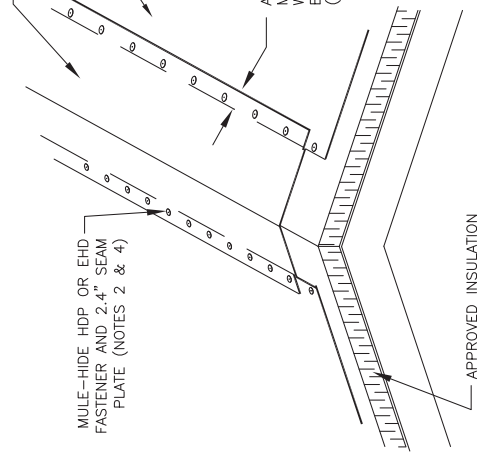

RIDGE SHEET LAYOUT

DETAIL NO.:

**MHT-MA-602A**

REVISION DATE: 10/2013

SYSTEMS:

MECHANICALLY ATTACHED

**MULE-HIDE  
PRODUCTS CO., INC.**

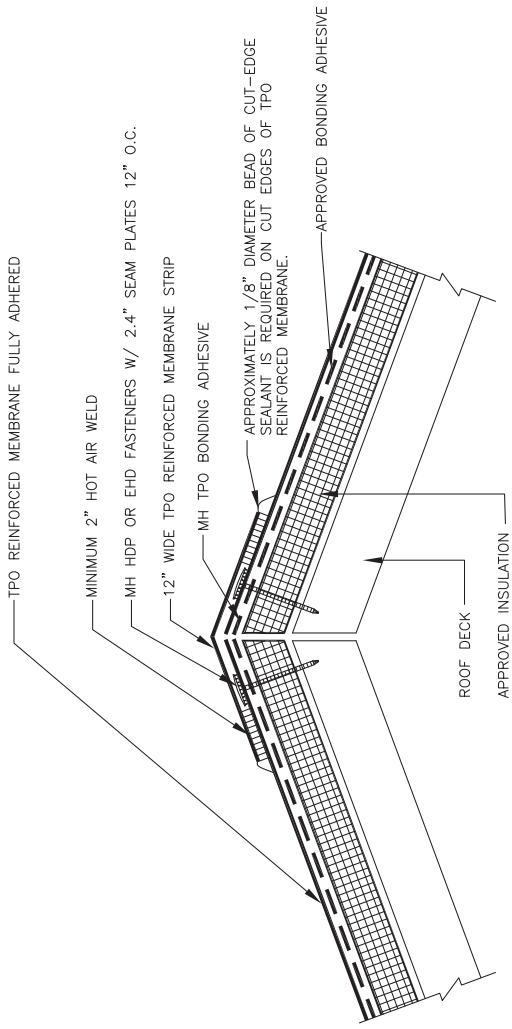

NOTES:

MEMBRANE FASTENER SPACING NOT TO EXCEED 12" O.C.

<b>MULE-HIDE PRODUCTS CO., INC.</b>	<b>RIDGE FLASHING</b>	<b>DETAIL NO.:</b> <b>MHT-FA-602B</b>
	<b>SYSTEMS:</b> <b>FULLY ADHERED</b>	REVISION DATE: 10/2013



NOTES:

1. POSITION SEAM PLATES 1/2" TO 1" FROM EDGE OF DECK MEMBRANE.
2. APPROXIMATELY 1/8" DIAMETER BEAD OF CUT-EDGE SEALANT IS REQUIRED ON CUT EDGES OF TPO REINFORCED MEMBRANE.

NOTE:

THIS DETAIL ONLY INSTALLED WHEN CURB IS PARALLEL TO ROOF SLOPE.

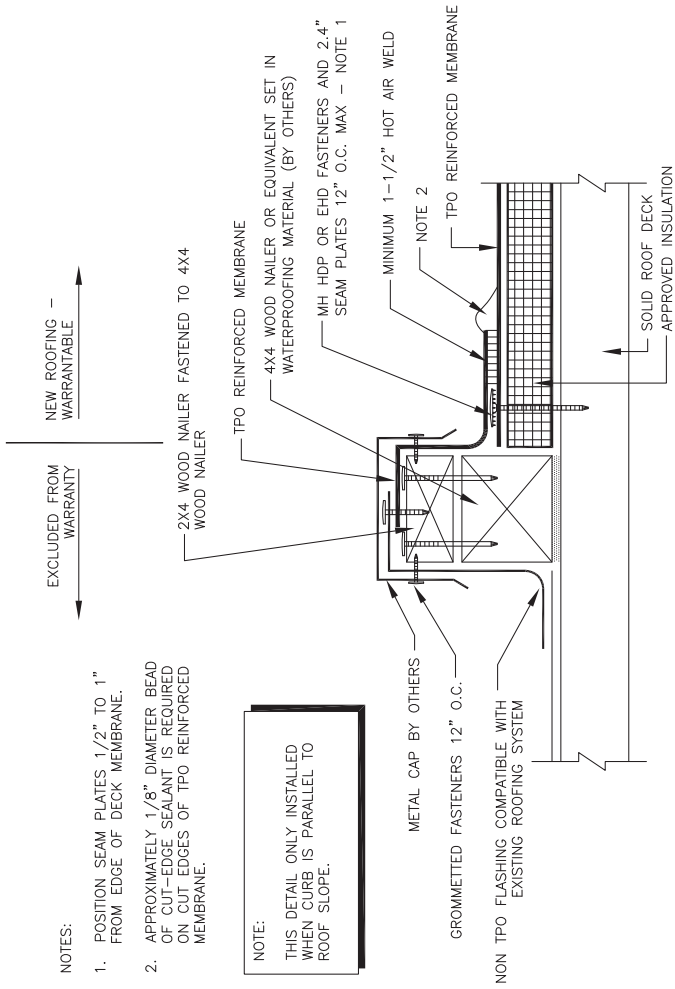

TIE-IN TO SOLID DECK WITH CURB  
CURB PARALLEL TO SLOPE WITH TEAR OFF  
SYSTEMS:

ALL TPO SYSTEMS

DETAIL NO.:

**MHT-UN-609**

REVISION DATE: 10/2013

**MULE-HIDE  
PRODUCTS CO., INC.**

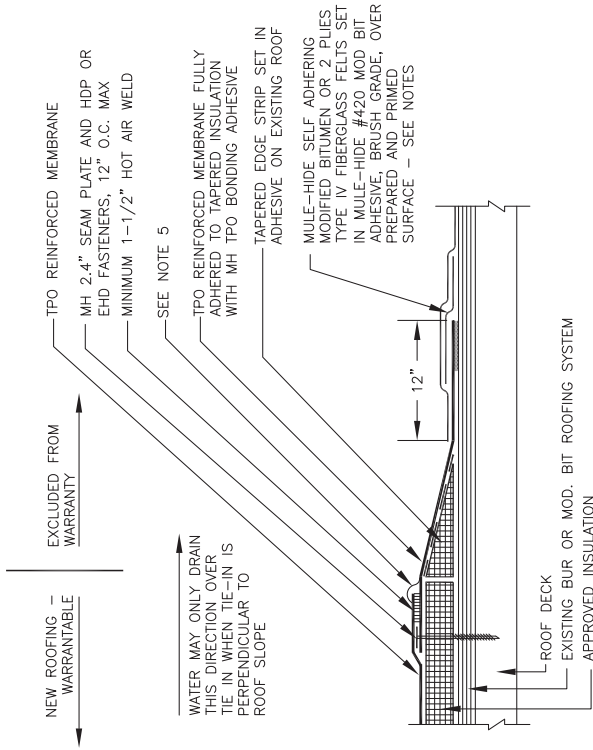

**NOTES:**

1. CLEAN AND PRIME AN 18" WIDE STRIP OF THE EXISTING ROOF SURFACE.
2. SET TPO REINFORCED MEMBRANE IN MULE-HIDE #420 MOD BIT ADHESIVE, BRUSH GRADE ON TOP OF EXISTING BUILT UP ROOFING.
3. USE ONE PLY OF MULE-HIDE SA BASE AND ONE PLY OF MULE-HIDE SA CAP SHEET TO PRIME SURFACE OR SET 2 PLYS OF TYPE VI FIBERGLASS FELTS IN LAYERS OF MULE-HIDE #420 MOD BIT ADHESIVE, BRUSH GRADE. BOTTOM LAYER - 9" WIDE AND TOP LAYER - 12" WIDE (MIN).
4. COAT SURFACE WITH MULE-HIDE #102 FIBRATED ROOF COATING.
5. APPROXIMATELY 1/8" DIAMETER BEAD OF CUT-EDGE SEALANT IS REQUIRED ON CUT EDGES OF TPO REINFORCED MEMBRANE.

<p><b>MULE-HIDE PRODUCTS CO., INC.</b></p>	<p><b>TIE-IN TO EXISTING BUR / MOD BIT ROOF RECOVER SITUATION SYSTEMS: ALL TPO SYSTEMS</b></p>
<p><b>DETAIL NO.: MHT-UN-610A</b></p> <p>REVISION DATE: 10/2013</p>	

NEW ROOFING —  
WARRANTABLE

EXCLUDED FROM  
WARRANTY

WATER CAN FLOW EITHER  
DIRECTION OVER TIE-IN

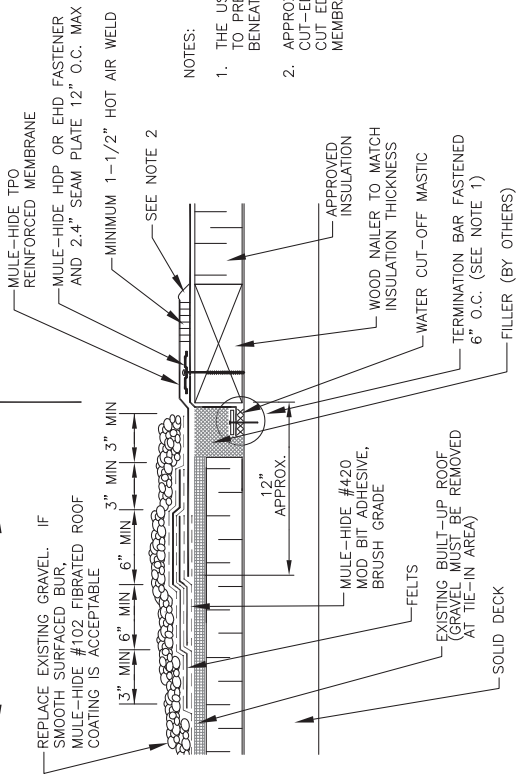

NOTES:

1. THE USE OF THE TERMINATION BAR IS TO PREVENT MIGRATION OF WATER BENEATH THE TPO ROOFING SYSTEM.
2. APPROXIMATELY 1/8" DIAMETER BEAD OF CUT-EDGE SEALANT IS REQUIRED ON CUT EDGES OF TPO REINFORCED MEMBRANE.

TIE-IN EXISTING BUR OR MOD. BIT.

SYSTEMS:  
ALL TPO SYSTEMS

DETAIL NO.:

**MHT-UN-610B**

REVISION DATE: 10/2013

**MULE-HIDE  
PRODUCTS CO., INC.**

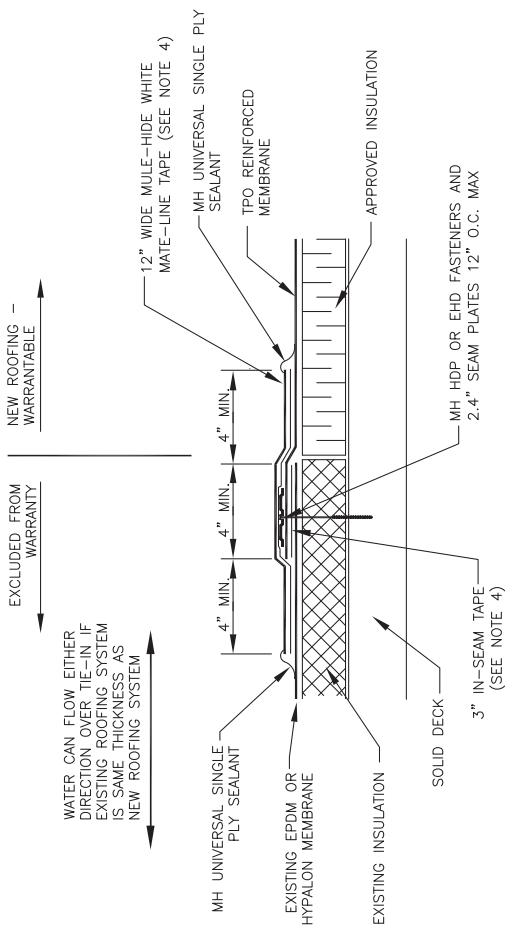

NOTES:

1. REFER TO SPECIFICATION FOR ACCEPTABLE MULE-HIDE FASTENERS AND PLATES.
2. REFER TO MULE-HIDE'S EPDM SPECIFICATIONS FOR SURFACE PREPARATION PROCEDURES FOR EXISTING MEMBRANE.
3. PRIOR TO SEAMING APPLICATION, USE WEATHERED MEMBRANE CLEANER TO PREPARE SURFACES OF TPO AND CLEANED EPDM OR HYPALON MEMBRANES.
4. MULE-HIDE TAPE PRIMER MUST BE USED TO PREPARE MEMBRANE SURFACES PRIOR TO APPLYING MULE-HIDE WHITE MATE-LINE TAPE, IN-SEAM TAPE, AND UNIVERSAL SINGLE PLY SEALANT.

**TIE-IN TO EXISTING EPDM OR HYPALON  
TEAR-OFF SITUATION  
SYSTEMS:**

ALL TPO SYSTEMS

DETAIL NO.:

**MHT-UN-610C**

REVISION DATE: 10/2013

**MULE-HIDE  
PRODUCTS CO., INC.**

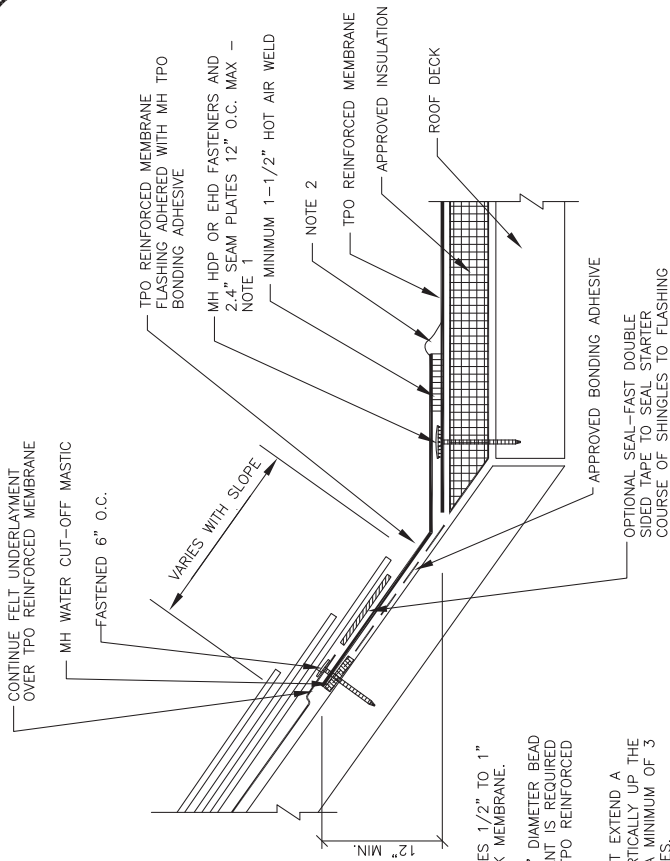

NOTES:

1. POSITION SEAM PLATES 1/2" TO 1" FROM EDGE OF DECK MEMBRANE.
2. APPROXIMATELY 1/8" DIAMETER BEAD OF CUT-EDGE SEALANT IS REQUIRED ON CUT EDGES OF TPO REINFORCED MEMBRANE.
3. TPO MEMBRANE MUST EXTEND A MINIMUM OF 12" VERTICALLY UP THE SLOPE AND UNDER A MINIMUM OF 3 COURSES OF SHINGLES.

**TIE-IN SHINGLE ROOF**

**SYSTEMS:**  
ALL TPO SYSTEMS

**DETAIL NO.:**

**MHT-UN-611A**

REVISION DATE: 10/2016

**MULE-HIDE  
PRODUCTS CO., INC.**

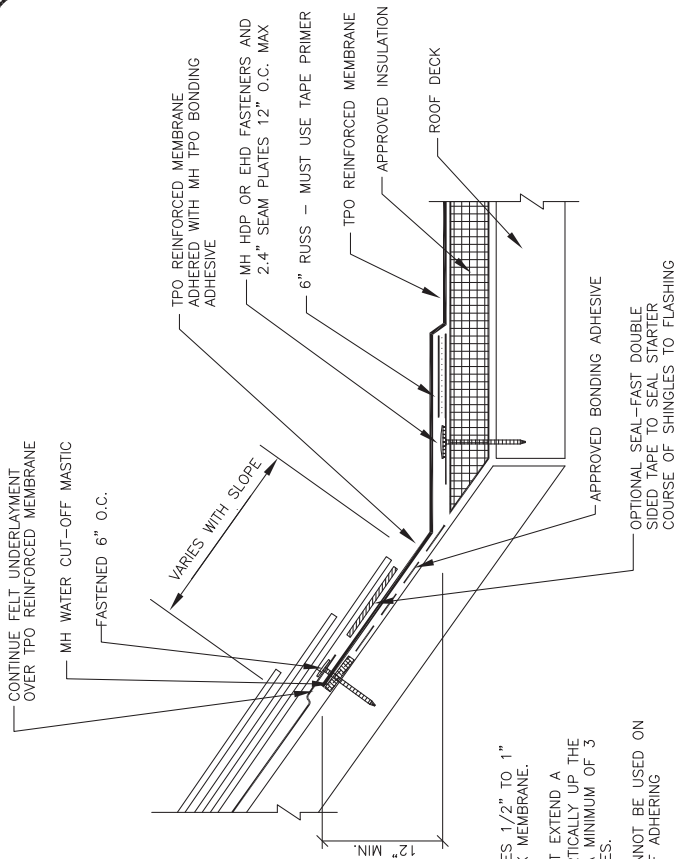

NOTES:

1. POSITION SEAM PLATES 1/2" TO 1" FROM EDGE OF DECK MEMBRANE.
2. TPO MEMBRANE MUST EXTEND A MINIMUM OF 12" VERTICALLY UP THE SLOPE AND UNDER A MINIMUM OF 3 COURSES OF SHINGLES.
3. RUSS PRODUCTS CANNOT BE USED ON FLEECEBACK OR SELF ADHERING MEMBRANES.

<b>MULE-HIDE PRODUCTS CO., INC.</b>	<b>TIE-IN SHINGLE ROOF 6" RUSS SYSTEMS:</b> ALL TPO SYSTEMS	<b>DETAIL NO.:</b> <b>MHT-UN-611B</b> REVISION DATE: 10/2016

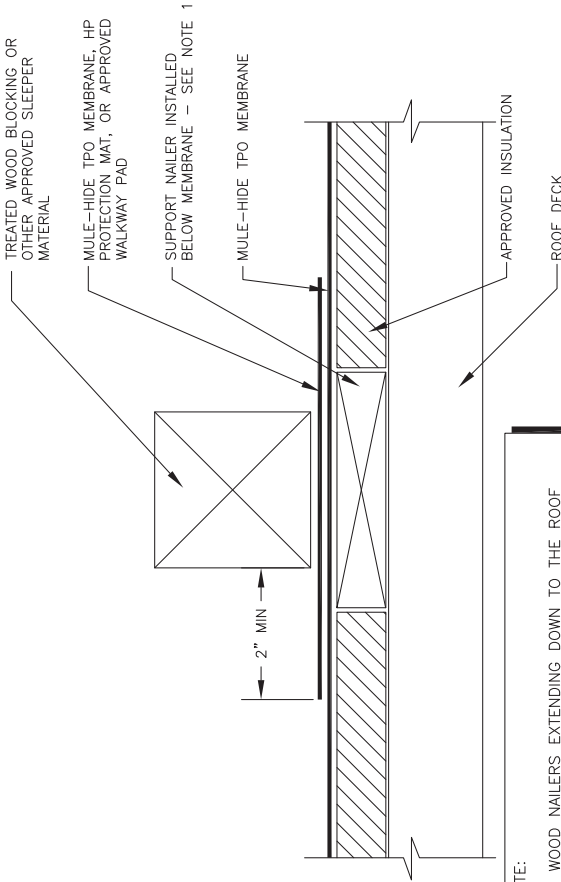

NOTE:

- WOOD NAILERS EXTENDING DOWN TO THE ROOF DECK ARE REQUIRED BELOW THE MEMBRANE WHEN THE ANTICIPATED WEIGHT PER SQUARE INCH (PSI) OF THE UNIT EXCEEDS 80% OF THE RATED COMPRESSIVE STRENGTH OF THE ROOF INSULATION.

DETAIL NO.:  
**MHT-JUN-620**  
 REVISION DATE: 03/2017

SLEEPER  
 DETAIL  
 SYSTEMS:  
 ALL TPO SYSTEMS

**MULE-HIDE  
 PRODUCTS CO., INC.**

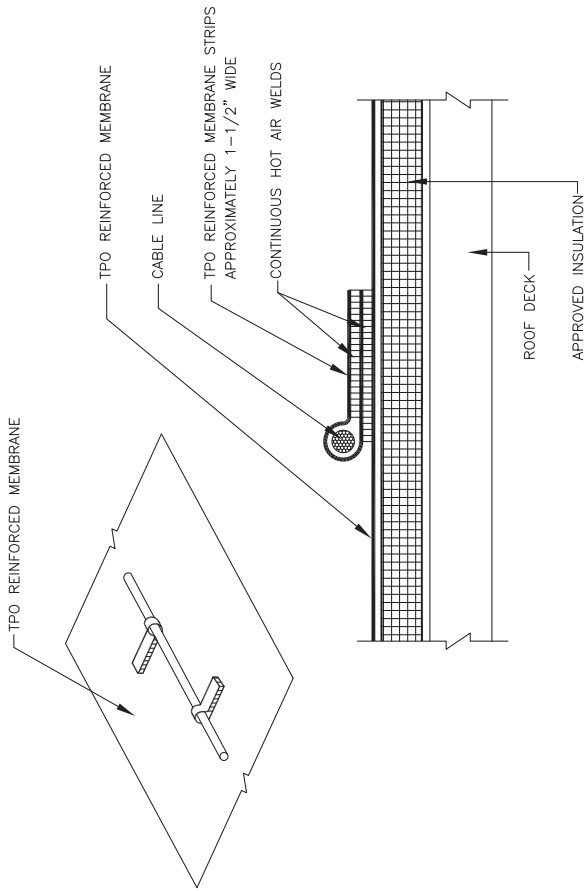

<b>MULE-HIDE PRODUCTS CO., INC.</b>	<b>LIGHTNING CABLE STRAP</b>	<b>DETAIL NO.:</b> <b>MHT-UN-621</b>
	<b>SYSTEMS:</b> <b>ALL TPO SYSTEMS</b>	REVISION DATE: 10/2013



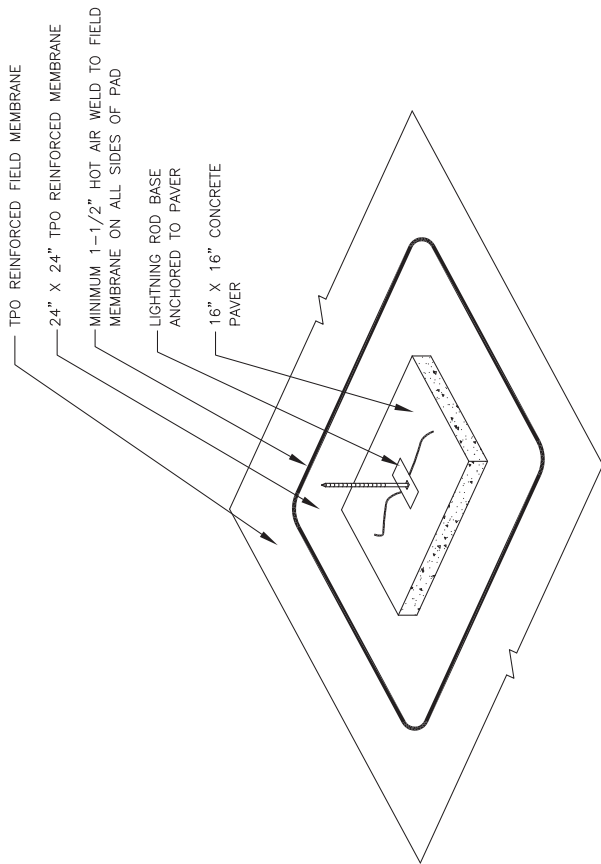

LIGHTNING ROD BASE

SYSTEMS:

ALL TPO SYSTEMS

DETAIL NO.:

**MHT-UN-622A**

REVISION DATE: 10/2013

**MULE-HIDE  
PRODUCTS CO., INC.**

NOTES:

1. CLEAN EXPOSED MEMBRANE WITH WEATHERED MEMBRANE CLEANER.
2. APPLY MULE-HIDE TAPE PRIMER TO THE MEMBRANE AND LIGHTNING ROD BASE. ALLOW TO DRY UNTIL IT IS TACK FREE.
3. INSTALL A SECTION OF WHITE IN-SEAM TAPE (APPROXIMATELY THE SIZE OF THE METAL BASE) TO THE MEMBRANE SURFACE. LEAVE THE RELEASE FILM IN PLACE AND ROLL TAPE FROM THE CENTER TO THE OUTER EDGES.
4. REMOVE RELEASE FILM AND CAREFULLY PLACE METAL BASE OVER THE IN-SEAM TAPE.
5. APPLY TAPE PRIMER TO TPO MEMBRANE WHERE UNIVERSAL SINGLE PLY SEALANT IS TO BE APPLIED. ALLOW TO DRY UNTIL TACK FREE. SEAL ALL EDGES AND ANY EXPOSED AREAS OF TAPE (AT PERFORATED BASE) WITH MULE-HIDE UNIVERSAL SINGLE PLY SEALANT.

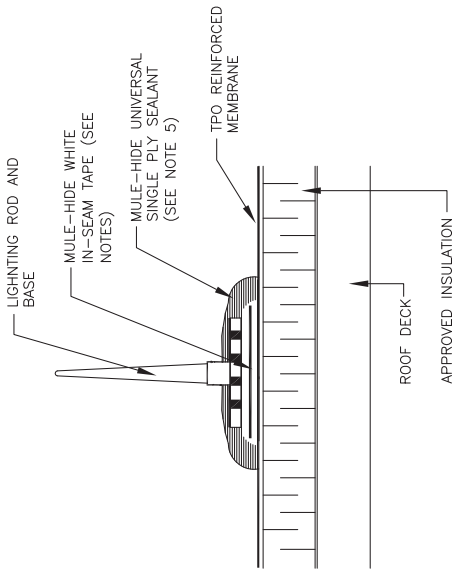

LIGHTNING ROD DETAIL

SYSTEMS:  
ALL TPO SYSTEMS

DETAIL NO.:

**MHT-UN-622B**

REVISION DATE: 10/2013

**MULE-HIDE  
PRODUCTS CO., INC.**

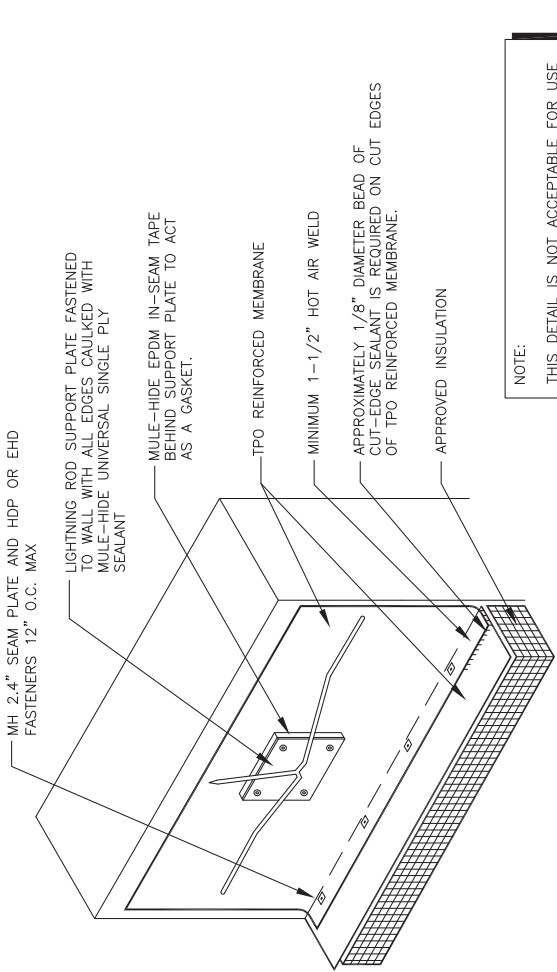

NOTE:  
THIS DETAIL IS NOT ACCEPTABLE FOR USE IN A 20-YEAR WARRANTED SYSTEM

<b>MULE-HIDE PRODUCTS CO., INC.</b>	<b>LIGHTNING ROD WALL SUPPORT SYSTEMS:</b>	<b>DETAIL NO.:</b> <b>MHT-UN-623</b>
	<b>ALL TPO SYSTEMS</b>	REVISION DATE: 10/2013

NOT FOR USE ON 20 YEAR WARRANTY PROJECTS. TERMINATION MUST HAVE COMPRESSION SEAL. SEE ALL OTHER 624 DETAILS

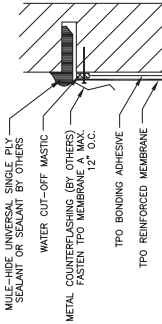

- NOTES:
- COUNTERFLASHING SHALL BE ELEVATED ABOVE PONDED WATER.
  - NOT FOR USE ON 20 YEAR WARRANTY PROJECTS (REFER TO DETAIL 624-B).
  - BONDING ADHESIVE IS NOT REQUIRED WHEN SHEETMETAL IS USED. FASTENERS MUST BE SPACED A MAXIMUM 12" O.C.
  - IF THE SHEETMETAL IS TO BE INCLUDED IN THE WARRANTY, CONTRACTOR MUST USE SHEETMETAL PRODUCTS REFER TO DETAILS MHSM-6130, MHSM-6145, OR MHSM-6146.

624-A COUNTERFLASHING TERMINATION

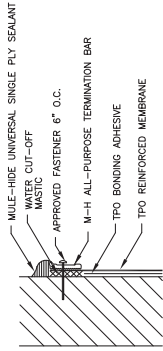

- FOR USE ON 20 YEAR WARRANTY PROJECTS.
- ALLOW 1/4" TO 1/2" SPACING BETWEEN CONSECUTIVE LENGTHS OF TERMINATION BAR.
- BONDING ADHESIVE IS NOT REQUIRED WHEN FLASHING IS 18" OR LESS.

624-C MECHANICAL TERMINATION

FOR USE ON 20 YEAR WARRANTY PROJECTS. TERMINATION BAR IS NOT REQUIRED ON 10 YEAR WARRANTY PROJECTS (REFER TO DETAIL 624-A)

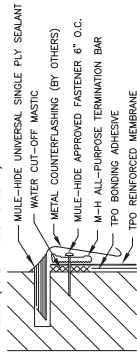

- APPLY ON HARD SMOOTH SURFACE ONLY; NOT FOR USE ON ROOF.
- DO NOT WRAP COMPRESSION TERMINATION AROUND CORNERS.
- FASTENERS OF METAL BAR MUST PROVIDE CONSTANT COMPRESSION ON WATER CUT-OFF MASTIC.
- BONDING ADHESIVE IS NOT REQUIRED WHEN FLASHING IS 18" OR LESS.
- IF THE SHEETMETAL IS TO BE INCLUDED IN THE WARRANTY, CONTRACTOR MUST USE MULE-HIDE METAL PRODUCTS. REFER TO DETAILS MHSM-6130, MHSM-6145, OR MHSM-6146.

624-D COPING STONE TERMINATION

FOR USE ON 20 YEAR WARRANTY PROJECTS.

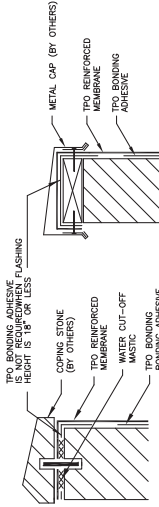

624-E CAP FLASHING TERMINATION

NOTES:  
IF THE SHEETMETAL IS TO BE INCLUDED IN THE WARRANTY, CONTRACTOR MUST USE MULE-HIDE METAL PRODUCTS. REFER TO DETAILS MHSM-6054A, B, OR MHSM-6056.

TERMINATION DETAILS

SYSTEMS:  
ALL TPO SYSTEMS

DETAIL NO.:  
**MHT-UN-624**  
REVISION DATE: 10/2013

**MULE-HIDE  
PRODUCTS CO., INC.**

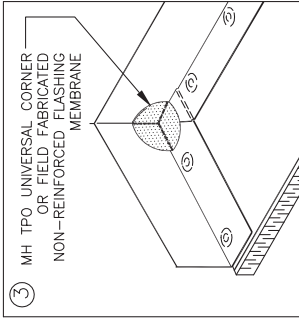
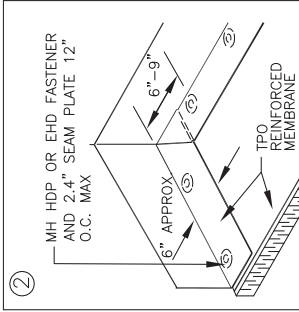
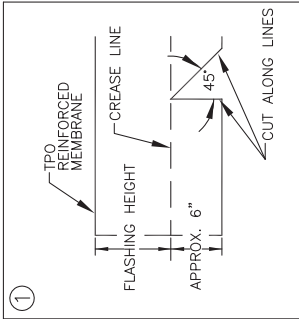

NOTES:

1. BEGIN INSTALLATION OF 2.4" SEAM PLATES 6" TO 9" FROM THE CORNER.
2. POSITION 2.4" SEAM PLATES 1/2" TO 1" FROM EDGE OF TPO REINFORCED MEMBRANE.
3. APPROXIMATELY 1/8" DIAMETER BEAD OF CUT-EDGE SEALANT IS REQUIRED ON CUT EDGES OF TPO REINFORCED MEMBRANE.

INSIDE CORNER

SYSTEMS:

ALL TPO SYSTEMS

DETAIL NO.:

**MHT-UN-640A**

REVISION DATE: 10/2013

**MULE-HIDE  
PRODUCTS CO., INC.**

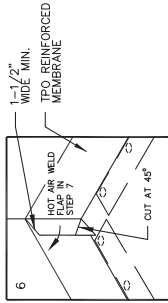
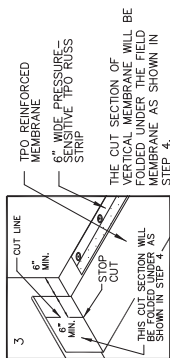
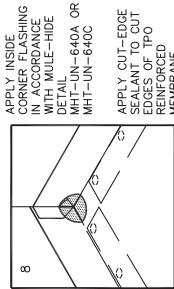
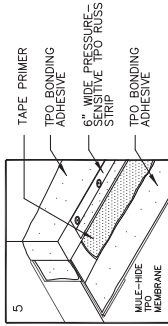
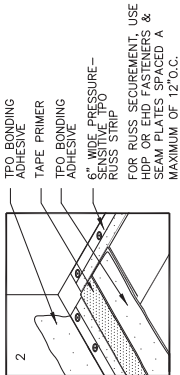
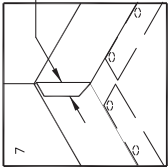
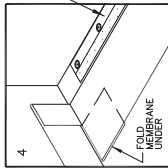
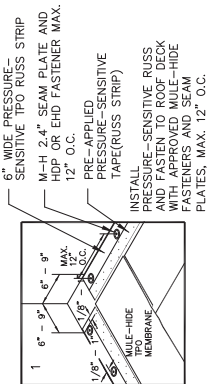

NOTE:  
 RUSS PRODUCTS CANNOT BE USED WITH FLEECEBACK OR SELF ADHERING MEMBRANES.

**MULE-HIDE PRODUCTS CO., INC.**

INSIDE CORNER USING RUSS SYSTEMS:  
 ALL TPO SYSTEMS

DETAIL NO.:  
**MHT-UN-640B**  
 REVISION DATE: 10/2013

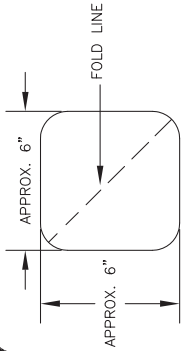

① CUT A SECTION OF TPO NON-REINFORCED FLASHING WITH ROUNDED CORNERS OR USE UNIVERSAL CORNER; FOLD ALONG LINE AS INDICATED.

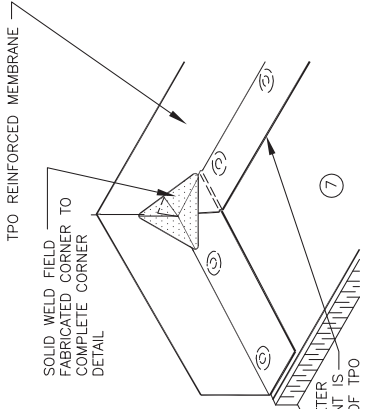
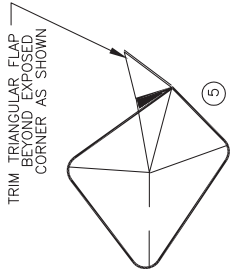
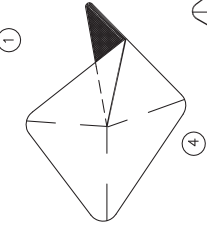
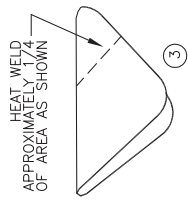
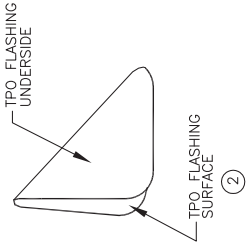

⑥ POSITION AND HEAT WELD CORNER IN PLACE AS SHOWN

**FIELD FABRICATED INSIDE CORNER**

**DETAIL NO.:**  
**MHT-UN-640C**  
 REVISION DATE: 10/2013

**SYSTEMS:**  
 ALL TPO SYSTEMS

**MULE-HIDE PRODUCTS CO., INC.**

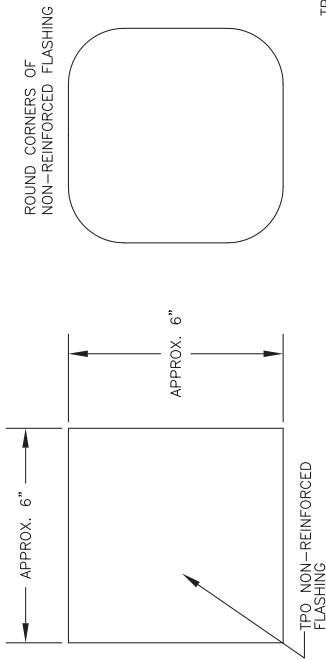

ROUND CORNERS OF  
NON-REINFORCED FLASHING

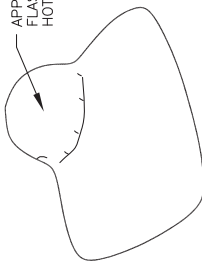

APPLY HEAT TO TPO NON-REINFORCED FLASHING AND FORM BY HAND PRIOR TO HOT AIR WELDING CORNER IN PLACE.

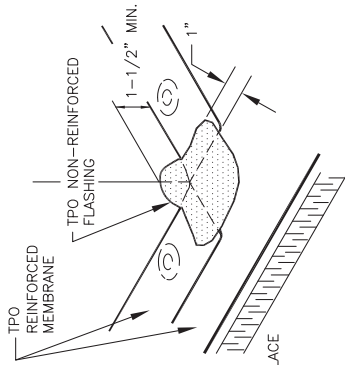

POSITION AND HEAT  
WELD CORNER IN PLACE  
AS SHOWN

FIELD FABRICATED  
OUTSIDE CORNER  
SYSTEMS:

ALL TPO SYSTEMS

DETAIL NO.:

**MHT-UN-641A**

REVISION DATE: 10/2013

**MULE-HIDE  
PRODUCTS CO., INC.**



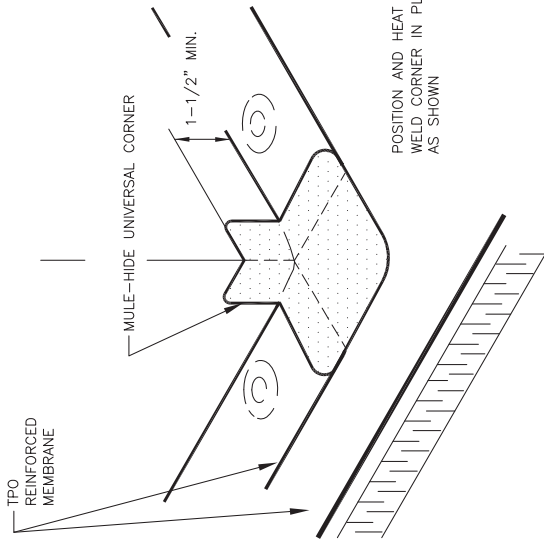

POSITION AND HEAT  
WELD CORNER IN PLACE  
AS SHOWN

TPO UNIVERSAL CORNER  
OUTSIDE CORNER  
SYSTEMS:

ALL TPO SYSTEMS

DETAIL NO.:

**MHT-UN-641B**

REVISION DATE: 10/2013

**MULE-HIDE  
PRODUCTS CO., INC.**

FASTENING PATTERNS FOR EXTRUDED POLYSTYRENE INSULATION FOR USE DIRECTLY UNDER MECHANICALLY ATTACHED WHITE TPO REINFORCED MEMBRANE ONLY

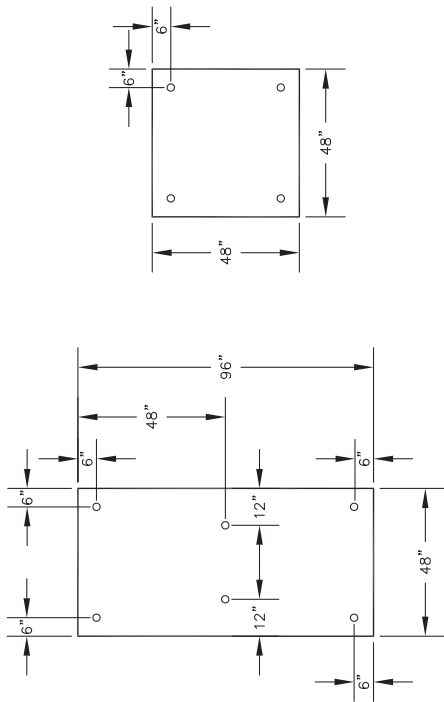

NOTES:

1. MULE-HIDE 3" METAL STRESS PLATES MUST BE USED WITH MULE-HIDE FASTENERS FOR INSULATION ATTACHMENT.
2. FASTENER TOLERANCE SHALL BE  $\pm 1$  INCH.

<b>MULE-HIDE PRODUCTS CO., INC.</b>	<b>EXTRUDED POLYSTYRENE INSULATION ATTACHMENT FASTENING PATTERNS SYSTEMS:</b>	<b>DETAIL NO.:</b> <b>MHT-MA-700</b>
	<b>MECHANICALLY ATTACHED</b>	REVISION DATE: 10/2013

2" OR THICKER POLYISOCYANURATE INSULATION ONLY

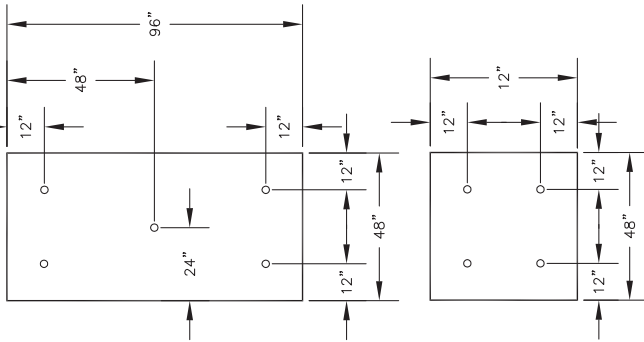

ALL OTHER INSULATIONS

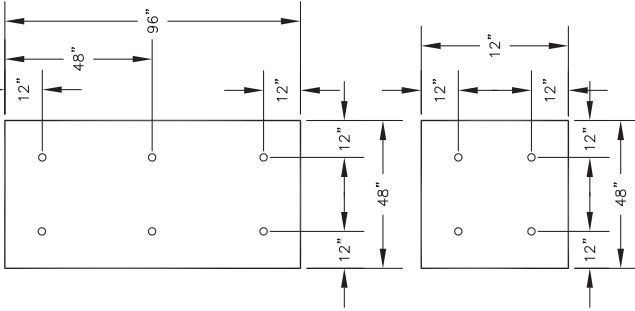

NOTES:

1. MULE-HIDE 3" METAL STRESS PLATES MUST BE USED WITH MULE-HIDE FASTENERS FOR INSULATION ATTACHMENT.
2. FASTENER TOLERANCE SHALL BE +1 INCH.

INSULATION ATTACHMENT PATTERNS

SYSTEMS:  
MECHANICALLY ATTACHED

DETAIL NO.:

**MHT-MA-701**

REVISION DATE: 10/2013

**MULE-HIDE  
PRODUCTS CO., INC.**

NOTES:

1. 8 FASTENERS PER 4' X 8' BOARDS (1 FASTENER EVERY 4 SQUARE FEET) IN THE FIELD IS APPROVED FOR INSULATIONS 2" OR MORE THICK WHEN USED AS THE TOP LAYER.
2. PERIMETER AND CORNER DIMENSIONS ARE TO BE A MINIMUM OF 8" WIDE UNLESS THE PROJECT REQUIRES FACTORY MUTUAL COMPLIANCE. CONTACT MULE-HIDE TECHNICAL DEPARTMENT FOR FACTORY MUTUAL REQUIREMENTS.
3. MULE-HIDE FASTENERS AND 3" STRESS PLATES MUST BE USED FOR INSULATION ATTACHMENT.
4. REFER TO MULE-HIDE WIND UPLIFT RATINGS FOR APPROPRIATE FASTENER DENSITY REQUIRED.
5. FASTENER DENSITY INCREASES BASED ON THE FOLLOWING:
  - 50% FOR PERIMETERS
  - 100% FOR CORNERS

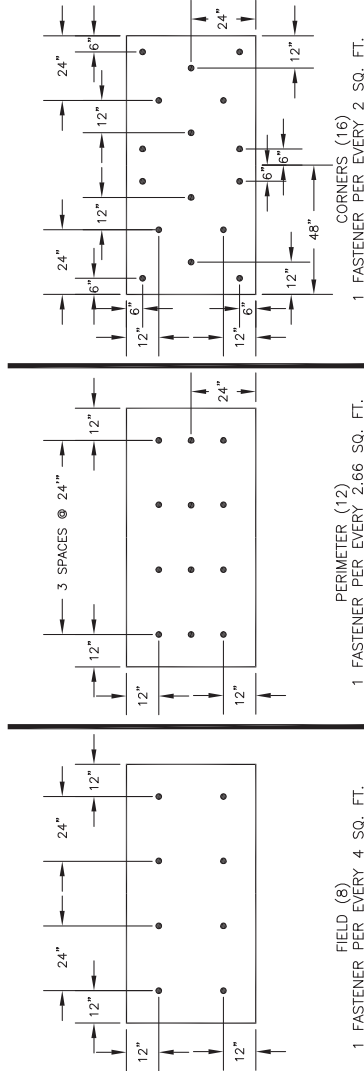

2" OR THICKER INSULATION ATTACHMENT  
8 FASTENERS PER 4' X 8' IN FIELD

SYSTEMS:  
FULLY ADHERED

DETAIL NO.:  
**MHT-FA-720**  
REVISION DATE: 10/2013

**MULE-HIDE  
PRODUCTS CO., INC.**

NOTES:

- 12 FASTENERS PER 4' X 8' BOARD IN THE FIELD IS APPROVED FOR 1-1/2" TO 2" THICK POLYISOCYANURATE INSULATIONS WHEN USED AS THE TOP LAYER OR 1/4" DENS DECK INSTALLED AS A COVER BOARD.
- PERIMETER AND CORNER DIMENSIONS ARE TO BE A MINIMUM OF 8" WIDE UNLESS THE PROJECT REQUIRES FACTORY MUTUAL COMPLIANCE. CONTACT MULE-HIDE TECHNICAL DEPARTMENT FOR FACTORY MUTUAL REQUIREMENTS.
- MULE-HIDE FASTENERS AND 3" STRESS PLATES MUST BE USED FOR INSULATION ATTACHMENT.
- REFER TO MULE-HIDE WIND UPLIFT RATINGS FOR APPROPRIATE FASTENER DENSITY REQUIRED.
- FASTENER DENSITY INCREASES BASED ON THE FOLLOWING:
  - 50% FOR PERIMETERS
  - 100% FOR CORNERS

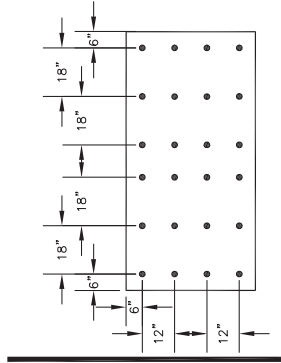
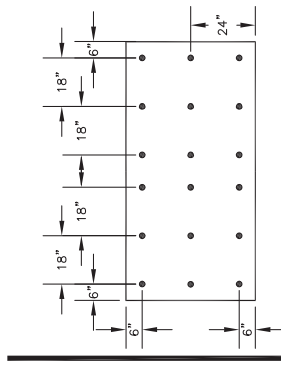
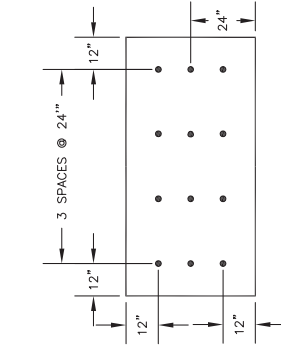

FIELD (12)  
PER EVERY 2.66 SQ. FT.

PERIMETER (18)  
FASTENER PER EVERY 1.77 SQ. FT.

CORNERS (24)  
FASTENER PER EVERY 1.33 SQ. FT.

INSULATION ATTACHMENT  
12 FASTENERS PER 4' X 8' IN FIELD  
SYSTEMS:

DETAIL NO.:

**MHT-FA-721**

REVISION DATE: 10/2013

**MULE-HIDE  
PRODUCTS CO., INC.**

FULLY ADHERED

NOTES:

- 16 FASTENERS PER 4' X 8' BOARD IN THE FIELD IS MULE-HIDE'S STANDARD FOR FULLY ADHERED TPO ROOFING SYSTEMS.
- PERIMETER AND CORNER DIMENSIONS ARE TO BE A MINIMUM OF 8" WIDE UNLESS THE PROJECT REQUIRES FACTORY MUTUAL COMPLIANCE. CONTACT MULE-HIDE TECHNICAL DEPARTMENT FOR FACTORY MUTUAL REQUIREMENTS.
- MULE-HIDE FASTENERS AND 3" STRESS PLATES MUST BE USED FOR INSULATION ATTACHMENT.
- REFER TO MULE-HIDE WIND UPLIFT RATINGS FOR APPROPRIATE FASTENER DENSITY REQUIRED.
- FASTENER DENSITY INCREASES BASED ON THE FOLLOWING:
  - 50% FOR PERIMETERS
  - 100% FOR CORNERS

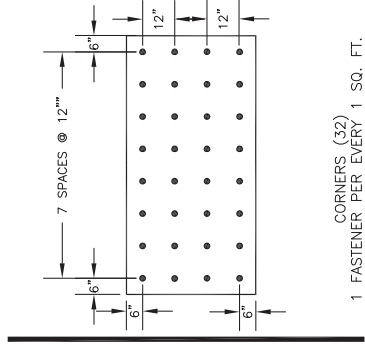
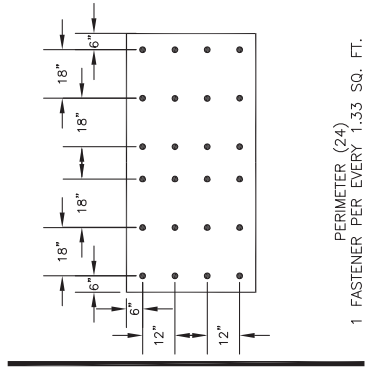
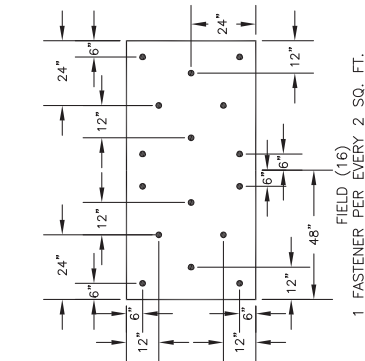

**MULE-HIDE  
PRODUCTS CO., INC.**

**INSULATION ATTACHMENT  
16 FASTENERS PER 4' X 8' IN FIELD  
SYSTEMS:  
FULLY ADHERED**

**DETAIL NO.:**  
**MHT-FA-722**  
REVISION DATE: 10/2013

NOTES:

1. 17 FASTENERS PER 4' X 8' BOARD IN THE FIELD IS APPROVED FOR OSB COVER BOARDS OR OSB/POLYISOCYANURATE COMPOSITE INSULATION.
2. PERIMETER AND CORNER DIMENSIONS ARE TO BE A MINIMUM OF 8' WIDE UNLESS THE PROJECT REQUIRES FACTORY MUTUAL COMPLIANCE. CONTACT MULE-HIDE TECHNICAL DEPARTMENT FOR FACTORY MUTUAL REQUIREMENTS.
3. MULE-HIDE FASTENERS AND 3" STRESS PLATES MUST BE USED FOR INSULATION ATTACHMENT.
4. REFER TO MULE-HIDE WIND UPLIFT RATINGS FOR APPROPRIATE FASTENER DENSITY REQUIRED.
5. FASTENER DENSITY INCREASES BASED ON THE FOLLOWING:
  - 50% FOR PERIMETERS
  - 100% FOR CORNERS

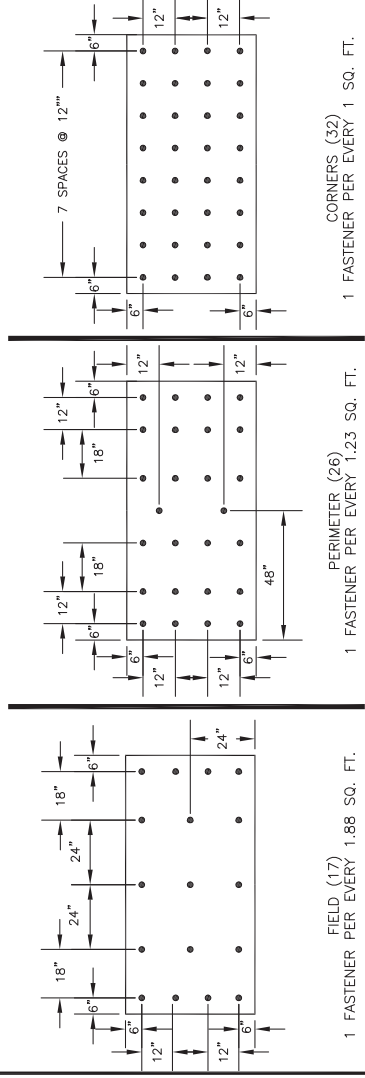

**MULE-HIDE  
PRODUCTS CO., INC.**

**INSULATION ATTACHMENT  
SYSTEMS:  
FULLY ADHERED**

**DETAIL NO.:  
MHT-FA-723**  
REVISION DATE: 10/2013

NOTES:

1. THESE FASTENING PATTERNS ARE TO BE USED WHEN THE PROJECT REQUIRES A FACTORY MUTUAL RATED SYSTEM. CONTACT MULE-HIDE TECHNICAL DEPARTMENT FOR APPROPRIATE USE OF THESE PATTERNS.
2. MULE-HIDE INSULATION FASTENERS AND 3" DIAMETER PLATES MUST BE USED FOR INSULATION ATTACHMENT.
3. REFER TO MULE-HIDE WIND UPLIFT RATINGS FOR APPROPRIATE FASTENER DENSITY REQUIRED.
4. FASTENER DENSITY INCREASES BASED ON THE FOLLOWING:
  - 50% FOR PERIMETERS WITH A MINIMUM OF 1 FASTENER EVERY 2 SQUARE FEET NOT TO EXCEED 1 FASTENER EVERY 1 SQUARE FOOT
  - CONSTANT DENSITY OF 1 FASTENER EVERY 1 SQUARE FOOT FOR CORNERS.

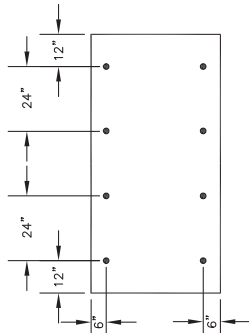

FIELD (8)  
1 FASTENER PER EVERY 4 SQ. FT.

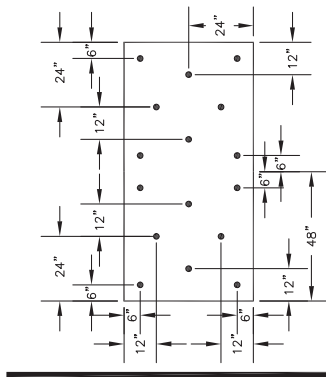

PERIMETER (16)  
1 FASTENER PER EVERY 2 SQ. FT.

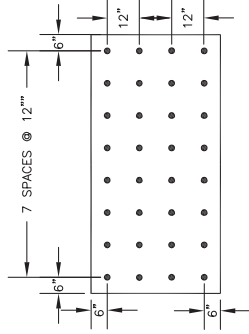

CORNERS (32)  
1 FASTENER PER EVERY 1 SQ. FT.

**MULE-HIDE  
PRODUCTS CO., INC.**

**FM - 8 FIELD FASTENERS  
PER 4' X 8' BOARD PATTERN LAYOUT**

**SYSTEMS:**

**FULLY ADHERED**

**DETAIL NO.:**

**MHT-FM-724**

REVISION DATE: 06/2015



NOTES:

1. THESE FASTENING PATTERNS ARE TO BE USED WHEN THE PROJECT REQUIRES A FACTORY MUTUAL RATED SYSTEM. CONTACT MULE-HIDE TECHNICAL DEPARTMENT FOR APPROPRIATE USE OF THESE PATTERNS.
2. MULE-HIDE INSULATION FASTENERS AND 3" DIAMETER PLATES MUST BE USED FOR INSULATION ATTACHMENT.
3. REFER TO MULE-HIDE WIND UPLIFT RATINGS FOR APPROPRIATE FASTENER DENSITY REQUIRED.
4. FASTENER DENSITY INCREASES BASED ON THE FOLLOWING:
  - 50% FOR PERIMETERS WITH A MINIMUM OF 1 FASTENER EVERY 2 SQUARE FEET NOT TO EXCEED 1 FASTENER EVERY 1 SQUARE FOOT
  - CONSTANT DENSITY OF 1 FASTENER EVERY 1 SQUARE FOOT FOR CORNERS.

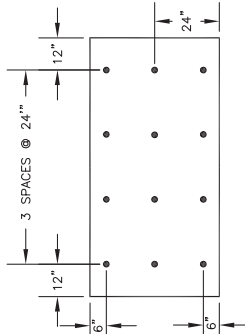

FIELD (12)  
1 FASTENER PER EVERY 2.66 SQ. FT.

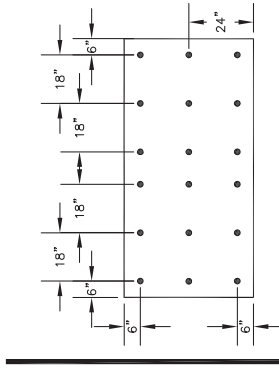

PERIMETER (18)  
1 FASTENER PER EVERY 1.77 SQ. FT.

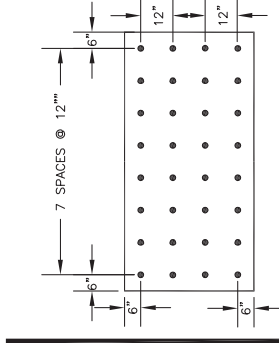

CORNERS (32)  
1 FASTENER PER EVERY 1 SQ. FT.

**FM - 12 FIELD FASTENERS  
PER 4' X 8' BOARD PATTERN LAYOUT  
SYSTEMS:**

**FULLY ADHERED**

**DETAIL NO.:**

**MHT-FM-725**

REVISION DATE: 06/2015

**MULE-HIDE  
PRODUCTS CO., INC.**

NOTES:

1. THESE FASTENING PATTERNS ARE TO BE USED WHEN THE PROJECT REQUIRES A FACTORY MUTUAL RATED SYSTEM. CONTACT MULE-HIDE TECHNICAL DEPARTMENT FOR APPROPRIATE USE OF THESE PATTERNS.
2. MULE-HIDE INSULATION FASTENERS AND 3" DIAMETER PLATES MUST BE USED FOR INSULATION ATTACHMENT.
3. REFER TO MULE-HIDE WIND UPLIFT RATINGS FOR APPROPRIATE FASTENER DENSITY REQUIRED.
4. FASTENER DENSITY INCREASES BASED ON THE FOLLOWING:
  - 50% FOR PERIMETERS WITH A MINIMUM OF 1 FASTENER EVERY 2 SQUARE FEET NOT TO EXCEED 1 FASTENER EVERY 1 SQUARE FOOT
  - CONSTANT DENSITY OF 1 FASTENER EVERY 1 SQUARE FOOT FOR CORNERS.

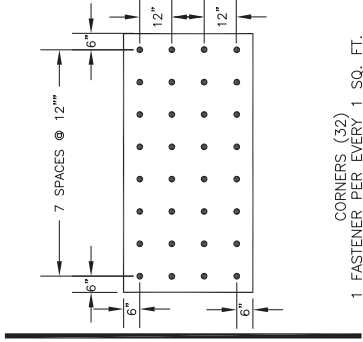
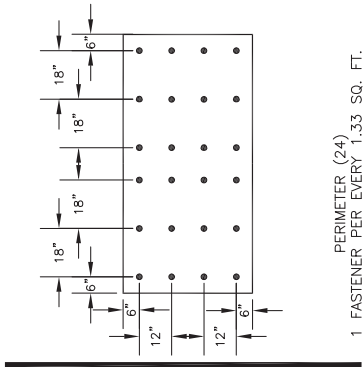
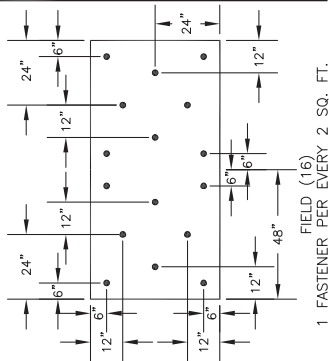

**MULE-HIDE  
PRODUCTS CO., INC.**

**FM - 16 FIELD FASTENERS  
PER 4' X 8' BOARD PATTERN LAYOUT  
SYSTEMS:**

**FULLY ADHERED**

**DETAIL NO.:**

**MHT-FM-726**

REVISION DATE: 10/2013

NOTES:

1. THESE FASTENING PATTERNS ARE TO BE USED WHEN THE PROJECT REQUIRES A FACTORY MUTUAL RATED SYSTEM. CONTACT MULE-HIDE TECHNICAL DEPARTMENT FOR APPROPRIATE USE OF THESE PATTERNS.
2. MULE-HIDE INSULATION FASTENERS AND 3" DIAMETER PLATES MUST BE USED FOR INSULATION ATTACHMENT.
3. REFER TO MULE-HIDE WIND UPLIFT RATINGS FOR APPROPRIATE FASTENER DENSITY REQUIRED.
4. FASTENER DENSITY INCREASES BASED ON THE FOLLOWING:
  - 50% FOR PERIMETERS WITH A MINIMUM OF 1 FASTENER EVERY 2 SQUARE FEET NOT TO EXCEED 1 FASTENER EVERY 1 SQUARE FOOT
  - CONSTANT DENSITY OF 1 FASTENER EVERY 1 SQUARE FOOT FOR CORNERS.

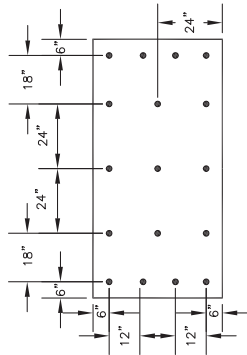

FIELD (17)  
1 FASTENER PER EVERY 1.88 SQ. FT.

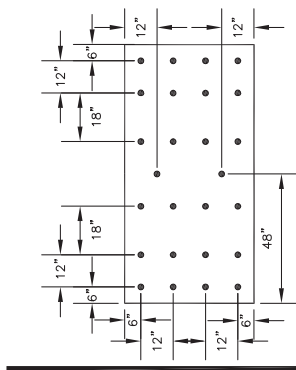

PERIMETER (26)  
1 FASTENER PER EVERY 1.23 SQ. FT.

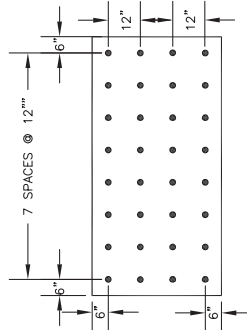

CORNERS (32)  
1 FASTENER PER EVERY 1 SQ. FT.

**MULE-HIDE  
PRODUCTS CO., INC.**

**FM - 17 FIELD FASTENERS  
PER 4' X 8' BOARD PATTERN LAYOUT  
SYSTEMS:**

**FULLY ADHERED**

**DETAIL NO.:**  
**MHT-FM-727**

REVISION DATE: 10/2013

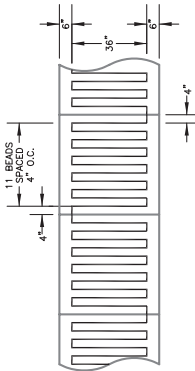

FIGURE 1  
INSTALLATION USING 4" O.C.  
BEADS ON 4" X 4" BOARDS

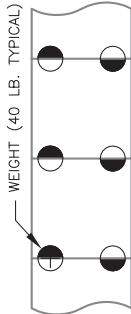

FIGURE 2  
RECOMMENDED WEIGHT  
PLACEMENT ON 4' X 4' BOARDS

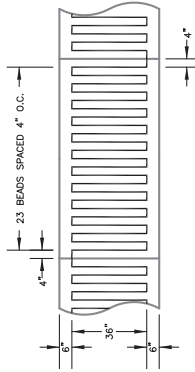

FIGURE 3  
INSTALLATION USING 4" O.C.  
BEADS ON 4' X 8' BOARDS

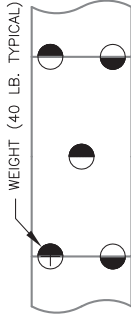

FIGURE 4  
RECOMMENDED WEIGHT  
PLACEMENT ON 4' X 8' BOARDS

INSULATION TYPE	MAXIMUM BOARD SIZE
HIGH DENSITY WOOD FIBERBOARD	4' X 4'
POLYISOCYANURATE	4' X 4'
EXTRUDED POLYSTYRENE (XPS)	2' X 8'
EXPANDED POLYSTYRENE (EPS)	4' X 4'
DENS. DECK PRIME	4' X 8'
SECURROCK	4' X 8'
ORIENTED STRAND BOARD (OSB)	4' X 8'

COVERAGE RATES	CARTRIDGES*	TANKS
3/4" BEADS 12" O.C.	600 S.F.	3,000 S.F.
3/4" BEADS 6" O.C.	300 S.F.	1,500 S.F.
3/4" BEADS 4" O.C.	200 S.F.	1,000 S.F.

\* COVERAGE RATES FOR CARTRIDGES ARE BASED ON CARTON QUANTITIES, 4 CARTRIDGES PER CARTON

HELIX FOAM ADHESIVE  
4" RIBBON PATTERN  
SYSTEMS:  
ALL SYSTEMS

DETAIL NO.:  
**MHHA-UN-4**  
REVISION DATE: 03/2017

**MULE-HIDE  
PRODUCTS CO., INC.**

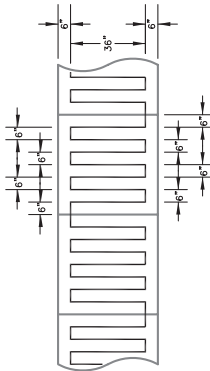

FIGURE 1  
INSTALLATION USING 6" O.C.  
BEADS ON 4' X 4' BOARDS

WEIGHT (40 LB. TYPICAL)

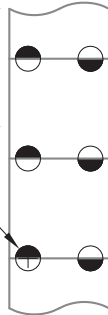

FIGURE 2  
RECOMMENDED WEIGHT  
PLACEMENT ON 4' X 4' BOARDS

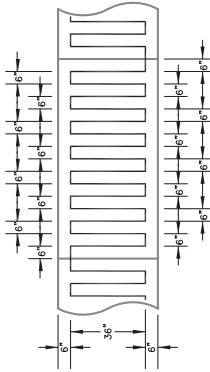

FIGURE 3  
INSTALLATION USING 6" O.C.  
BEADS ON 4' X 8' BOARDS

WEIGHT (40 LB. TYPICAL)

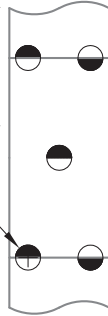

FIGURE 4  
RECOMMENDED WEIGHT  
PLACEMENT ON 4' X 8' BOARDS

INSULATION TYPE	MAXIMUM BOARD SIZE
HIGH DENSITY WOOD FIBERBOARD	4' X 4'
POLYISOCYANURATE	4' X 4'
EXTRUDED POLYSTYRENE (XPS)	2' X 8'
EXPANDED POLYSTYRENE (EPS)	4' X 4'
DENS. DECK PRIME	4' X 8'
SEUROCK	4' X 8'
ORIENTED STRAND BOARD (OSB)	4' X 8'

COVERAGE RATES	CARTRIDGES*	TANKS
3/4" BEADS 12" O.C.	600 S.F.	3,000 S.F.
3/4" BEADS 6" O.C.	300 S.F.	1,500 S.F.
3/4" BEADS 4" O.C.	200 S.F.	1,000 S.F.

\* COVERAGE RATES FOR CARTRIDGES ARE BASED ON CARTON QUANTITIES, 4 CARTRIDGES PER CARTON

HELIX FOAM ADHESIVE  
6" RIBBON PATTERN  
SYSTEMS:

ALL SYSTEMS

DETAIL NO.:

**MHHA-UN-6**

REVISION DATE: 03/2017

**MULE-HIDE  
PRODUCTS CO., INC.**

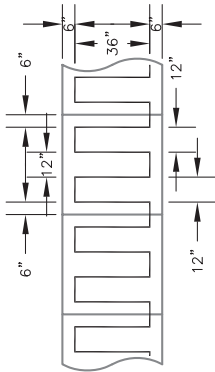

FIGURE 1  
INSTALLATION USING 12" O.C.  
BEADS ON 4' X 4' BOARDS

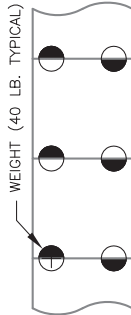

FIGURE 2  
RECOMMENDED WEIGHT  
PLACEMENT ON 4' X 4' BOARDS

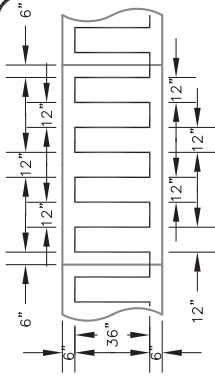

FIGURE 3  
INSTALLATION USING 12" O.C.  
BEADS ON 4' X 8' BOARDS

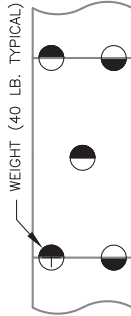

FIGURE 4  
RECOMMENDED WEIGHT  
PLACEMENT ON 4' X 8' BOARDS

INSULATION TYPE	MAXIMUM BOARD SIZE
HIGH DENSITY WOOD FIBERBOARD	4' X 4'
POLYISOCYANURATE	4' X 4'
EXTRUDED POLYSTYRENE (XPS)	2' X 8'
EXPANDED POLYSTYRENE (EPS)	4' X 4'
DENS DECK PRIME	4' X 8'
SECUROCK	4' X 8'
ORIENTED STRAND BOARD (OSB)	4' X 8'

COVERAGE RATES	CARTRIDGES*	TANKS
3/4" BEADS 12" O.C.	600 S.F.	3,000 S.F.
3/4" BEADS 6" O.C.	300 S.F.	1,500 S.F.
3/4" BEADS 4" O.C.	200 S.F.	1,000 S.F.

\* COVERAGE RATES FOR CARTRIDGES ARE BASED ON CARTON QUANTITIES, 4 CARTRIDGES PER CARTON

**MULE-HIDE  
PRODUCTS CO., INC.**

**HELIX FOAM ADHESIVE  
12" RIBBON PATTERN  
SYSTEMS:  
ALL SYSTEMS**

**DETAIL NO.:**  
**MHHA-UN-12**  
**REVISION DATE:** 03/2017

1

1. INSTALL CONTINUOUS CLEAT.  
2. INSTALL MEMBRANE COATED METAL WITH 1/2" JOINTS BETWEEN ADJOINING SECTIONS.

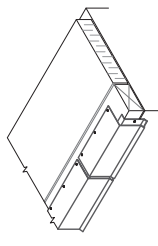

2

INSTALL 2" WIDE DUCT TAPE OVER JOINTS OF MEMBRANE COATED METAL & COMPLETELY COVER THE JOINT.

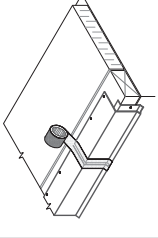

3

HEAT WELD 6" WIDE PIECE OF MULE-HIDE NON-REINFORCED MEMBRANE OVER THE JOINT.

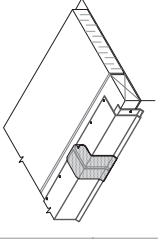

4

POSITION MULE-HIDE REINFORCED FIELD MEMBRANE AND HEAT WELD TO MEMBRANE COATED METAL, A MINIMUM OF 1 1/2" AS SHOWN.

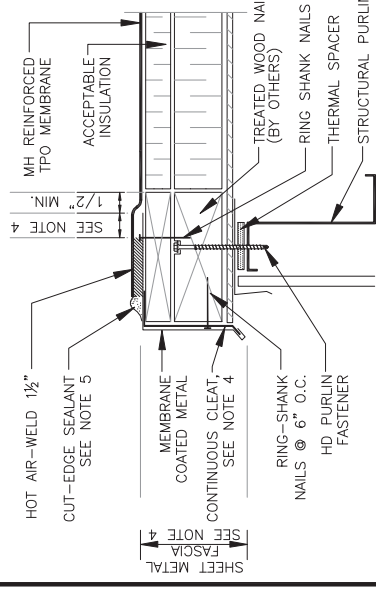
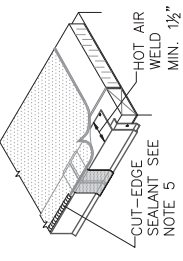

NOTES:

1. REFER TO METAL RETROFIT SPECS FOR PROPER WOOD NAILER FASTENING CRITERIA.
2. INSPECT THE STRUCTURAL INTEGRITY OF EXISTING STEEL MEMBER(S) PRIOR TO ANCHORING NEW WOOD BLOCKING.
3. THICKNESS OF WOOD NAILER(S) TO MATCH WITH THE THICKNESS OF INSULATION.
4. SEE DETAIL T3.1 FOR METAL EDGE INSTALLATION AND REQUIREMENTS OF ANSI/SPRI ES-1 COMPLIANCE.
5. APPROXIMATELY 1/8" DIAMETER BEAD OF CUT-EDGE SEALANT IS REQUIRED ON CUT EDGES OF REINFORCED MEMBRANE.

NOTE:

NOT APPROVED FOR 20-YEAR SYSTEM WARRANTIES OR FOR USE IN HIGH WIND AREAS

**MULE-HIDE PRODUCTS CO., INC.**  
2011

PERIMETER EDGE METAL MEMBRANE COATED METAL SYSTEMS:  
METAL RETROFIT SYSTEMS  
TPO MECHANICALLY ATTACHED

DETAIL NO.:  
**MMRT-101**

**NOTES:**

1. REFER TO METAL RETROFIT SPECS FOR PROPER WOOD NAILER FASTENING CRITERIA.
2. INSPECT THE STRUCTURAL INTEGRITY OF EXISTING STEEL MEMBER(S) PRIOR TO ANCHORING NEW WOOD BLOCKING.
3. THICKNESS OF WOOD NAILER(S) TO MATCH THE THICKNESS OF NEW INSULATION.
4. FASTENERS USED TO ATTACH SHEET METAL MUST PENETRATE WOOD NAILER A MINIMUM OF 1/4". IF PLYWOOD IS USED AS THE TOP LAYER, FASTENERS MUST PENETRATE A MINIMUM OF 1/4" INTO WOOD NAILER BELOW.
5. TO REMOVE FINISHING OILS, AT NON-COATED METALS, SCRUB METAL FLANGE WITH WEATHERED MEMBRANE CLEANER AND ALLOW TO DRY PRIOR TO THE PRIMER.
6. APPLY TAPE PRIMER TO METAL FLANGE AND TPO MEMBRANE SURFACE PRIOR TO INSTALLING PRESSURE-SENSITIVE CURED COVER STRIP.
7. REFER TO METAL RETROFIT SPEC FOR PROPER MEMBRANE SPLICING PROCEDURES.

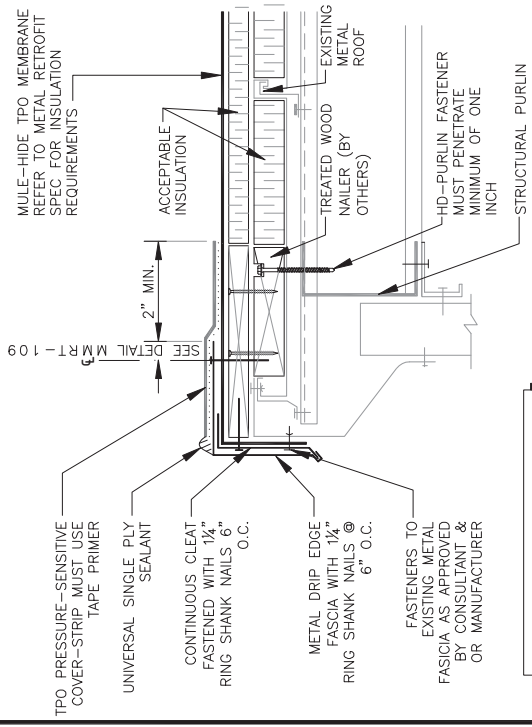

**NOTE:**  
THIS DETAIL APPROVED FOR 20-YEAR SYSTEM WARRANTIES.

<p><b>MULE-HIDE PRODUCTS CO., INC.</b> 2011</p>	<p>WITH PRESSURE SENSITIVE COVER STRIP SYSTEMS: METAL RETROFIT TPO MECHANICALLY ATTACHED</p>	<p>DETAIL NO.: <b>MMRT-102</b></p>
	<p>RAKE DRIP EDGE WITH PRESSURE SENSITIVE COVER STRIP</p>	



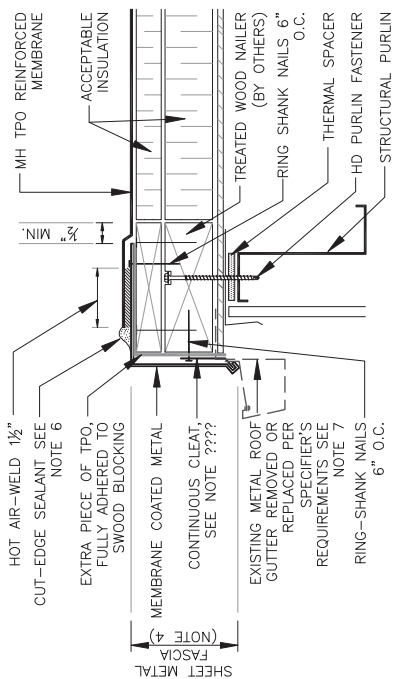

NOTE:  
 NOT APPROVED FOR 20-YEAR  
 SYSTEM WARRANTIES OR FOR  
 USE IN HIGH WIND AREAS

- NOTES:
1. REFER TO METAL RETROFIT SPECS FOR PROPER WOOD NAILER FASTENING CRITERIA.
  2. INSPECT THE STRUCTURAL INTEGRITY OF EXISTING STEEL MEMBER(S) PRIOR TO ANCHORING NEW WOOD BLOCKING.
  3. THICKNESS OF WOOD NAILER(S) TO MATCH THICKNESS OF NEW INSULATION.
  4. SEE MMRT-109 FOR METAL EDGE INSTALLATION AND REQUIREMENTS OF ANSI/SPRI ES-1 COMPLIANCE.
  5. FASTENERS USED TO ATTACH SHEET METAL MUST PENETRATE WOOD NAILER A MINIMUM OF 1/4". IF PLYWOOD IS USED AS THE TOP LAYER, FASTENERS MUST PENETRATE A MINIMUM OF 1/4" INTO WOOD NAILER BELOW.
  6. APPROXIMATELY 1/8" DIAMETER BEAD OF CUT-EDGE SEALANT IS REQUIRED ON CUT EDGES OF REINFORCED TPO MEMBRANE.
  7. GUTTER FASTENERS & FASTENERS' PATTERN AS RECOMMENDED BY GUTTER MANUFACTURER.

<b>MULE-HIDE          PRODUCTS CO., INC.          2011</b>	<b>MEMBRANE COATED DRIP EDGE          WITH GUTTER          SYSTEMS:          METAL RETROFIT          TPO MECHANICALLY ATTACHED</b>	<b>DETAIL NO.:</b> <b>MMRT-103</b>

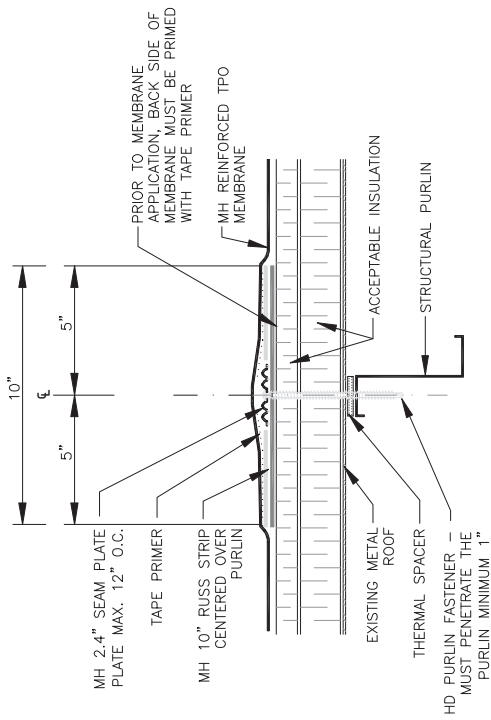

NOTES:

1. REFER TO METAL RETROFIT SPEC FOR PROPER MEMBRANE SPlicing PROCEDURES.

**MULE-HIDE PRODUCTS CO., INC.**  
2011

**10" RUSS STRIP MEMBRANE SECUREMENT SYSTEMS: METAL RETROFIT TPO MECHANICALLY ATTACHED**

DETAIL NO.: **MMRT-110**

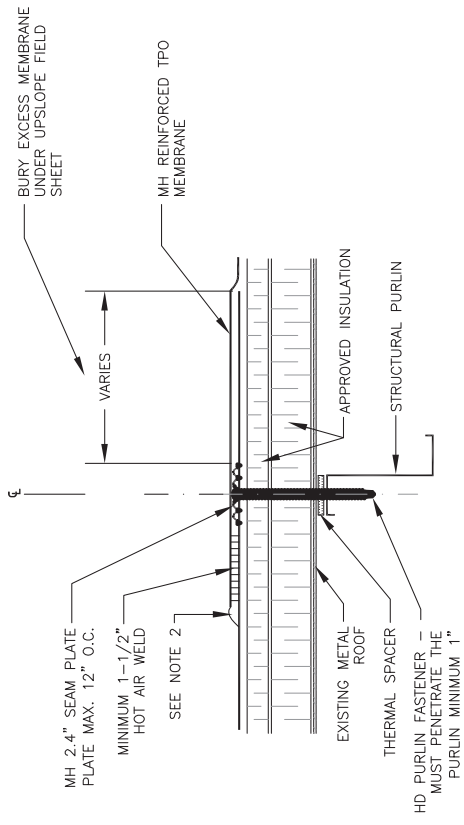

- NOTES:
1. REFER TO METAL RETROFIT SPEC FOR PROPER MEMBRANE SPlicing PROCEDURES.
  2. APPROXIMATELY 3/8" DIAMETER BEAD OF CUT-EDGE SEALANT IS REQUIRED ON CUT EDGES OF TPO REINFORCED MEMBRANE.

<b>MULE-HIDE PRODUCTS CO., INC. 2012</b>	<b>SEAM FASTENING NARROW ROLLS MEMBRANE SECUREMENT SYSTEMS: METAL RETROFIT TPO MECHANICALLY ATTACHED</b>	<b>DETAIL NO.:</b> <b>MMRT-111</b>
--	--	---------------------------------------

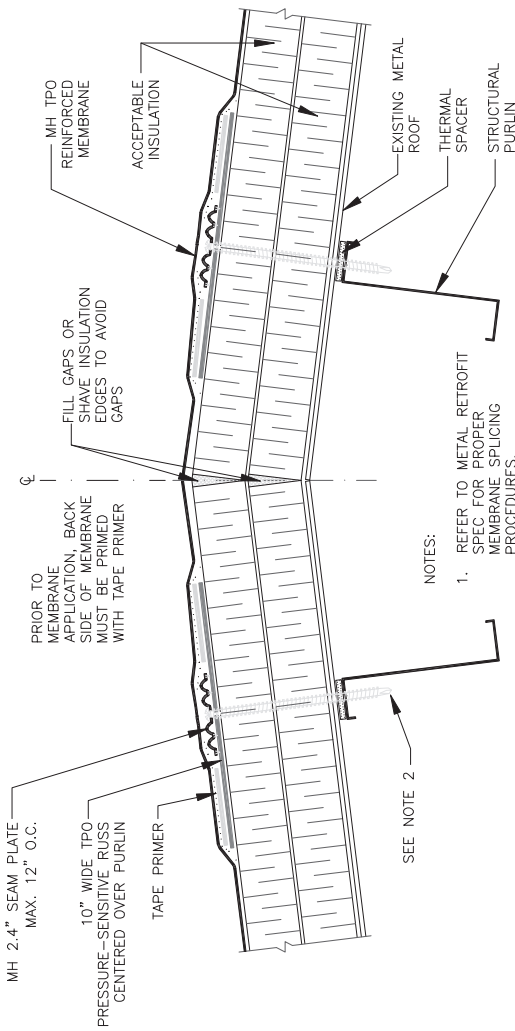

PRIOR TO  
MEMBRANE  
APPLICATION, BACK  
SIDE OF MEMBRANE  
MUST BE PRIMED  
WITH TAPE PRIMER

MH 2.4" SEAM PLATE  
MAX. 12" O.C.

10" WIDE TPO  
PRESSURE-SENSITIVE RUSS  
CENTERED OVER PURLIN

TAPE PRIMER

FILL GAPS OR  
SHAVE INSULATION  
EDGES TO AVOID  
GAPS

MH TPO  
REINFORCED  
MEMBRANE

ACCEPTABLE  
INSULATION

EXISTING METAL  
ROOF

THERMAL  
SPACER

STRUCTURAL  
PURLIN

NOTES:

1. REFER TO METAL RETROFIT SPEC FOR PROPER MEMBRANE SPlicing PROCEDURES.
2. HD PURLIN FASTENERS MUST PENETRATE THE PURLIN A MINIMUM OF 1".
3. MEMBRANE SHALL BE FASTENED INTO PURLINS ADJACENT TO THE ROOF RIDGE.

SEE NOTE 2

**MULE-HIDE  
PRODUCTS CO., INC.  
2011**

**10" RUSS  
RIDGE SECUREMENT DETAIL  
SYSTEMS:  
METAL RETROFIT  
TPO MECHANICALLY ATTACHED**

**DETAIL NO. :  
MMRT-180**

## 12' WIDE TPO MEMBRANE

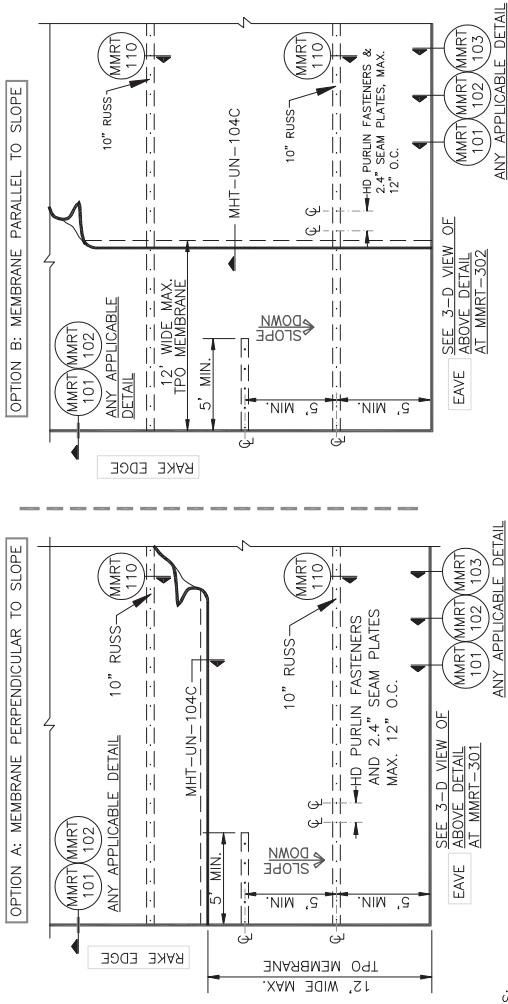

**NOTES:**

1. WHEN MEMBRANE SHEETS ARE POSITIONED PERPENDICULAR TO THE ROOF SLOPE (OPTION A), ALL FIELD SPLICES MUST BE SHINGLED. MEMBRANE SHEETS MAY ALSO BE POSITIONED PARALLEL TO THE ROOF SLOPE, WHEN ATTACHED TO THE RUSS AS SHOWN IN OPTION B ABOVE.
2. RUSS/MEMBRANE MUST BE SECURED TO THE STRUCTURAL PURLINS WITH HD PURLIN FASTENERS AND 2.4" SEAM PLATES, SPACED A MAXIMUM OF 12 INCHES ON CENTER.

<b>MULE-HIDE PRODUCTS CO., INC. 2011</b>	<b>100 MPH OR LESS WIND ZONES MECHANICALLY ATTACHED SYSTEM</b>  <b>SYSTEMS: METAL RETROFIT TPO MECHANICALLY ATTACHED</b>
<b>DETAIL NO.: MMRT-300</b>	

NOTES:

1. RUSS/MEMBRANE MUST BE SECURED TO THE STRUCTURAL PURLINS - MINIMUM ONE INCH PENETRATION PAST THE THICKNESS OF STRUCTURAL PURLINS. REFER TO SEAM CUT & RUSS CUT DETAILS FOR ADDITIONAL INFORMATION.
2. MEMBRANE SEAMS (SIDE LAPS AND END LAPS) SHALL BE IN SHINGLED FASHION. REFER TO TABLE BELOW FOR MEMBRANE POSITIONING & DIRECTIONS AND APPLICABLE CROSS REFERENCES.

TPO, PRESSURE-SENSITIVE RUSS WITH HD PURLIN FASTENERS & 2.4" SEAM PLATES MAX. 12" O.C. (TYP.) SEE DETAIL MMRT-110

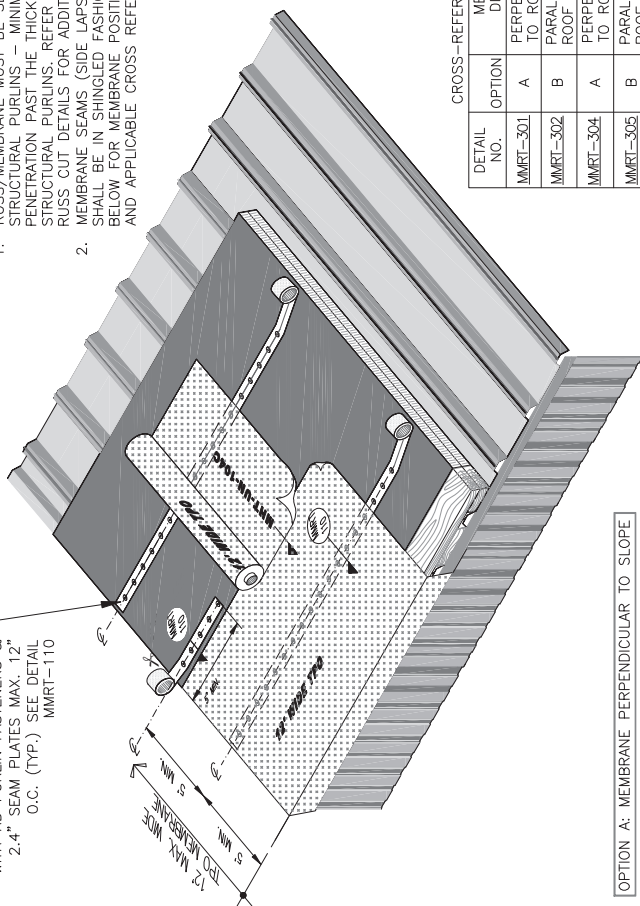

OPTION A: MEMBRANE PERPENDICULAR TO SLOPE

CROSS-REFERENCE TABLE

DETAIL NO.	OPTION	MEMBRANE DIRECTION ZONE	WIND ZONE
MMRT-301	A	PERPENDICULAR TO ROOF SLOPE	100 MPH OR LESS
MMRT-302	B	PARALLEL TO ROOF SLOPE	100 MPH OR LESS
MMRT-304	A	PERPENDICULAR TO ROOF SLOPE	101-120 MPH
MMRT-305	B	PARALLEL TO ROOF SLOPE	101-120 MPH

100 MPH OR LESS WIND ZONES MECHANICALLY ATTACHED

SYSTEMS:  
METAL RETROFIT TPO MECHANICALLY ATTACHED

**MULE-HIDE PRODUCTS CO., INC.**  
2011

DETAIL NO.:  
**MMRT-301**

TPO PRESSURE-SENSITIVE RUSS WITH HD PURLIN FASTENERS & 2.4" SEAM PLATES MAX. 12" O.C. (TYP.). SEE DETAIL MMRT-110

- RUSS/MEMBRANE MUST BE SECURED TO THE STRUCTURAL PURLINS — MINIMUM ONE INCH PENETRATION PAST THE THICKNESS OF STRUCTURAL PURLINS. REFER TO SEAM CUT & RUSS CUT DETAILS FOR ADDITIONAL INFORMATION.
- MEMBRANE SEAMS (SIDE LAPS AND END LAPS) SHALL BE IN SHINGLED FASHION. REFER TO TABLE BELOW FOR MEMBRANE POSITIONING & DIRECTIONS AND APPLICABLE CROSS REFERENCES.

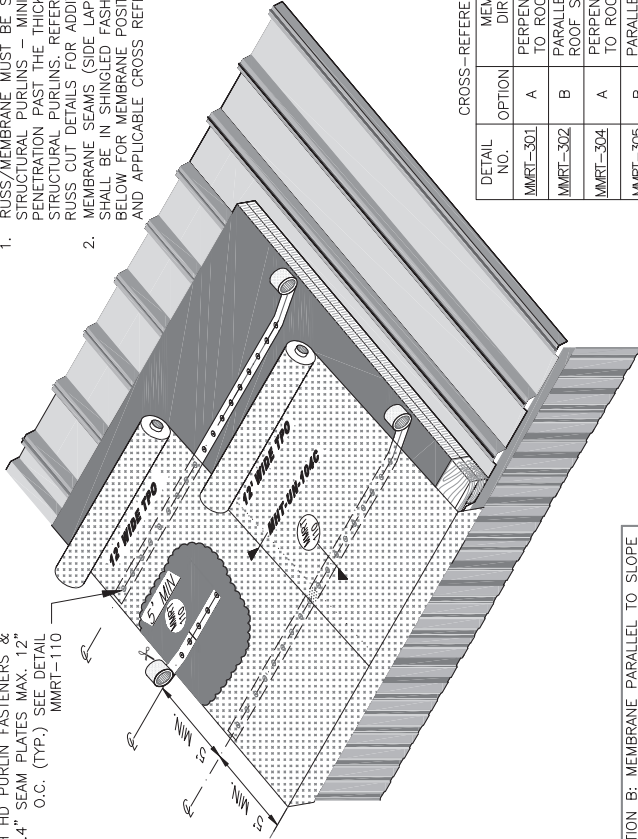

OPTION B: MEMBRANE PARALLEL TO SLOPE

CROSS-REFERENCE TABLE

DETAIL NO.	OPTION	MEMBRANE DIRECTION	WIND ZONE
MMRT-301	A	PERPENDICULAR TO ROOF SLOPE	100 MPH OR LESS
MMRT-302	B	PARALLEL TO ROOF SLOPE	100 MPH OR LESS
MMRT-304	A	PERPENDICULAR TO ROOF SLOPE	101-120 MPH
MMRT-305	B	PARALLEL TO ROOF SLOPE	101-120 MPH

**MULE-HIDE PRODUCTS CO., INC.**  
2011

101-120 MPH WIND ZONES MECHANICALLY ATTACHED SYSTEMS:  
METAL RETROFIT TPO MECHANICALLY ATTACHED

DETAIL NO.:  
**MMRT-302**

12' WIDE TPO MEMBRANE

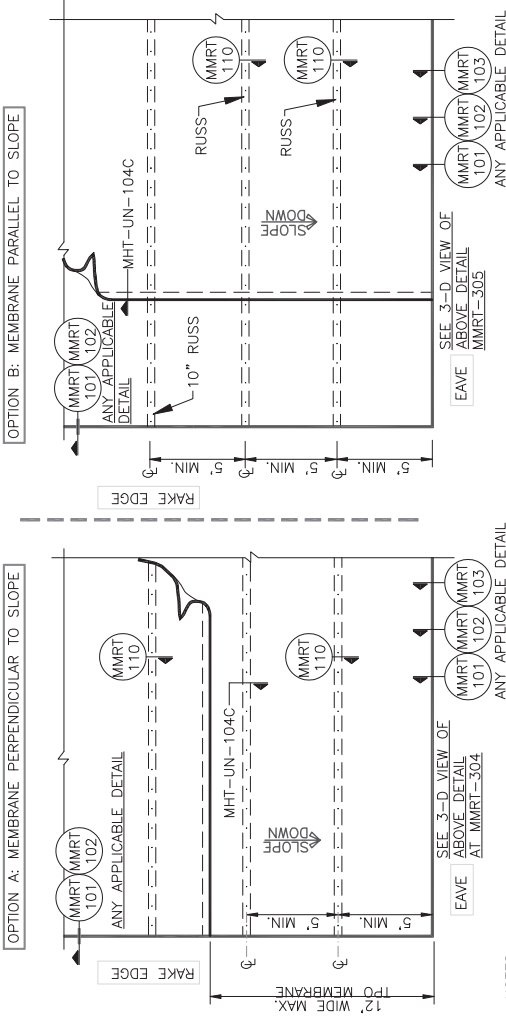

NOTES:

1. WHEN MEMBRANE SHEETS ARE POSITIONED PERPENDICULAR TO THE ROOF SLOPE (OPTION A), ALL FIELD SPLICES MUST BE SHINGLED. MEMBRANE SHEETS MAY ALSO BE POSITIONED PARALLEL TO THE ROOF SLOPE, WHEN ATTACHED TO THE RUSS AS SHOWN IN OPTION B ABOVE.
2. RUSS/MEMBRANE MUST BE SECURED TO THE STRUCTURAL PURLINS WITH HD PURLIN FASTENERS AND 2.4" SEAM PLATES, SPACED A MAXIMUM OF 12 INCHES ON CENTER.

**MULE-HIDE  
PRODUCTS CO., INC.  
2011**

**101-120 MPH WIND ZONES  
MECHANICALLY ATTACHED**

**SYSTEMS:  
METAL RETROFIT  
TPO MECHANICALLY ATTACHED**

**DETAIL NO.:**  
**MMRT-303**



NOTES:

1. RUSS/MEMBRANE MUST BE SECURED TO THE STRUCTURAL PURLINS - MINIMUM ONE INCH PENETRATION PAST THE THICKNESS OF STRUCTURAL PURLINS. REFER TO SEAM CUT & RUSS CUT DETAILS FOR ADDITIONAL INFORMATION.
2. MEMBRANE SEAMS (SIDE LAPS AND END LAPS) SHALL BE IN SHINGLED FASHION. REFER TO TABLE BELOW FOR MEMBRANE POSITIONING & DIRECTIONS AND APPLICABLE CROSS REFERENCES.

TPO PRESSURE-SENSITIVE RUSS WITH HD PURLIN FASTENERS & 2.4" SEAM PLATES MAX. 12" O.C. (TYP.) SEE DETAIL MMRT-110

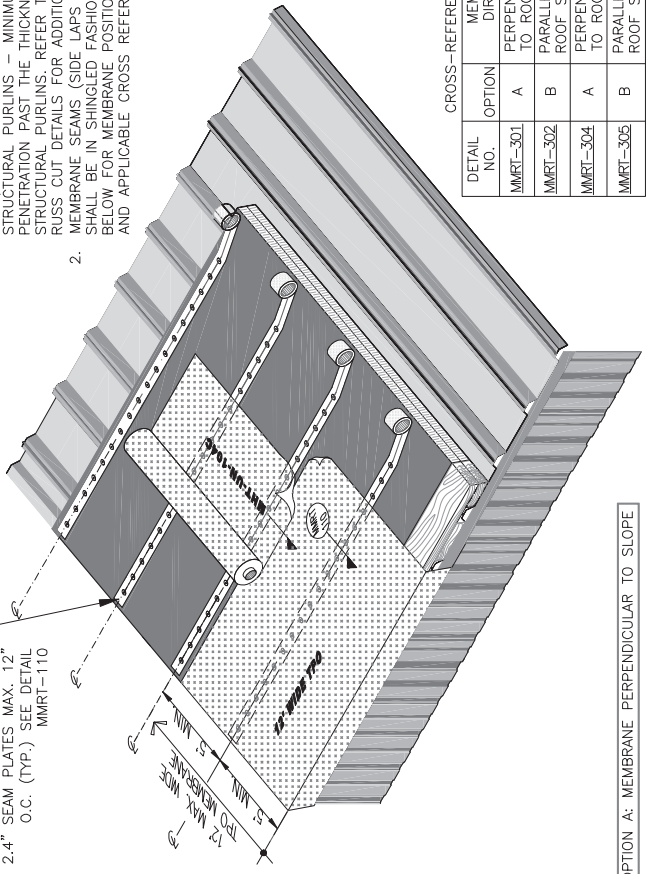

OPTION A: MEMBRANE PERPENDICULAR TO SLOPE

CROSS-REFERENCE TABLE

DETAIL NO.	OPTION	MEMBRANE DIRECTION	WIND ZONE
MMRT-301	A	PERPENDICULAR TO ROOF SLOPE	100 MPH OR LESS
MMRT-302	B	PARALLEL TO ROOF SLOPE	100 MPH OR LESS
MMRT-304	A	PERPENDICULAR TO ROOF SLOPE	101-120 MPH
MMRT-305	B	PARALLEL TO ROOF SLOPE	101-120 MPH

**MULE-HIDE PRODUCTS CO., INC.**  
2011

101-120 MPH WIND ZONES  
MECHANICALLY ATTACHED SYSTEMS:  
METAL RETROFIT  
TPO MECHANICALLY FASTENED

DETAIL NO.:  
**MMRT-304**

TPO PRESSURE-SENSITIVE RUSS WITH HD PURLIN FASTENERS & 2.4" SEAM PLATES MAX. 12" O.C. (TYP.) SEE DETAIL MMRT-110

- NOTES:
1. RUSS/MEMBRANE MUST BE SECURED TO THE STRUCTURAL PURLINS - MINIMUM ONE INCH PENETRATION PAST THE THICKNESS OF STRUCTURAL PURLINS. REFER TO SEAM CUT & MEMBRANE SEAMS (SIDE LAPS AND END LAPS) SHALL BE IN SHINGLED FASHION. REFER TO TABLE BELOW FOR MEMBRANE POSITIONING & DIRECTIONS AND APPLICABLE CROSS REFERENCES.
  2. RUSS CUT DETAILS FOR ADDITIONAL INFORMATION.

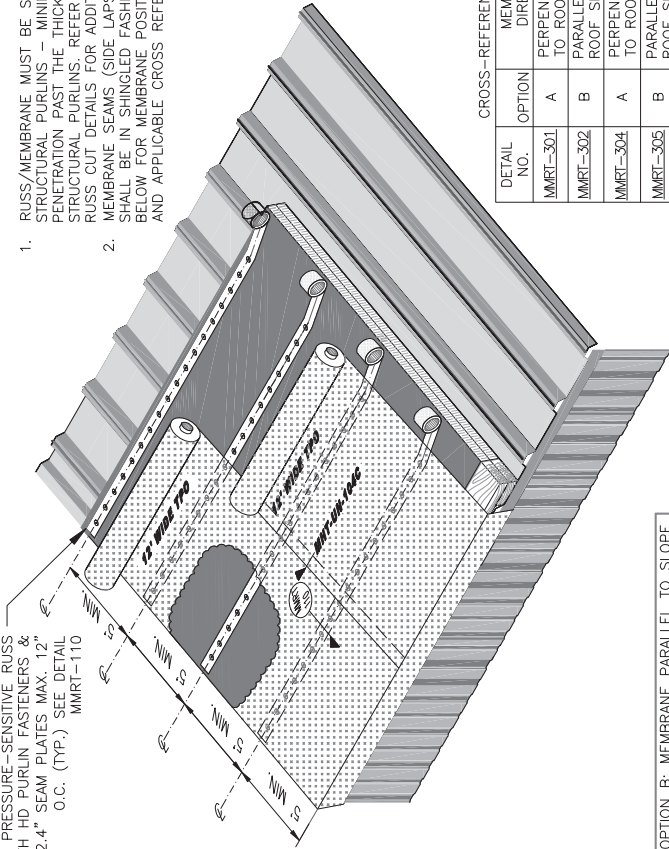

OPTION B: MEMBRANE PARALLEL TO SLOPE

CROSS-REFERENCE TABLE

DETAIL NO.	OPTION	MEMBRANE DIRECTION	WIND ZONE
MMRT-301	A	PERPENDICULAR TO ROOF SLOPE	100 MPH OR LESS
MMRT-302	B	PARALLEL TO ROOF SLOPE	100 MPH OR LESS
MMRT-304	A	PERPENDICULAR TO ROOF SLOPE	101-120 MPH
MMRT-305	B	PARALLEL TO ROOF SLOPE	101-120 MPH

**MULE-HIDE PRODUCTS CO., INC.**  
2011

101-120 MPH WIND ZONES  
MECHANICALLY ATTACHED  
SYSTEMS:  
METAL RETROFIT  
TPO MECHANICALLY ATTACHED

DETAIL NO.:  
**MMRT-305**

NARROW SHEETS FASTENED TO PURLINS WITH PURLIN FASTENERS 12" O.C. - EXCESS MEMBRANE IS BURIED UPSLOPE OF SEAM UNDER SUCCESSIVE FIELD SHEET

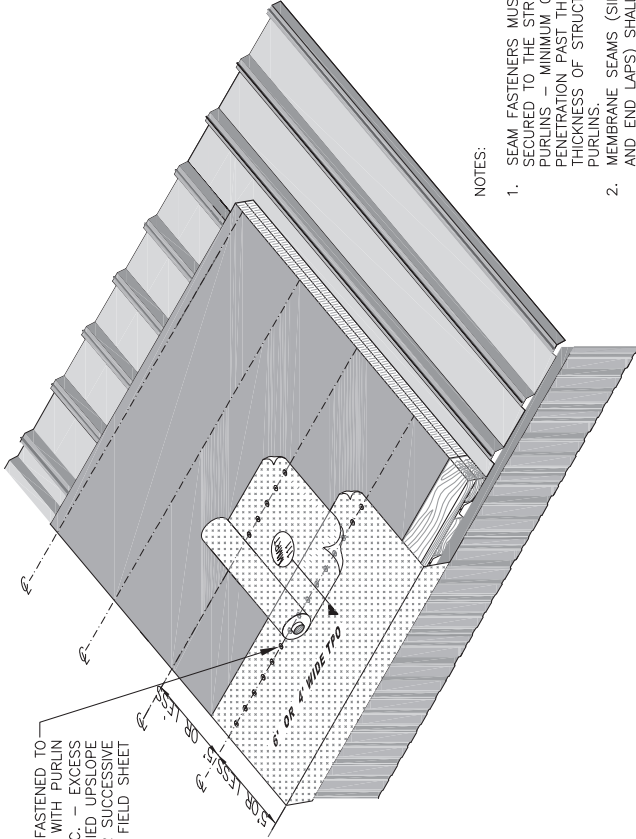

NOTES:

1. SEAM FASTENERS MUST BE SECURED TO THE STRUCTURAL PURLINS - MINIMUM ONE INCH PENETRATION PAST THE THICKNESS OF STRUCTURAL PURLINS.
2. MEMBRANE SEAMS (SIDE LAPS AND END LAPS) SHALL BE IN SHINGLED FASHION.

OPTION A: NARROW FIELD SHEETS (4' OR 6' WIDE)

**MULE-HIDE  
PRODUCTS CO., INC.  
2011**

101-120 MPH WIND ZONES  
NARROW SHEETS WITH SEAMS OVER PURLINS  
SYSTEMS:  
METAL RETROFIT  
TPO MECHANICALLY FASTENED

DETAIL NO.:  
**MMRT-310**

ADDITIONAL PERIMETER ATTACHMENT IS REQUIRED OVER INTERMEDIATE PURLIN — ATTACHMENT CAN BE DONE WITH 10" RUSS UNDER THE MEMBRANE OR FASTENERS AND PATCHED THROUGH THE TOP OF THE MEMBRANE

WIDE SHEETS FASTENED TO EVERY OTHER PURLIN WITH PURLIN FASTENERS 12" O.C. — EXCESS MEMBRANE IS BURIED UPSLOPE OF SEAM UNDER SUCCESSIVE FIELD SHEET

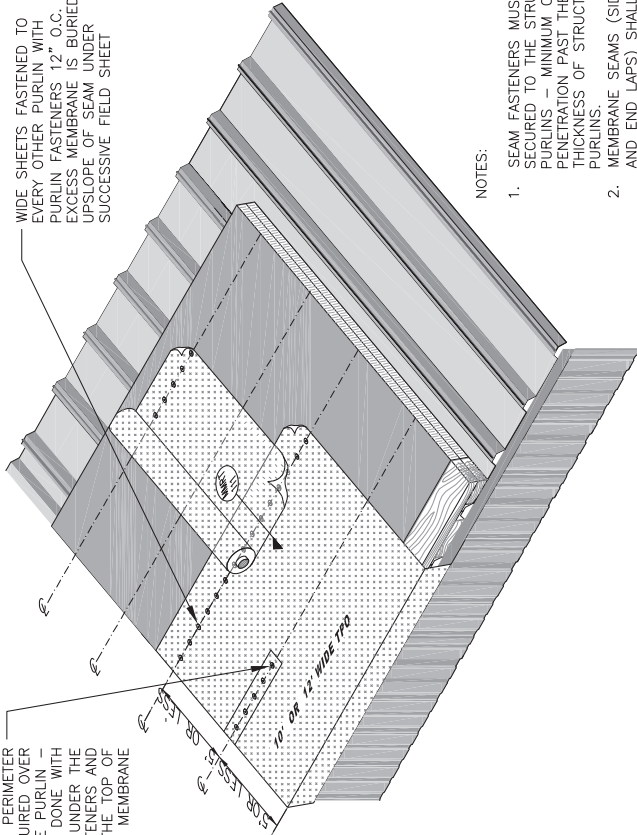

NOTES:

1. SEAM FASTENERS MUST BE SECURED TO THE STRUCTURAL PURLINS — MINIMUM ONE INCH PENETRATION PAST THE THICKNESS OF STRUCTURAL PURLINS.
2. MEMBRANE SEAMS (SIDE LAPS AND END LAPS) SHALL BE IN SHINGLED FASHION.

OPTION A: WIDE FIELD SHEETS (10' OR 12' WIDE)

100 MPH OR LESS WIND ZONES  
WIDE SHEETS WITH SEAMS OVER PURLINS  
SYSTEMS:  
METAL RETROFIT  
TPO MECHANICALLY FASTENED

DETAIL NO.:  
**MMRT-311**

**MULE-HIDE**  
**PRODUCTS CO., INC.**  
**2011**





**National Support Center • 1195 Prince Hall Drive • Beloit, WI 53511**

©2017 • Printed in USA • MH LIT# SP:PGTPO • Rev. 0 6/17